

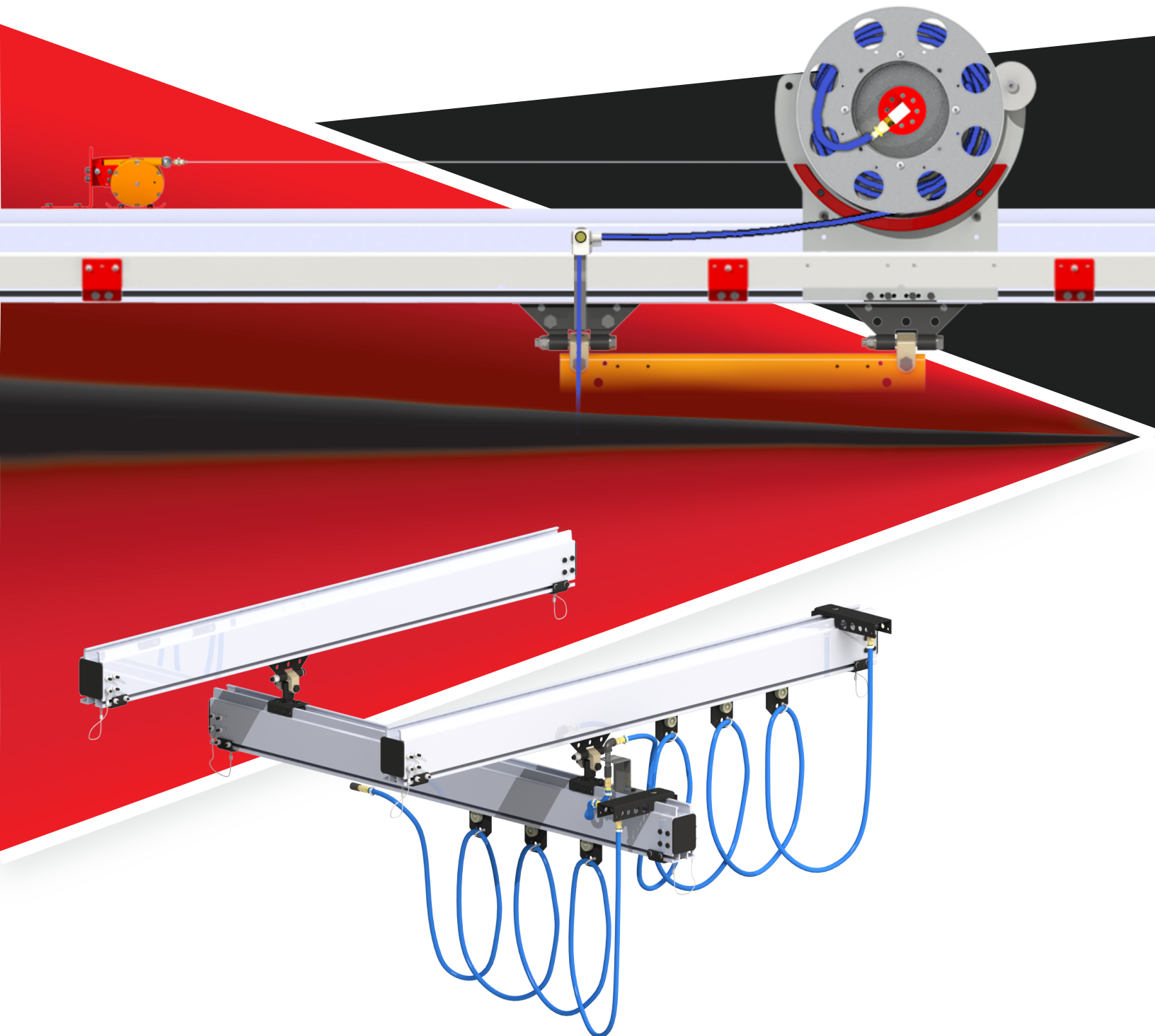

KNIGHT

GLOBAL



Hose Management

rev.20241025

Introduction

Overview	1
--------------------	---

Hose Management

Air Glide Hose Management	2
Jib Crane Hose Management	6
Accessories	7

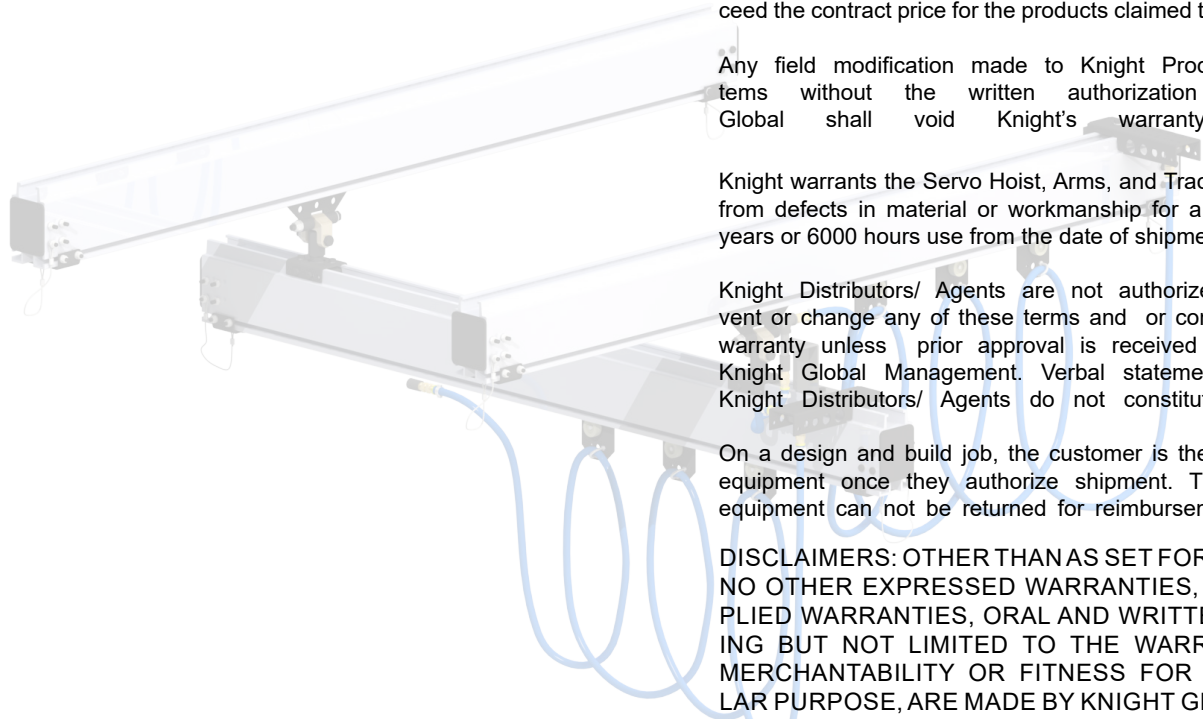

Knight Global | Warranty Information

Knight warrants that its products and parts shall meet all applicable specifications, performance requirements, and be free from defects in material and workmanship for one year, (Servo Systems for two years, Pneumatic Lift Tables for 5 years), from the date of invoice, unless otherwise noted. One exclusion would include any purchased components not manufactured by Knight and their specific individual warranties. Paint defects, scratches and marring from shipping are also excluded.

This warranty shall not cover the failure or defective operation caused by inadequate training provided by customer regarding the operation and / or maintenance of the tool, misuse, negligence, misadjustment, or any alteration not approved by Knight. Knight's obligation is limited to the replacement or repair of Knight's products at a location designated by Knight. Buyer is responsible for all associated internal removal and reinstallation costs as well as freight charges to and from Knight Industries. Knight's maximum liability shall not in any case exceed the contract price for the products claimed to be defective.

Any field modification made to Knight Products or Systems without the written authorization by Knight Global shall void Knight's warranty obligation.

Knight warrants the Servo Hoist, Arms, and Tractors to be free from defects in material or workmanship for a period of two years or 6000 hours use from the date of shipment.

Knight Distributors/ Agents are not authorized to circumvent or change any of these terms and or conditions of this warranty unless prior approval is received in writing by Knight Global Management. Verbal statements made by Knight Distributors/ Agents do not constitute warranties.

On a design and build job, the customer is the owner of the equipment once they authorize shipment. The purchased equipment can not be returned for reimbursement or credit.

DISCLAIMERS: OTHER THAN AS SET FORTH HEREIN, NO OTHER EXPRESSED WARRANTIES, AND NO IMPLIED WARRANTIES, ORAL AND WRITTEN, INCLUDING BUT NOT LIMITED TO THE WARRANTIES OF MERCHANTABILITY OR FITNESS FOR A PARTICULAR PURPOSE, ARE MADE BY KNIGHT GLOBAL WITH RESPECT TO ITS PRODUCTS AND ALL SUCH WARRANTIES ARE HEREBY SPECIFICALLY DISCLAIMED.

KNIGHT GLOBAL SHALL NOT BE LIABLE UNDER ANY CIRCUMSTANCES FOR ANY INCIDENTAL, SPECIAL AND/OR CONSEQUENTIAL DAMAGES WHATSOEVER, WHETHER OR NOT FORESEEABLE, INCLUDING BUT NOT LIMITED TO DAMAGES FOR LOST PROFITS AND ALL SUCH INCIDENTAL, SPECIAL AND/OR CONSEQUENTIAL DAMAGES ARE HEREBY ALSO SPECIFICALLY DISCLAIMED.

KNIGHT GLOBAL WILL NOT BE LIABLE FOR ANY LOSS, INJURY OR DAMAGE TO PERSONS OR PROPERTY, NOR FOR DAMAGES OF ANY KIND RESULTING FROM FAILURE OR DEFECTIVE OPERATION OF ANY MATERIALS OR EQUIPMENT FURNISHED HEREUNDER.

We are committed to
Total Customer Satisfaction
through
QUALITY, RELIABILITY and
EMPLOYEE INVOLVEMENT.

Overview

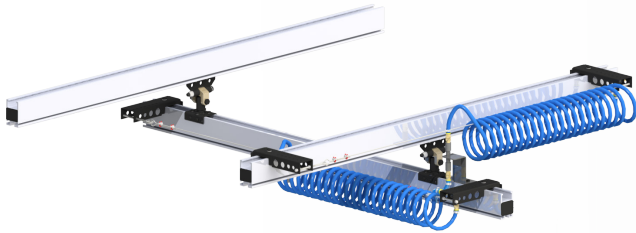

Knight Global's Hose Management provides everything you will need to quickly and efficiently run your pneumatic supply system. Knight offers kits for straight or coiled hose system requirements, as well as kits for runways or bridges.

Knight also has kits available for Jib Crane's hose management as well as the new patent pending product, the AIR GLIDE.

For more information on Knight Hose Management or if you need help in selecting the proper kit for your system; contact a Knight representative.

Features

- Attaches to RAD4110, RAD6110 & RAD7510 Series Rail.
- Supplies Air to Tooling.

Options

- Coiled Hose for Bridges or Runways
- Straight Hose for Bridges or Runways
- Air Glide Hose Management
- Jib Crane Hose Management

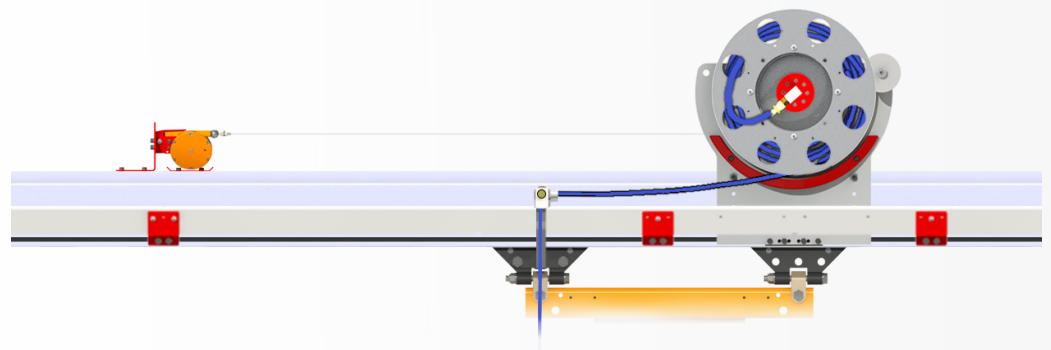
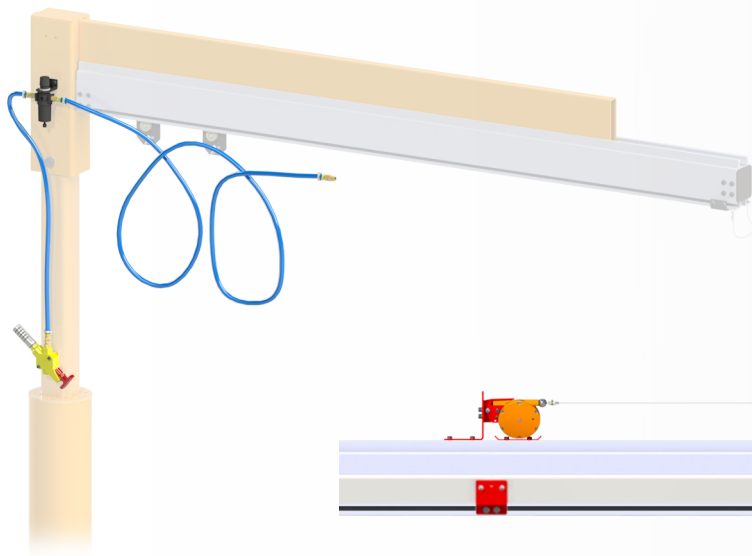

Enclosed Rail Hose Mgmt.

MRMS4308 / MRMS4309 Coiled Hose Management Kits

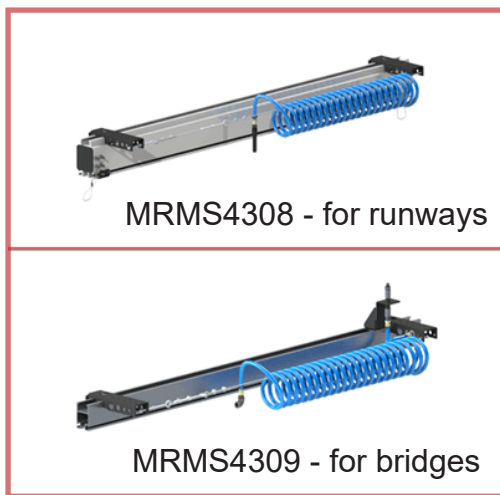

MRMS4310 / MRMS4311 Straight Hose Management Kits

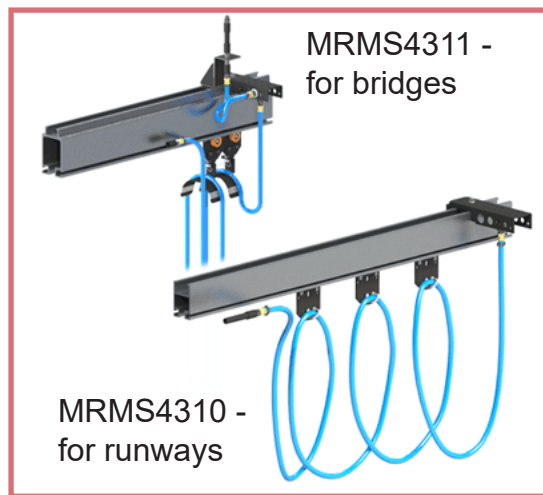

Features

- Attaches to RAD4110, RAD6110 & RAD7510 Series Rail.
- Supplies Air to Tooling.
- Festoon Kit includes:
 - Brackets, Fittings and Messenger Cable for (1) one Runway OR (1) Bridge.
- Hose Fitting Diameters: **1/2 in. [12.7mm]**.
- Hose and regulator can be purchased separately.
- Hose Trolleys Sold Separately.

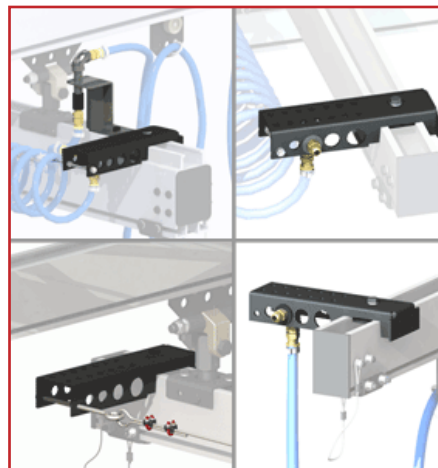

Air Glide Hose Management

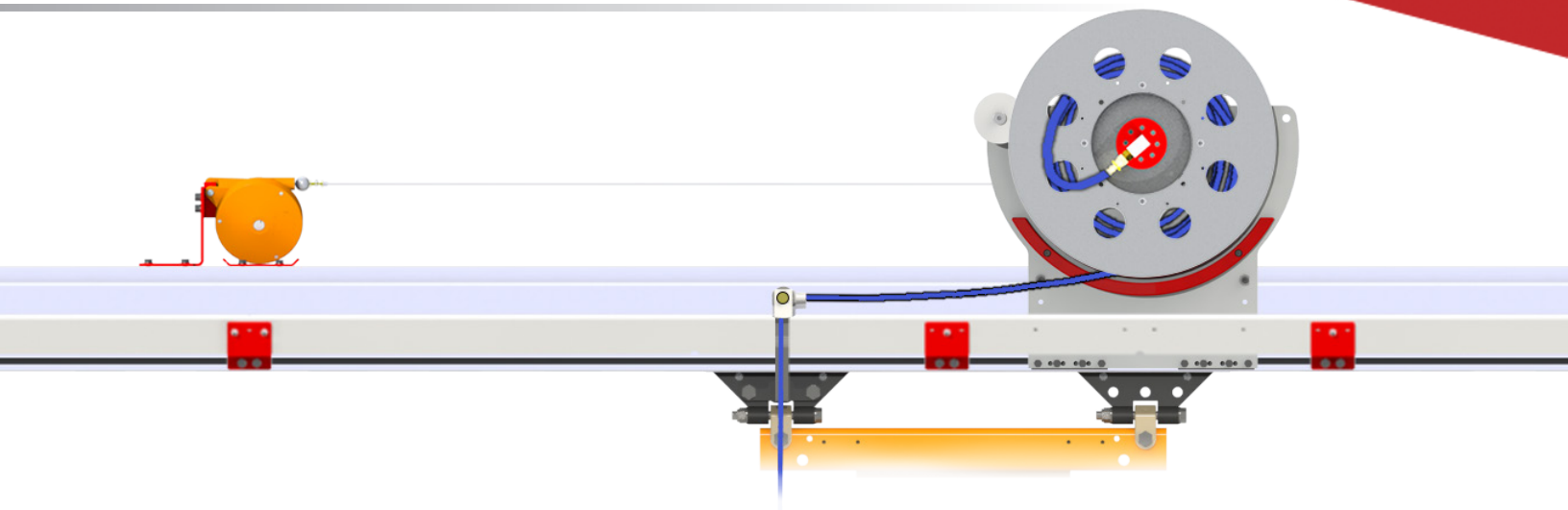

MRMSC/MRMSE Air Glide Hose Management

This new patent pending hose management system is a revolutionary solution to containing air hoses on the rail itself instead of hanging below. Using a reel and a channel that mounts alongside the rail, air hoses can be kept out of the way and are prevented from interfering with production in a plant setting. This exciting new product can also be integrated into existing systems.

Features

- Designed to eliminate the need for hanging air hoses / festooning.
- Supplies Air to Tooling.
- Attaches to RAD4110, RAD6110 and RAD7510 series rail.
- Reel can be mounted in the center or end of rail.
- Can be attached to any bridge and/or runway.
- Max rail length: **100 ft. [30.48m]**.
- Rail not included.



Benefits

- Can be used with zone limits, end-of-travel switches, and rail brakes.
- Has a significant advantage over coiled hose because it minimizes pullback force.
- Custom mounting options are available for low profile trolleys and other manufacturers' rail.

Air Glide Hose Mgmt. (Cont...)

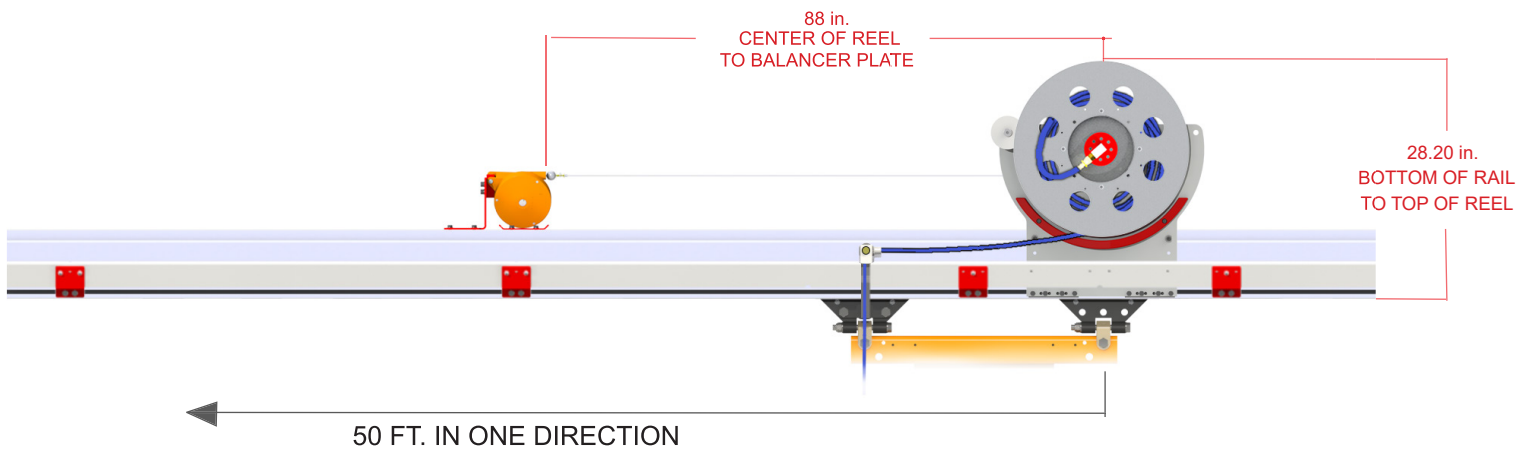
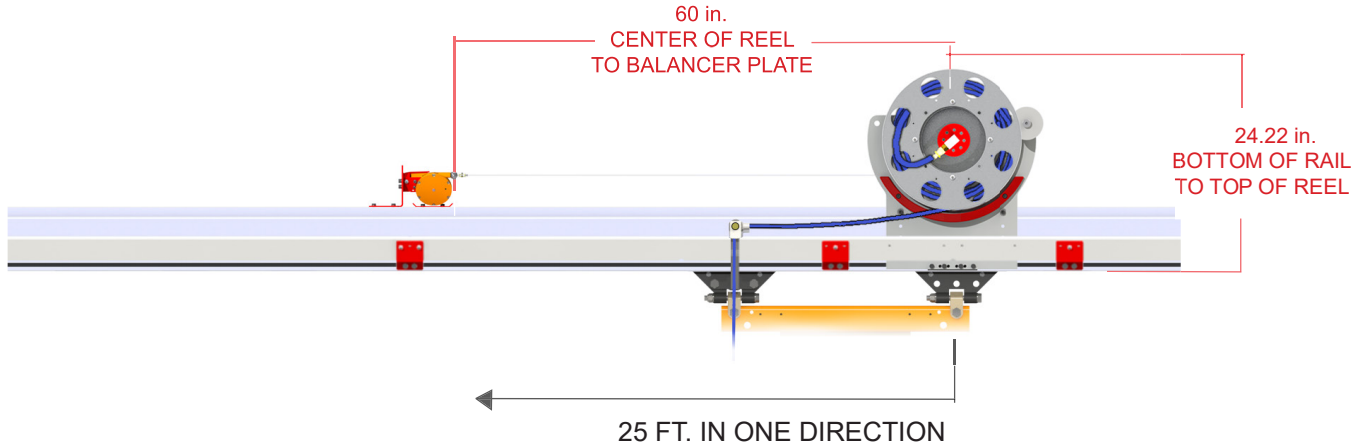

AIR GLIDE FOR END OF RAIL		
Air Glide Type	Reel Position	Hose Travel Length (ft.)
MRMSS	E	010
MRMSS	E	020
MRMSS	E	025
MRMSL	E	030
MRMSL	E	040
MRMSL	E	050

MRMSSE / MRMSLE

Air Glide for End of Rail Applications

- When mounted at the end of rail, Air Glide hose can travel up to 50 ft. in one direction.
- Small size reel hose can travel up to 25 ft.
- Large size reel hose can travel up to 50 ft.

Note: Standard hangers can be used if the Air Glide will be mounted perpendicular to I-Beam. Custom hangers must be used if Air Glide is mounted parallel to I-Beam.

Air Glide Hose Mgmt. (Cont...)

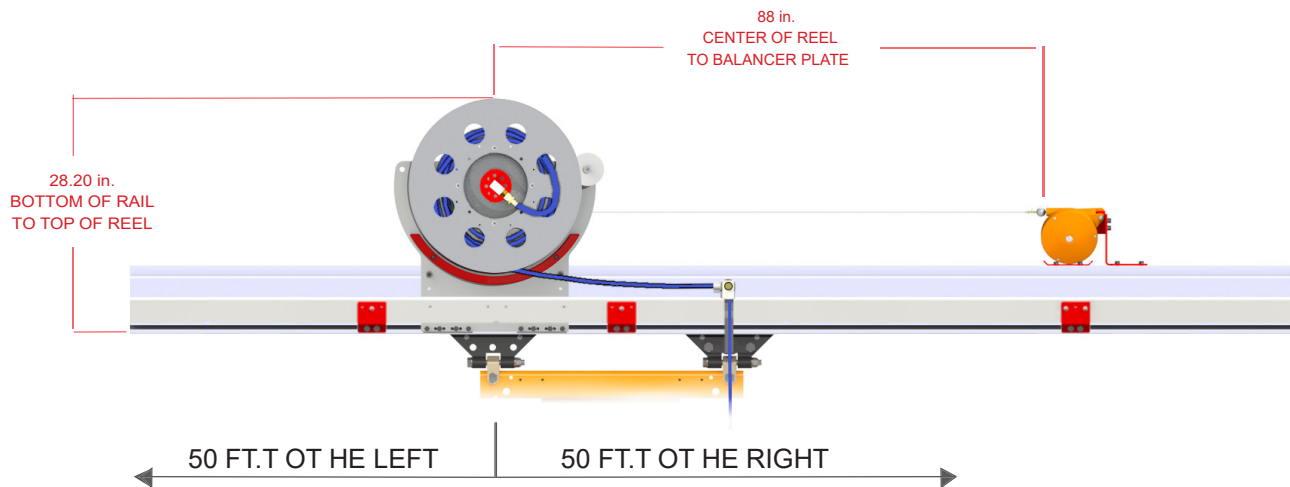
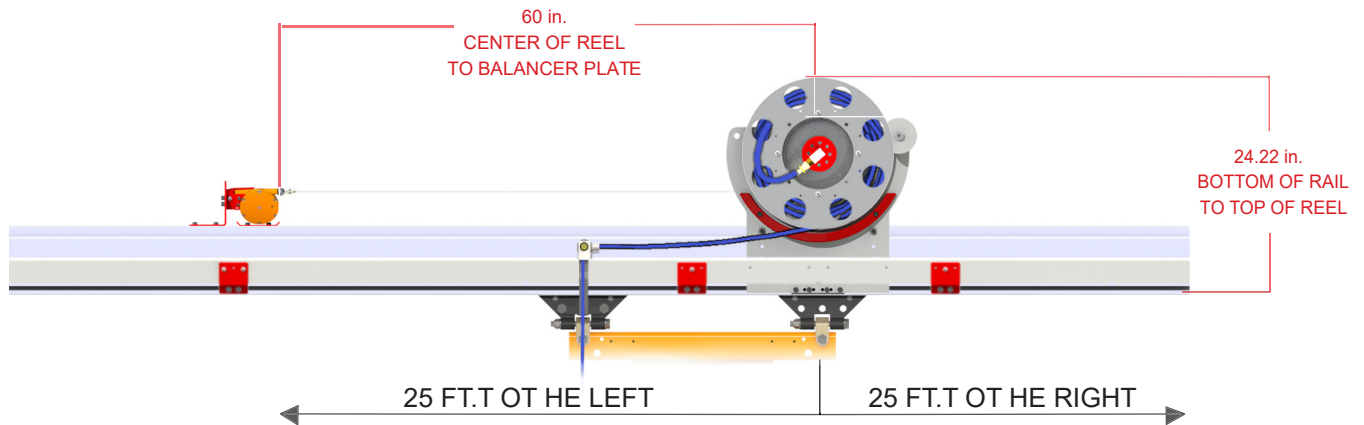

AIR GLIDE FOR CENTER OF RAIL		
Air Glide Type	Reel Position	Hose Travel Length (ft.)
MRMSS	C	010
MRMSS	C	020
MRMSS	C	030
MRMSS	C	040
MRMSS	C	050
MRMSL	C	060
MRMSL	C	070
MRMSL	C	080
MRMSL	C	090
MRMSL	C	100

MRMSSC / MRMSLC

Air Glide for Center of Rail Applications

- When mounted at the end of rail, Air Glide hose can travel up to 50 ft. in one direction.
- Small size reel hose can travel up to 25 ft. in both directions.
- Large size reel hose can travel up to 50 ft. in both directions.

Jib Crane Hose Management

JSA9135 / JSA9140

Coiled Hose Kit / Straight Hose Kit

Knight Global's Jib Crane Hose Management will attach to MJBA2100, MJBA2200, MJBA2300 and MJBA2600 Series Jib Cranes. The kits supply air to Tooling and End Effectors. It includes: all brackets, fittings, regulator, air lock-out and messenger cable for (1) one Jib Crane.

Features

- Attaches to Knight MJBA2100, MJBA2200, MJBA2300 and MJBA2600 Jib Cranes.
- Supplies Air to Tooling.
- Festoon Kit includes:
 - Brackets, Fittings, Regulator, Air Lock-out and Messenger Cable for (1) one Jib Crane.
- Hose Fitting Diameters: 1/2 in. [12.7mm].

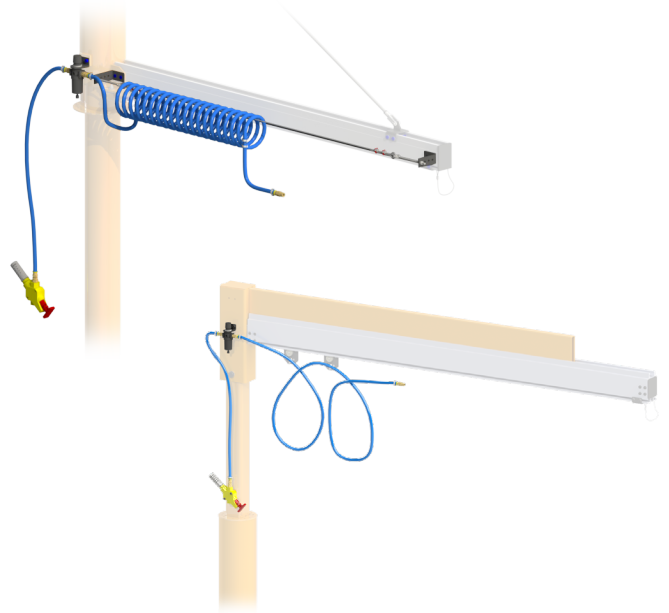

MJSAE2200 / MJSAE2300 Air Glide Hose Management



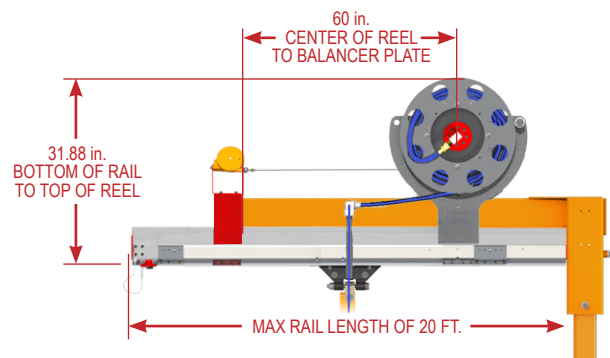
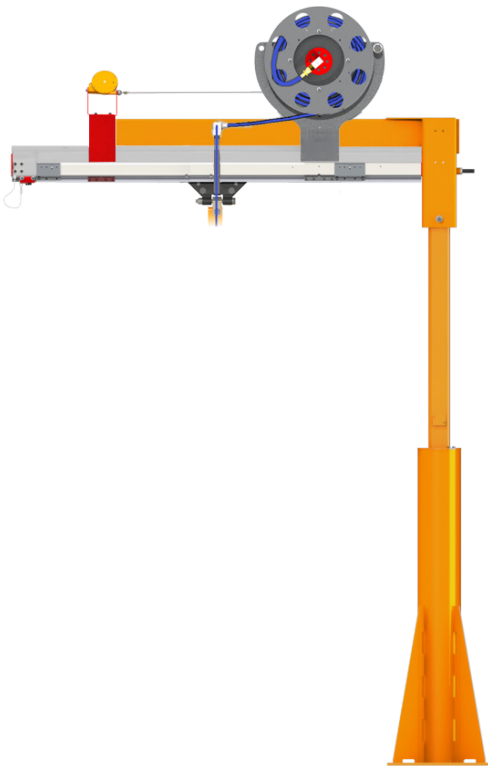

Features

- MJSAE2200 Attaches to Knight MJBA2200 Jib Cranes.
- MJSAE2300 attaches to Knight MJBA2300, 2600 and 2700 Jib Cranes.
- Max rail length of 20 ft.
- Supplies Air to Tooling.
- Hose Fitting Diameters: 1/2 in. [12.7mm].

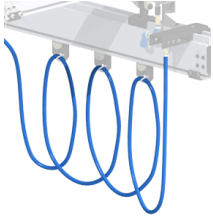
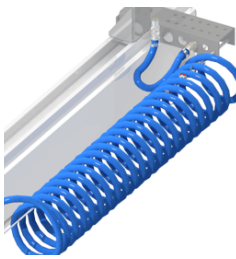

For more information on Knight's Jib Crane Hose Management Kit and Accessories, or if you need help in selecting the proper accessory for your system; contact a Knight representative or please visit www.knightglobal.com

Accessories

RMD4113 1/2 in. Diameter Straight Hose	RMD4115 1/2 in. Diameter Coiled Hose	JSA9137 360° Rotate Air Fitting Assembly	MRMA4488 Filter/Regulator Bracket Assembly	TRM2088 Filter/Regulator Bracket Assembly
 <p>1/2 in. I.D. Polyurethane Straight Hose is used in conjunction with the rail system hose management kits to create the systems festooning.</p>	 <p>1/2 in. I.D. Polyurethane Coiled Hose is used in conjunction with the rail system hose management kits to create the systems festooning.</p>	 <p>Rotating Air Fitting will attach festooning to Knight's Jib Cranes Series. Air Fitting kit supplies air to Tooling and End Effectors.</p>	 <ul style="list-style-type: none"> • Controls air flow to the work station crane. • NPT Filter and Regulator: 1/2 in. [12.7mm]. • (FOR RAD series Rail) 	 <ul style="list-style-type: none"> • Attaches to TR2000 Series Rail. • Controls air flow to the workstation crane. • Primarily used in Knight's Hose Management Kits.

MRMA6115 Hose Trolley with Cable Saddle	MRMA4301 Cabbble Saddle with Velcro Straps	MRMA6114 Straight Hose Trolley	MRMA4494 Messenger Cable Hose Trolley
 <ul style="list-style-type: none"> • Carries festooned hose or cable used in hose management kits. • Velcro straps secures hose. • Max. Capacity: Up to 50 lbs. [22kg]. 	 <ul style="list-style-type: none"> • Attaches to Load Trolleys. • Steel Construction. • Pivoting Joint. • Supports up to: 2 in. [51mm] Electric Cable or Pneumatic Hose. 	 <ul style="list-style-type: none"> • Carries festooned hose used in hose management kits. • Max. Capacity: Up to 50 lbs. [22kg]. 	 <ul style="list-style-type: none"> • Travels on a tag line on the side of the rail system and uses the complete length of the rail. • Carries festooned hose or cable used in hose management kits. • Zero stack-up lengths.

For more information on Knight's Hose Management Kit Accessories or if you need help in selecting the proper accessory for your system; contact a Knight representative.

Shown Hose Management Kit Accessories will not cover all of Knight's Aluminum or Jib Crane Rail Systems. For a full list of accessories and hose management kit product descriptions, please visit www.knightglobal.com.