



KNIGHT

GLOBAL



Pneumatic and Servo Arms Series

rev.20240925

Introduction

Overview	1
--------------------	---

Pneumatic Arm Series

AAA4000 Series	2
AAA4000 Pedestal Series	4
AAA4000 Linear Rail Series	6
AAA6000 Overhead Series	8
AAA6000 Pedestal Series	10
AAA9000 Overhead Series	12
AAA9000 Pedestal Series	14
ATA4000 Series	16
Pneumatic Accesories	17
KEAA2000 Dual Bridge Extension Arm Series	18
KEAA2500 Single Bridge Extension Arm Series	20
KEAA Arm Accesories.	22
KSHCA Series	23
KSHFA Series	24
KSHEA Series.	25
KSHAEA Series.	26
KSHEB Series.	27
KSHAEB Series.	28
KSHVA Series.	29
KSHVAA Series.	30
Servo Arm Accesories.	31
Servo Arm Controls.	33

Knight Global | Warranty Information

Knight warrants that its products and parts shall meet all applicable specifications, performance requirements, and be free from defects in material and workmanship for one year, (Servo Systems for two years, Pneumatic Lift Tables for 5 years), from the date of invoice, unless otherwise noted. One exclusion would include any purchased components not manufactured by Knight and their specific individual warranties. Paint defects, scratches and marring from shipping are also excluded.

This warranty shall not cover the failure or defective operation caused by inadequate training provided by customer regarding the operation and / or maintenance of the tool, misuse, negligence, misadjustment, or any alteration not approved by Knight. Knight's obligation is limited to the replacement or repair of Knight's products at a location designated by Knight. Buyer is responsible for all associated internal removal and reinstallation costs as well as freight charges to and from Knight Industries. Knight's maximum liability shall not in any case exceed the contract price for the products claimed to be defective.

Any field modification made to Knight Products or Systems without the written authorization by Knight Global shall void Knight's warranty obligation.

Knight warrants the Servo Hoist, Arms, and Tractors to be free from defects in material or workmanship for a period of two years or 6000 hours use from the date of shipment.

Knight Distributors/ Agents are not authorized to circumvent or change any of these terms and or conditions of this warranty unless prior approval is received in writing by Knight Global Management. Verbal statements made by Knight Distributors/ Agents do not constitute warranties.

On a design and build job, the customer is the owner of the equipment once they authorize shipment. The purchased equipment can not be returned for reimbursement or credit.

DISCLAIMERS: OTHER THAN AS SET FORTH HEREIN, NO OTHER EXPRESSED WARRANTIES, AND NO IMPLIED WARRANTIES, ORAL AND WRITTEN, INCLUDING BUT NOT LIMITED TO THE WARRANTIES OF MERCHANTABILITY OR FITNESS FOR A PARTICULAR PURPOSE, ARE MADE BY KNIGHT GLOBAL WITH RESPECT TO ITS PRODUCTS AND ALL SUCH WARRANTIES ARE HEREBY SPECIFICALLY DISCLAIMED.

KNIGHT GLOBAL SHALL NOT BE LIABLE UNDER ANY CIRCUMSTANCES FOR ANY INCIDENTAL, SPECIAL AND/OR CONSEQUENTIAL DAMAGES WHATSOEVER, WHETHER OR NOT FORESEEABLE, INCLUDING BUT NOT LIMITED TO DAMAGES FOR LOST PROFITS AND ALL SUCH INCIDENTAL, SPECIAL AND/OR CONSEQUENTIAL DAMAGES ARE HEREBY ALSO SPECIFICALLY DISCLAIMED.

KNIGHT GLOBAL WILL NOT BE LIABLE FOR ANY LOSS, INJURY OR DAMAGE TO PERSONS OR PROPERTY, NOR FOR DAMAGES OF ANY KIND RESULTING FROM FAILURE OR DEFECTIVE OPERATION OF ANY MATERIALS OR EQUIPMENT FURNISHED HEREUNDER.

We are committed to
Total Customer Satisfaction
through
QUALITY, RELIABILITY and
EMPLOYEE INVOLVEMENT.

Overview

Knight Pneumatic Arms

Knight Pneumatic, Extension, Vertical and Servo Arms Series provide a wide variety of configurations to lift, rotate, balance, move and transfer product to and from conveyors, dunnage, assembly lines and much more. Knight arms allow for the positioning of a fixture or end effector within a specified work cell or typical work area using overhead or floor mounted workstation cranes.

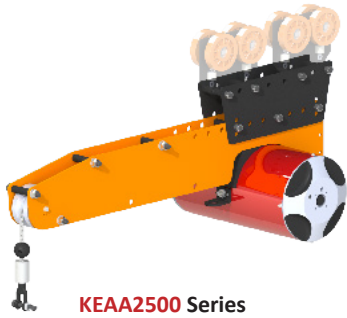

KEAA2500 Series



AAA4000 Series



AAA6000 Series

Pneumatic Arms Series

Knight Pneumatic arms use a parallelogram structure that articulates at the vertical planes. This design allows vertical positioning of a fixture or end effector. Knight Global offers a wide range of arm types, capacities and configurations to handle many types of end tooling.

Pneumatic arms are used to lift, rotate, balance, move and transfer product to and from conveyors, dunnage, assembly lines and more.



AAA4000 Series

Knight AAA4000 Light Duty Articulating Arm

Knight Global's AAA4000 Overhead Mounted Light Duty Articulating Arm is a parallelogram arm that utilizes a single cylinder in the rear of the arm to achieve greater lifting capacity. The AAA4000 travels inside Knight's RAD4110, RAD6110, or RAD7510 Aluminum Series Rail Systems. This Arm is for secure tools and light lifting applications.

The AAA4000 Articulating Arm is used to lift, rotate, balance, and move product from conveyors, dunnage, assembly lines and more. The AAA4000 features a variety of control configurations.

Features

- CE Compliant **
- Travels inside Knight's RAD4110, RAD6110, or RAD7510 Series Rail.
- Variety of Control Configurations.
- Overhead Carriage Sizes:
24 in. [609mm] or 36 in. [914mm].
- Max. Vertical Mast Length:
Up to 9 ft. [2743mm].
- Max. Arm Length: Up to 36 in. [914mm].
- Max. Extension Boom Length:
Up to 36 in. [914mm].
- Max. Vertical Arm Travel:
Up to 36 in. [914mm].
- Max. Lifting/Balance Capacity:
Up to 50 lbs. [23kg] at 60 psi [4.1bar].

**CE compliance is not a standard feature on Knight Global Pneumatic Arms. Please contact us for more details.

Benefits

- Pedestal Mounted or Linear Rail Configurations Available.
- Reduces Operator Fatigue.
- Arm travels on the "X", "Y", and "Z" Axis.
- Absorbs Torque Reaction.
- Fixed or 360° Rotation.
- Optional Pivot Brake.
- Optional Parking Brake.
- Optional Clutch Brake.

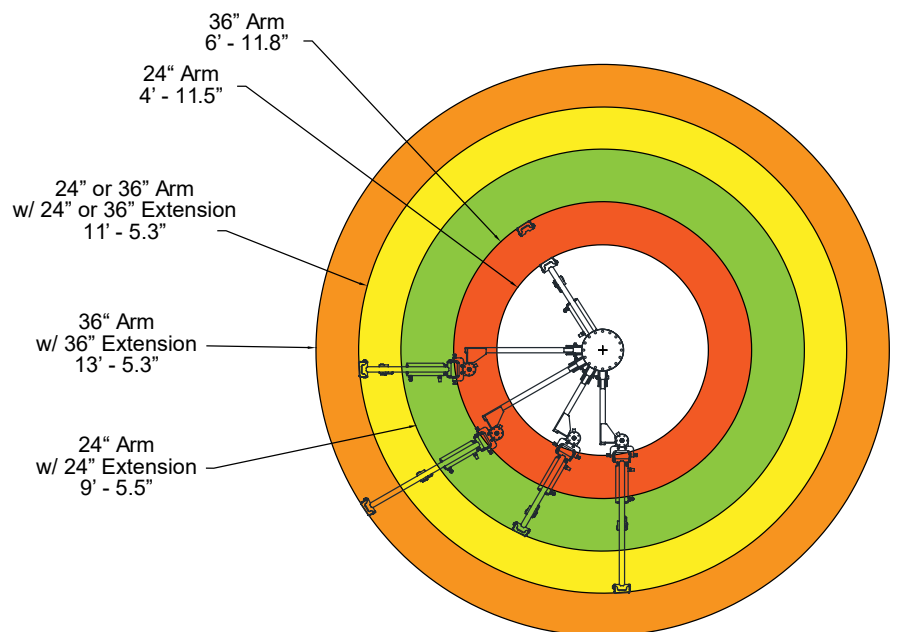

AAA4000 Series

Arm Extensions

Part # AOA4009
Extension Arm (B)
 (2) DISC BRAKES

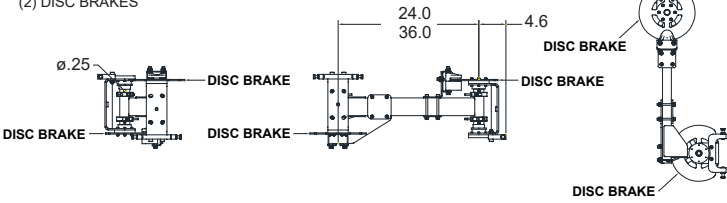

Part # AOA4010
Extension Arm (C)
 (1) DISC BRAKE

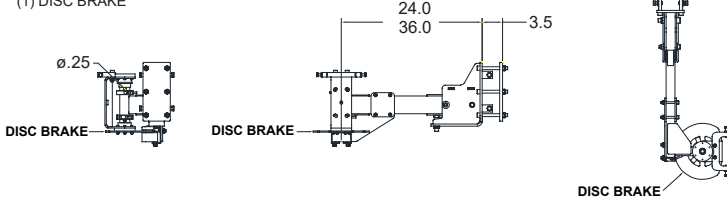

Part # AOA4006
Extension Arm (D)
 (2) CLUTCH BRAKES

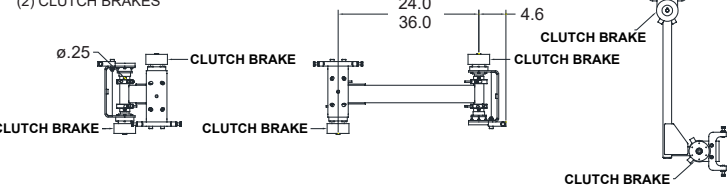

Part # AOA4004
Extension Arm (E)
 (1) CLUTCH BRAKE

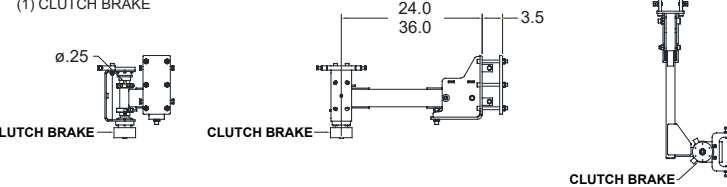

Arm Accessories

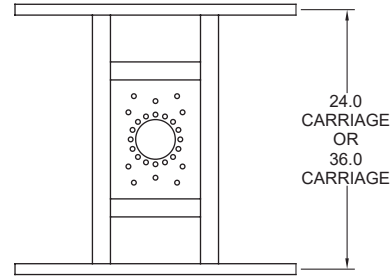

Trolleys

RAD4110
MRTA4009

RAD6110
MRTA6124

RAD7510
MRTA7723

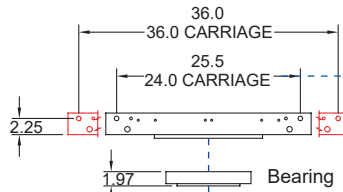

FLAT I-BEAM
ATA2603

S-BEAM
ATA2604

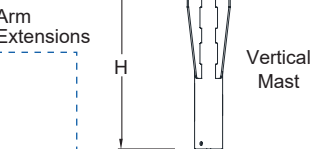

Arm Extensions

Vertical Mast

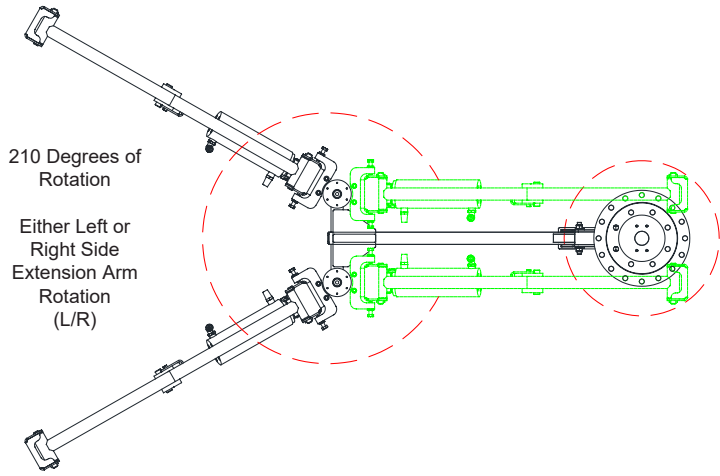
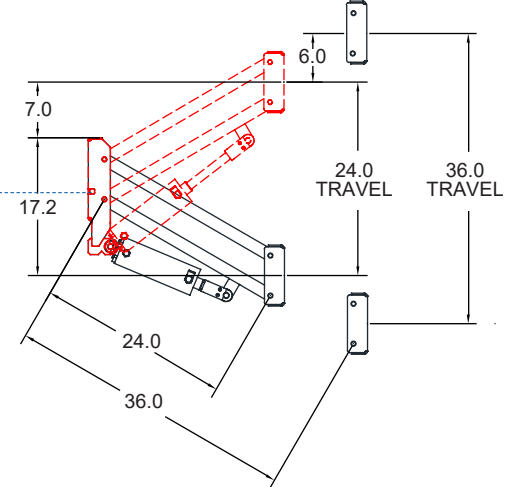
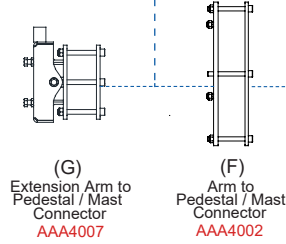

Optional		
Description	Model #	
Knight RAD7510 Air Tractor	TRA5500	
Knight Rail Brake	MRAA4359	

ORDER # EX: 4_24_B24L_F_H99_J_L24

Optional [Omit if not required]						
Arm Desc.	Arm Length	Arm Extension	Connector	Mast	Bearing	Carriage
4X	X	XXX	X	XXX	X	XXX
	24 36	B24L, B24R B36L, B36R C24L, C24R C36L, C36R D24L, D24R D36L, D36R E24L, E24R E36L, E36R	F = AAA4002 G = AAA4007	Specify Length (Inches) HXX	J = yes K = no	L24 L36
ARM			ARM ACCESSORIES			

AAA4000 Series



Knight AAA4000 Light Duty Pedestal Mounted Articulating Arm

Knight Global's AAA4000 Pedestal Mounted Light Duty Articulating Arm is a parallelogram arm that utilizes a single cylinder in the rear of the arm to achieve greater lifting capacity. This Arm is for secure tools and light lifting applications.

The AAA4000 Articulating Arm is used to lift, rotate, balance, and move product from conveyors, dunnage, assembly lines and more.

Knight offers fixed and rotational arm configurations.

Features

- CE Compliant **
- Pedestal Mounted.
- Adjustable Arm Heights.
- Variety of Control Configurations.
- Max. Pedestal Height:
Up to 6 ft. [1828mm]. *
- Max. Arm Length: Up to 36 in. [914mm].
- Max. Extension Boom Length:
Up to 36 in. [914mm].
- Max. Vertical Arm Travel:
Up to 36 in. [914mm].
- Max. Lifting/Balance Capacity:
Up to 50 lbs. [23kg] at 60 psi [4.1bar].

**CE compliance is not a standard feature on Knight Global Pneumatic Arms. Please contact us for more details.

* Custom posts can be ordered for applications over 6ft.

Benefits

- Overhead Mounted or Linear Rail Configurations Available.
- Reduces Operator Fatigue.
- Arm travels on the "X", "Y", and "Z" Axis.
- Absorbs Torque Reaction.
- Fixed or Rotational.
- Optional Pivot Brake.
- Optional Parking Brake.
- Optional Clutch Brake.

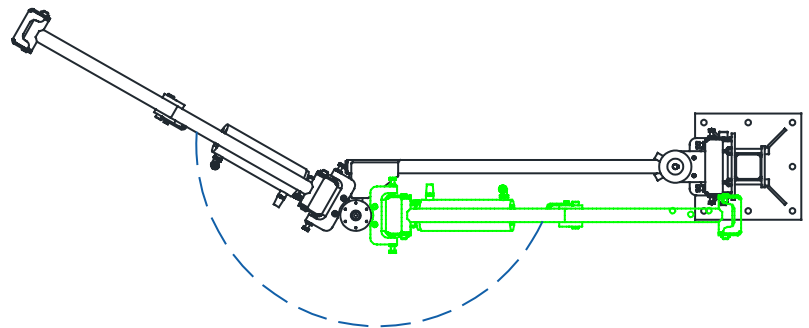

210 Degrees of
Rotation

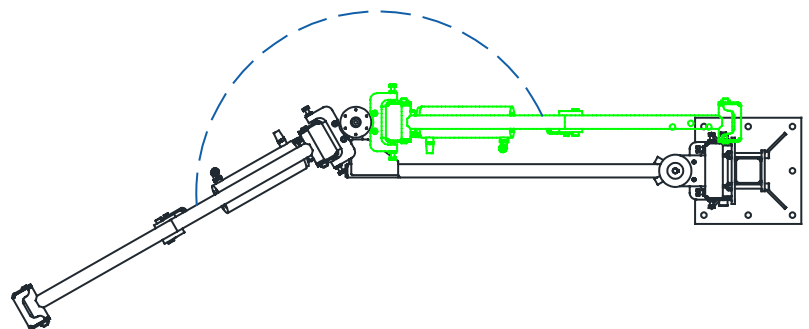

AAA4000 Series

Arm Extensions

Part # AOA4009

Extension Arm (B)
(2) DISC BRAKES

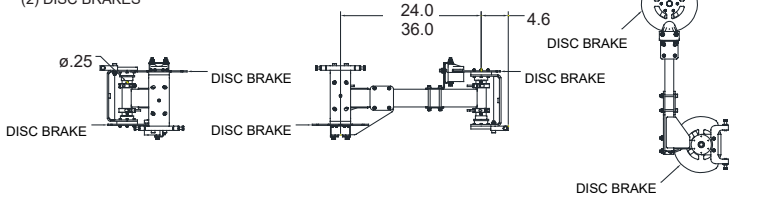

Part # AOA4010

Extension Arm (C)
(1) DISC BRAKE

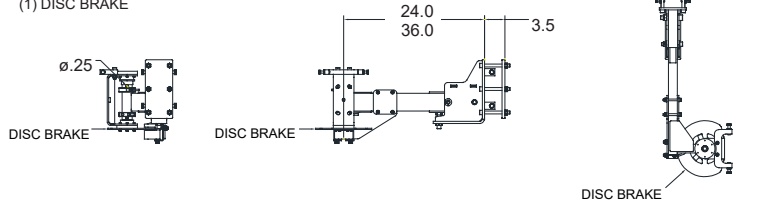

Part # AOA4006

Extension Arm (D)
(2) CLUTCH BRAKES

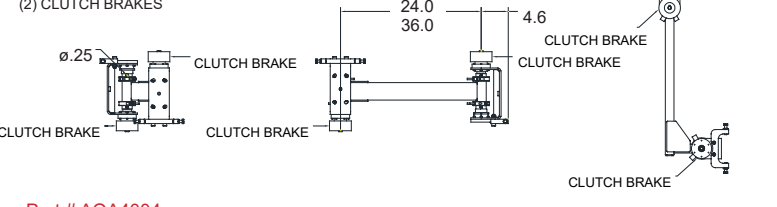

Part # AOA4004

Extension Arm (E)
(1) CLUTCH BRAKE

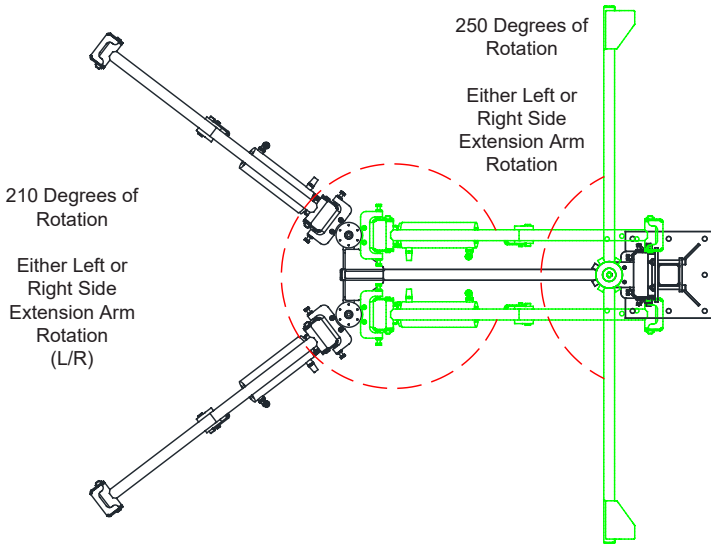
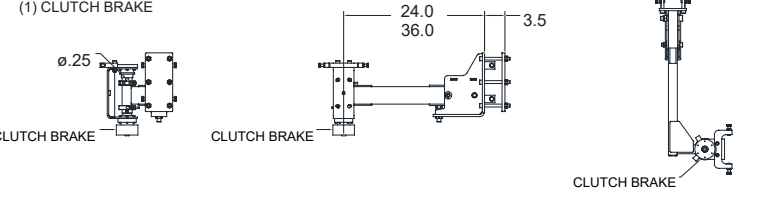

Arm Configurations

(G)
Extension Arm to
Pedestal Connector
AAA4007

(F)
Arm to Pedestal
Connector
AAA4003

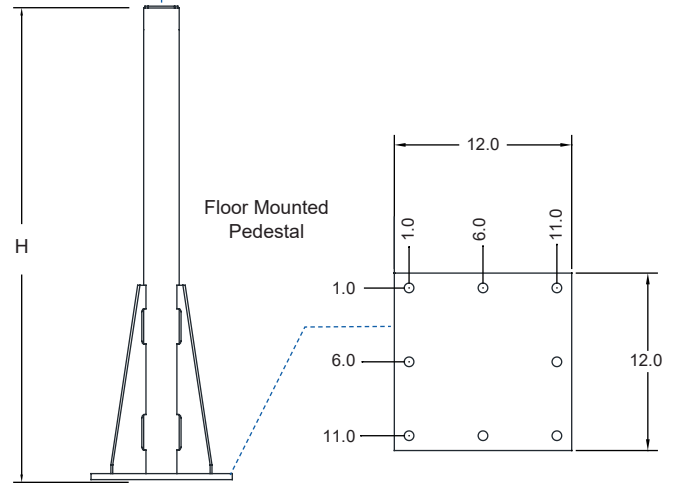
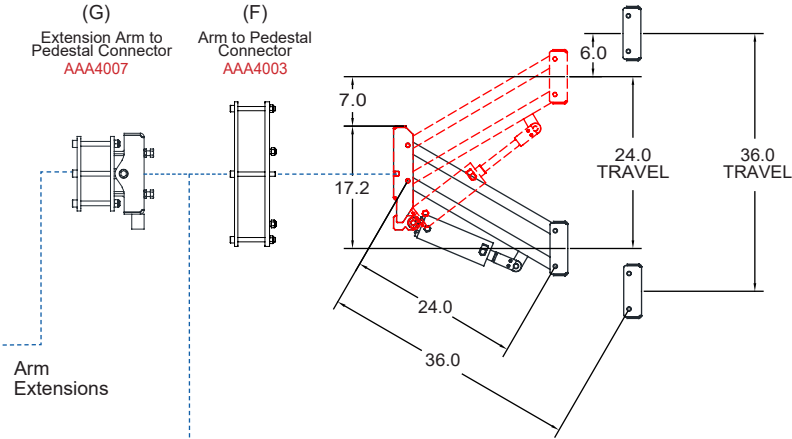

ORDER # EX: P4_24_B24L_F_H72

Optional [Omit if not required]

Arm Desc.	Arm Length	Arm Extension	Connector	Pedestal Height
P4	XX	XXX	X	XXX
	24 36	B24L, B24R B36L, B36R C24L, C24R C36L, C36R D24L, D24R D36L, D36R E24L, E24R E36L, E36R	F = AAA4003 G = AAA4007	Specify Height (Inches) HXX
ARM		ARM ACCESSORIES		

AAA4000 Series

Knight AAA4000 Light Duty Linear Rail Articulating Arm

Knight Global's AAA4000 Linear Rail Mounted Light Duty Articulating Arm is a parallelogram arm that utilizes a single cylinder in the rear of the arm to achieve greater lifting capacity. This Arm is for secure tools and light lifting applications.

The AAA4000 Arm is used to lift, rotate, balance, and move product from conveyors, dunnage, assembly lines and more. The AAA4000 features a variety of control configurations.

Knight offers fixed and rotational arm configurations.

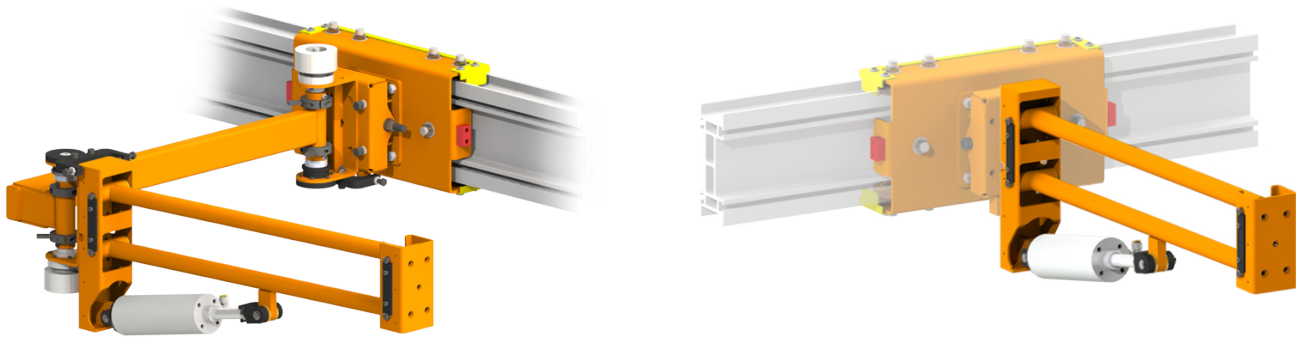

Features

- CE Compliant **
- Linear Rail Pedestal or Wall Mounted.
- Variety of Control Configurations.
- Max. Arm Length: Up to 36 in. [914mm].
- Max. Extension Boom Length: Up to 36 in. [914mm].
- Max. Vertical Arm Travel: Up to 36 in. [914mm].
- Max. Lifting/Balance Capacity: Up to 50 lbs. [23kg] at 60 psi [4.1bar].

**CE compliance is not a standard feature on Knight Global Pneumatic Arms. Please contact us for more details.

Benefits

- Pedestal Mounted or Overhead Configurations Available.
- Reduces Operator Fatigue.
- Arm travels on the "X", "Y", and "Z" Axis.
- Absorbs Torque Reaction.
- Fixed or Rotational.
- Optional Pivot Brake.
- Optional Parking Brake.
- Optional Clutch Brake.

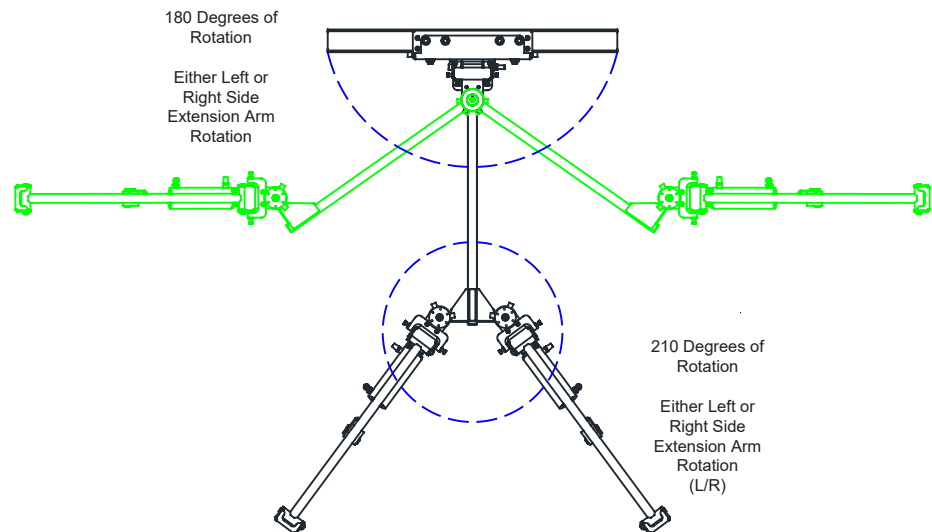

AAA4000 Series

Arm Extensions

Part # AOA4009

Extension Arm (B)

(2) DISC BRAKES

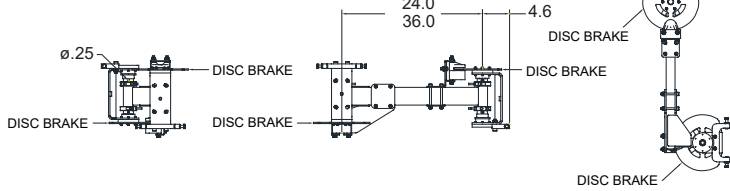

Part # AOA4010

Extension Arm (C)

(1) DISC BRAKE

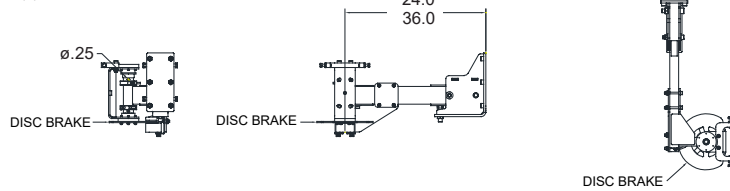

Part # AOA4006

Extension Arm (D)

(2) CLUTCH BRAKES

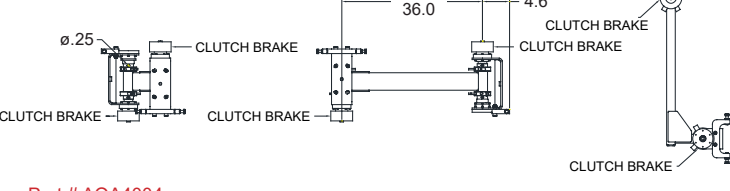

Part # AOA4004

Extension Arm (E)

(1) CLUTCH BRAKE

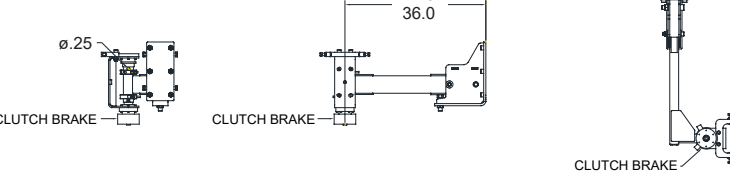

Arm Accessories

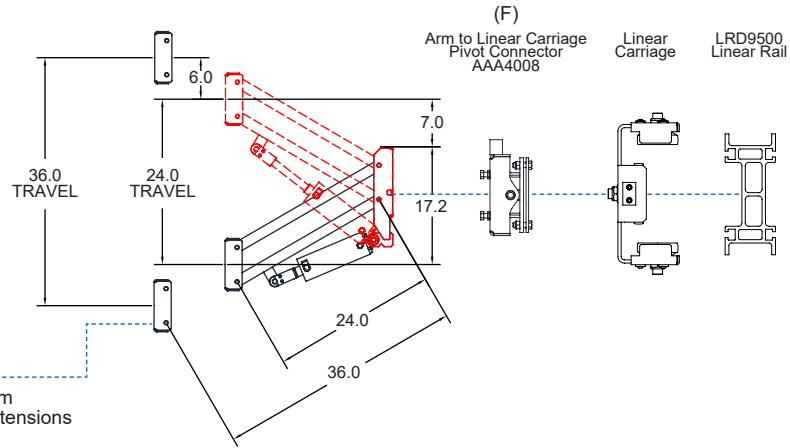

ORDER # EX: L4_24_B24L_F

Arm Desc.	Arm Length	Optional [Omit if not required]	
		Arm Extension	Connector
L4	XX	XXX	X
	24 36	B24L, B24R B36L, B36R C24L, C24R C36L, C36R D24L, D24R D36L, D36R E24L, E24R E36L, E36R	F = AAA4008
ARM		ARM ACCESSORIES	

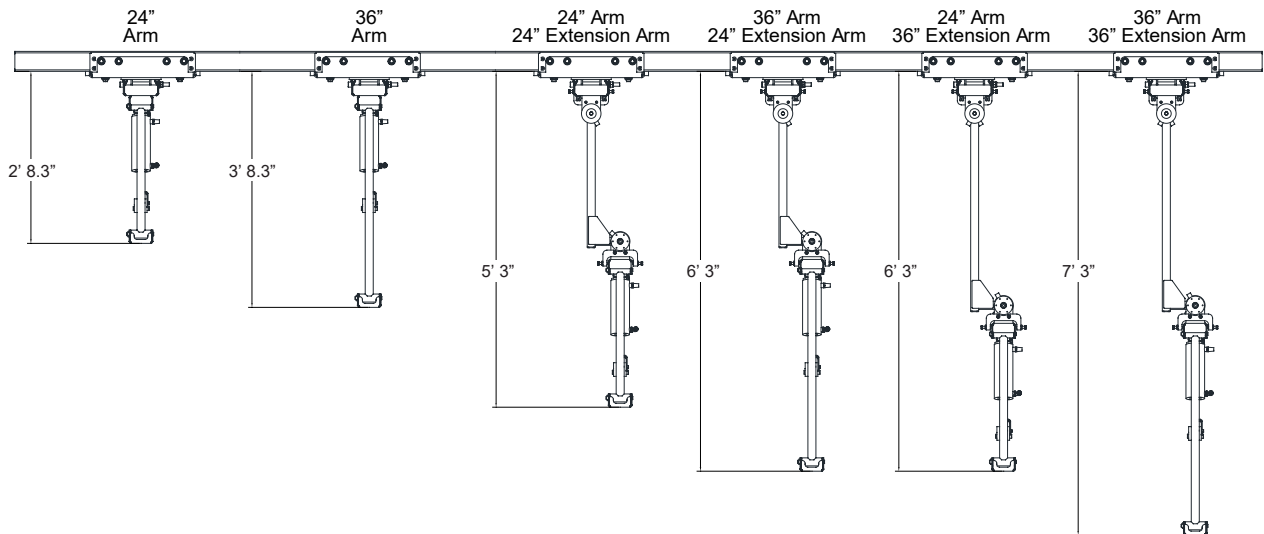

Knight AAA6000 Medium Duty Low Profile Arm



Knight's Overhead Mounted AAA6000 travels inside Knight's RAD4110, RAD6110, or RAD7510 Aluminum Series Rail Systems. Knight's AAA6000 Medium Duty Arm reduces fatigue by absorbing torque reaction and lifting/manipulating product effortlessly for the operator. The AAA6000 Articulating Arm is used to lift, rotate, balance, and move product from conveyors, dunnage, assembly lines and more. Knight's AAA6000 travels on the "X", "Y", and "Z" axis and features a variety of control configurations.

Knight offers fixed and 360 degree rotational AAA6000 Articulating Arms. Knight Global's AAA6000 Articulating Arm has a maximum reach (without Extension Boom) of 48 in. [1,219mm] and a maximum lifting/balance capacity of up to 430 lbs. [195kg] at 100 psi [6.8bar]. Capacities vary with reach; for more information contact a Knight Global representative.

Features

- CE Compliant **
- Travels inside Knight's RAD4110, RAD6110, or RAD7510 Series Rail.
- Lifts, Rotates, Balances, and Manipulates product with minimal effort.
- Variety of Control Configurations.
- Overhead Carriage Sizes: 24 in. [609mm] or 36 in. [914mm].
- Max. Arm Length: Up to 48 in. [1,219mm].
- Max. Extension Boom Length: Up to 48in. [1,219mm] (Lengths over 48 in. Contact a Knight Representative).
- Max. Vertical Arm Travel: Up to 48 in. [1,219mm].

**CE compliance is not a standard feature on Knight Global Pneumatic Arms. Please contact us for more details.

Benefits

- Pedestal Mounted Configuration Available.
- Reduces Operator Fatigue.
- Arm travels on the "X", "Y", and "Z" Axis.
- Absorbs Torque Reaction.
- Fixed or 360° Rotation.
- Optional Pivot Brake.
- Optional Parking Brake.
- Optional Clutch Brake.

Arm capacity is reduced by weight of arm extension

Arm Lifting Capacity			
Reach	60 P.S.I.	80 P.S.I.	100 P.S.I.
24 in. 609mm	240 lbs. 108kg	325 lbs. 147kg	430 lbs. 195kg
36 in. 914mm	190 lbs. 86kg	265 lbs. 120kg	335 lbs. 152kg
48 in. 1219mm	100 lbs. 45kg	185 lbs. 84kg	250 lbs. 113kg

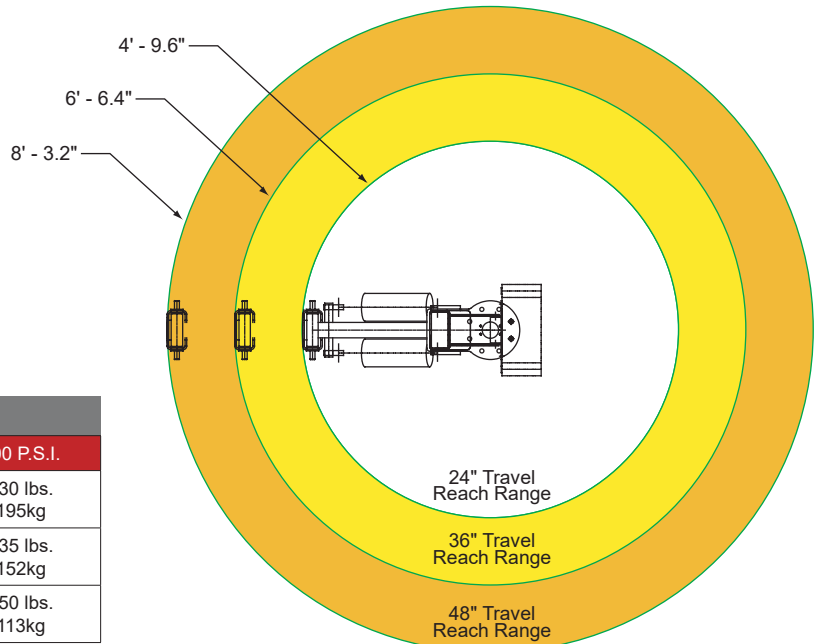

AAA6000 Series

Arm Extensions

Part # AOA6005
Extension Arm (B)

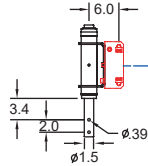

Part # AOA6007
Extension Arm (C)
(1) PIVOT BRAKE

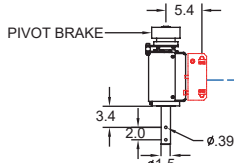

Part # AOA6001
Extension Arm (D)

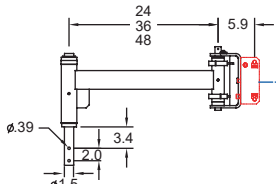

Part # AOA6009
Extension Arm (E)
(1) PIVOT BRAKE

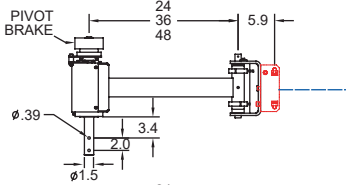

Part # AOA6010
Extension Arm (F)
(1) PIVOT BRAKE

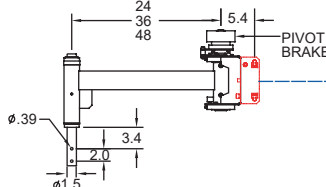

Part # AOA6011
Extension Arm (G)
(2) PIVOT BRAKE

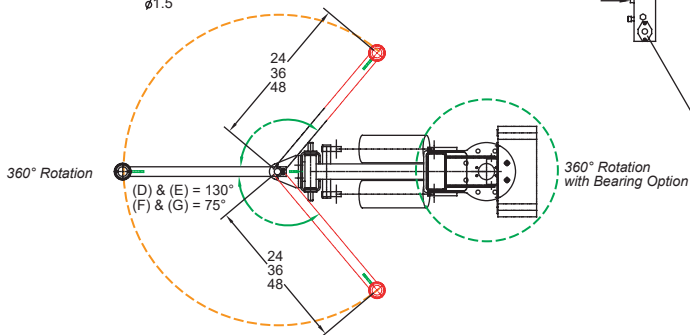
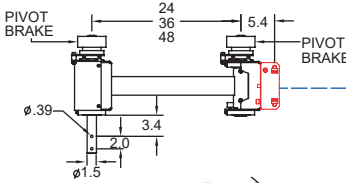

Arm Capacity reduced by weight of arm extension

Weight of Arm Extensions						
Ext. Arm (B)	Ext. Arm (C)	Reach	Ext. Arm (D)	Ext. Arm (E)	Ext. Arm (F)	Ext. Arm (G)
24.3 lbs. 11kg	35.8 lbs. 16kg	24" 609mm	42 lbs. 19kg	61 lbs. 27kg	59 lbs. 26kg	77 lbs. 35kg
		36" 914mm	47 lbs. 21kg	66 lbs. 30kg	63 lbs. 28kg	82 lbs. 37kg
		48" 1219mm	52 lbs. 23kg	72 lbs. 32kg	68 lbs. 30kg	87 lbs. 44kg

Arm Accessories

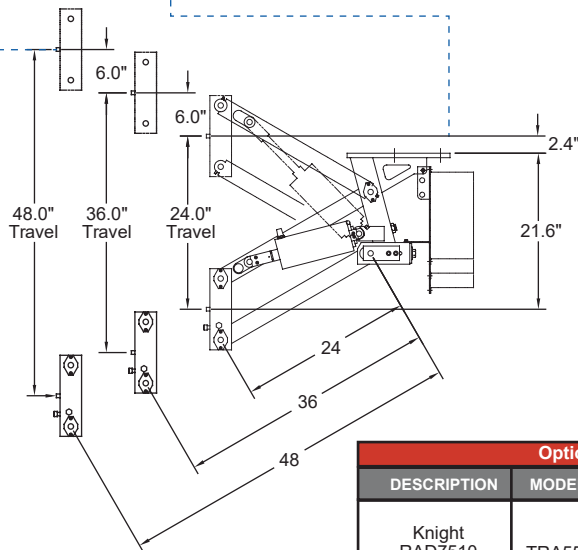
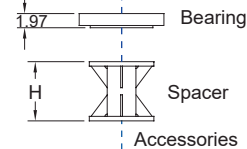
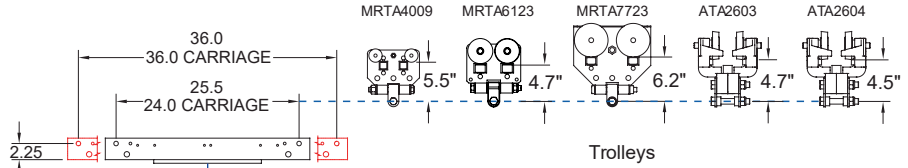
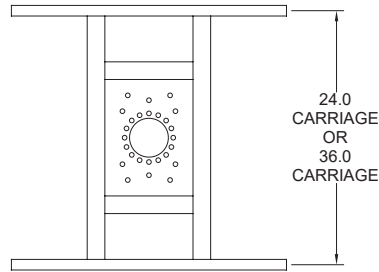

Optional		
DESCRIPTION	MODEL #	
Knight RAD7510 Air Tractor	TRA5500	
Knight Rail Brake	MRAA4359	

ORDER # EX: 6_24_G48_H99_J_L24

Optional [Omit if not required]					
Arm Desc.	Arm Length	Arm Extension	Spacer	Bearing	Carriage
6X	X	XXX	XXX	X	XXX
	24 36 48	B C	Specify Length (Inches) HXX	J = yes K = no	L24 L36
ARM			ARM ACCESSORIES		

AAA6000 Series



Knight AAA6000 Medium Duty Pedestal Mounted Arm

Knight's AAA6000 Medium Duty Arm reduces fatigue by absorbing torque reaction and lifting/manipulating product effortlessly for the operator. The AAA6000 Articulating Arm is used to lift, rotate, balance, and move product from conveyors, dunnage, assembly lines and more. Knight's AAA6000 is ideal for limited overhead applications and features a variety of control configurations.

Knight offers fixed and 360 degree rotational AAA6000 Articulating Arms. Knight Global's AAA6000 Articulating Arm has a maximum reach (without Extension Boom) of 48 in. [1,219mm] and a maximum lifting/balance capacity of up to 430 lbs. [195kg] at 100 psi [6.8bar]. Capacities vary with reach; for more information contact a Knight Global representative.

Features

- CE Compliant **
- Lifts, Rotates, Balances, and Manipulates product with minimal effort.
- Variety of Control Configurations.
- Max. Arm Length: Up to 48 in. [1,219mm].
- Max. Extension Boom Length: Up to 48in. [1,219mm] (Lengths over 48 in. Contact a Knight Representative).
- Max. Vertical Arm Travel: Up to 48 in. [1,219mm].

**CE compliance is not a standard feature on Knight Global Pneumatic Arms. Please contact us for more details.

Benefits

- Overhead Mounted Configuration Available.
- Eliminates need for overhead system.
- Reduces Operator Fatigue.
- Arm travels on the "X", "Y", and "Z" Axis.
- Absorbs Torque Reaction.
- Fixed or 360° Rotation.
- Optional Pivot Brake.
- Optional Parking Brake.
- Optional Clutch Brake.

Arm Lifting Capacity			
Reach	60 P.S.I.	80 P.S.I.	100 P.S.I.
24 in. 609mm	240 lbs. 108kg	325 lbs. 147kg	430 lbs. 195kg
36 in. 914mm	190 lbs. 86kg	265 lbs. 120kg	335 lbs. 152kg
48 in. 1219mm	100 lbs. 45kg	185 lbs. 84kg	250 lbs. 113kg

*** Arm Capacity varies by reach of Arm; Arm Capacity reduced by weight of arm extension ***

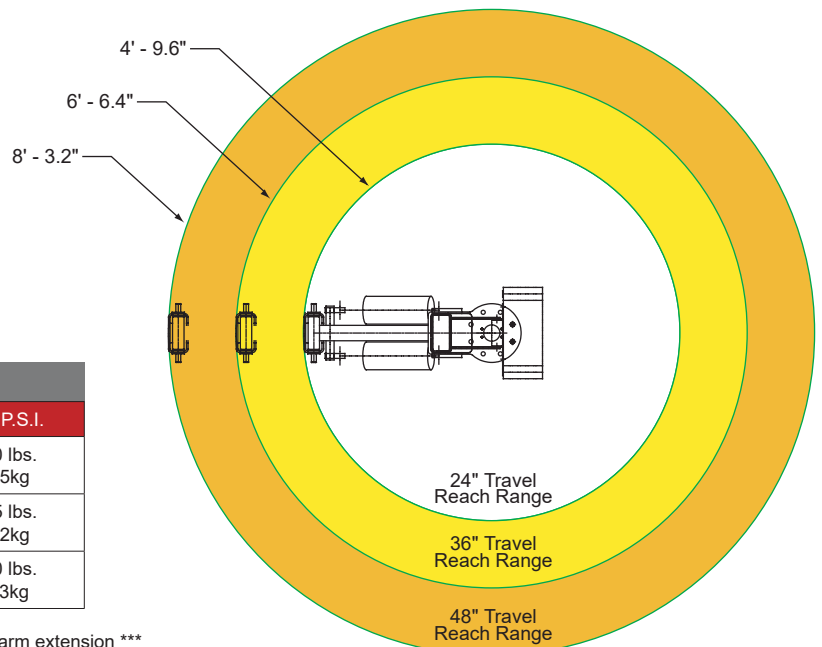

AAA6000 Series

Arm Extensions

Part # AOA6005
Extension Arm (B)

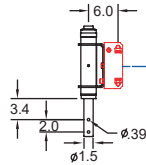

Part # AOA6007
Extension Arm (C)
(1) PIVOT BRAKE

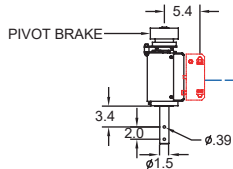

Part # AOA6001
Extension Arm (D)

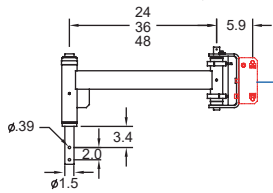

Part # AOA6009
Extension Arm (E)
(1) PIVOT BRAKE

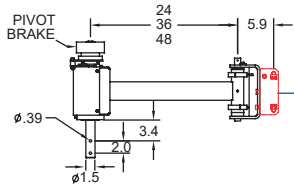

Part # AOA6010
Extension Arm (F)
(1) PIVOT BRAKE

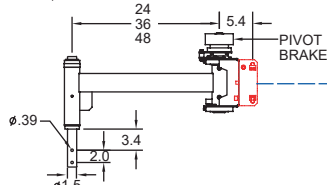

Part # AOA6011
Extension Arm (G)
(2) PIVOT BRAKE

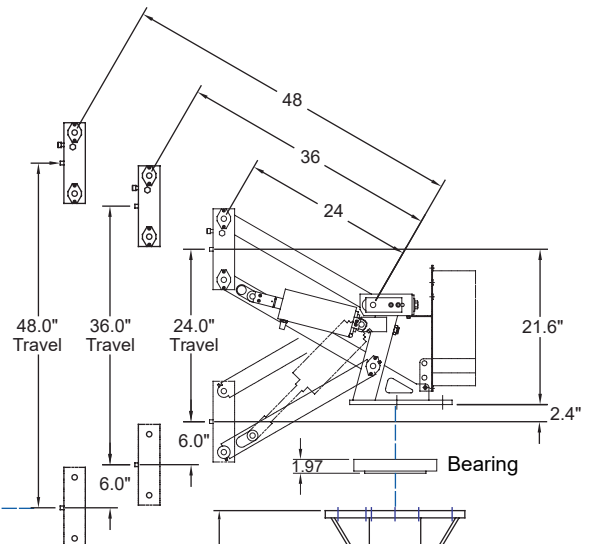
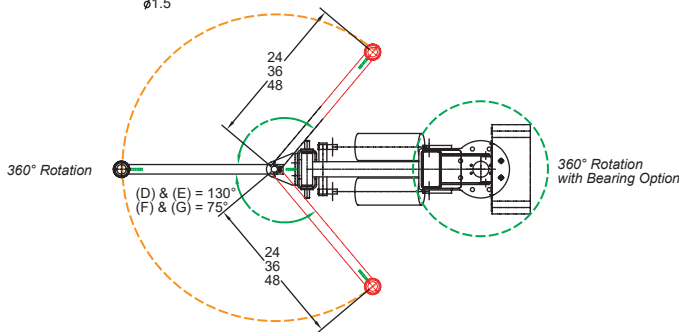
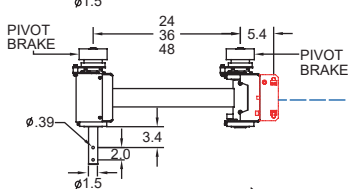

Pedestal Options

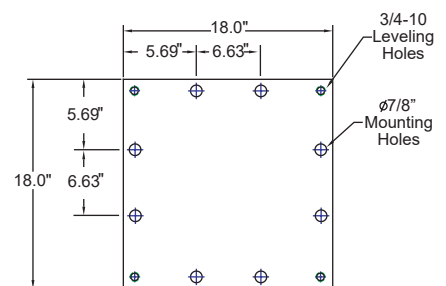
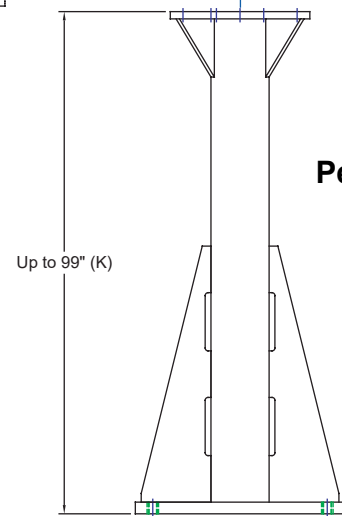

Weight of Arm Extensions

Ext. Arm (B)	Ext. Arm (C)	Reach	Ext. Arm (D)	Ext. Arm (E)	Ext. Arm (F)	Ext. Arm (G)
24.3 lbs. 11kg	35.8 lbs. 16kg	24" 609mm	42 lbs. 19kg	61 lbs. 27kg	59 lbs. 26kg	77 lbs. 35kg
		36" 914mm	47 lbs. 21kg	66 lbs. 30kg	63 lbs. 28kg	82 lbs. 37kg
		48" 1219mm	52 lbs. 23kg	72 lbs. 32kg	68 lbs. 30kg	87 lbs. 44kg

ORDER # EX: P6_24_G48_H_K99

Optional [Omit if not required]

Arm Desc.	Arm Length	Arm Extension	Bearing	Pedestal Height
P6	XX	XXX	X	XXX
	24 36 48	B C D24, D36, or D48 E24, E36, or E48 F24, F36, or F48 G24, G36, or G48	H = yes J = no	Specify Height (Inches) KXX
ARM		ARM ACCESSORIES		

AAA9000 Series



Knight AAA9000 Heavy Duty Overhead Mounted Arm

Knight's Overhead Mounted AAA9000 travels inside Knight's RAD4110, RAD6110, or RAD7510 Aluminum Series Rail Systems. Knight's AAA9000 Medium Duty Arm reduces fatigue by absorbing torque reaction and lifting/manipulating product effortlessly for the operator. The AAA9000 Articulating Arm is used to lift, rotate, balance, and move product from conveyors, dunnage, assembly lines and more. Knight's AAA6000 travels on the "X", "Y", and "Z" axis and features a variety of control configurations.

Knight offers fixed and 360 degree rotational AAA9000 Articulating Arms. Knight Global's AAA9000 Articulating Arm has a maximum reach (without Extension Boom) of 60 in. [1,524mm] and a maximum lifting/balance capacity of up to 600 lbs. [272kg] at 100 psi [6.8bar]. Capacities vary with reach; for more information contact a Knight Global representative.

Features

- CE Compliant **
- Lifts, Rotates, Balances, and Manipulates product with minimal effort.
- Variety of Control Configurations.
- Max. Arm Length: Up to 60 in. [1,524mm].
- Max. Extension Boom Length: Up to 48in. [1,219mm] (Lengths over 48 in. Contact a Knight Representative).
- Max. Vertical Arm Travel: Up to 60 in. [1,524mm].

**CE compliance is not a standard feature on Knight Global Pneumatic Arms. Please contact us for more details.

Benefits

- Pedestal Mounted Configuration Available.
- Reduces Operator Fatigue.
- Arm travels on the "X", "Y", and "Z" Axis.
- Absorbs Torque Reaction.
- Fixed or 360° Rotation.
- Optional Pivot Brake.
- Optional Parking Brake.
- Optional Clutch Brake.

Arm Lifting Capacity			
Reach	60 P.S.I.	80 P.S.I.	100 P.S.I.
36 in. 914mm	400 lbs. 181kg	600 lbs. 272kg	600 lbs. 272kg
48 in. 1219mm	300 lbs. 136kg	425 lbs. 192kg	525 lbs. 238kg
60 in. 1524mm	225 lbs. 102kg	350 lbs. 158kg	400 lbs. 181kg

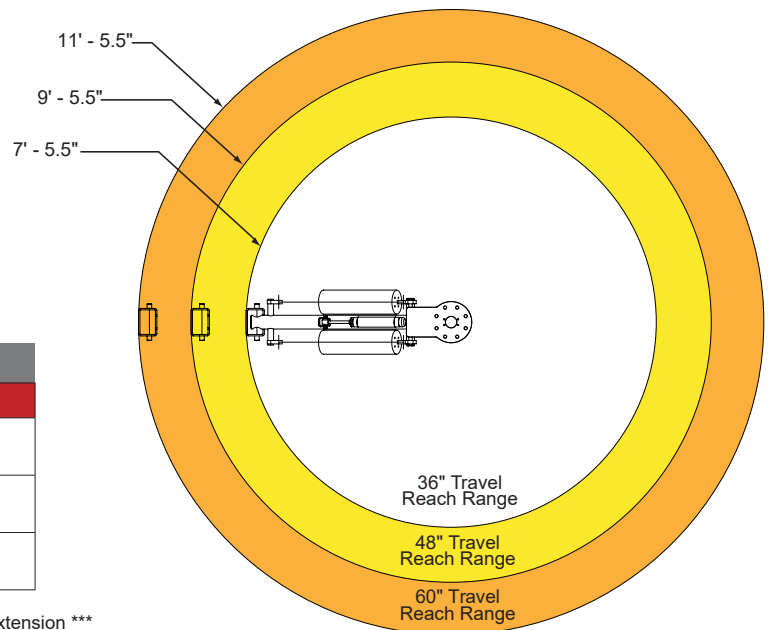

*** Arm Capacity varies by reach of Arm; Arm Capacity reduced by weight of arm extension ***

AAA9000 Series

Arm Extensions

Part # AOA7007
Extension Arm (B)
(1) PIVOT BRAKE

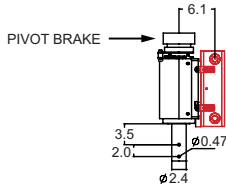

Part # AOA7001
Extension Arm (C)

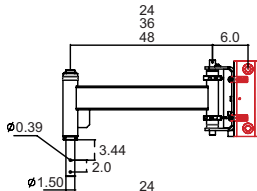

Part # AOA7009
Extension Arm (D)
(1) PIVOT BRAKE

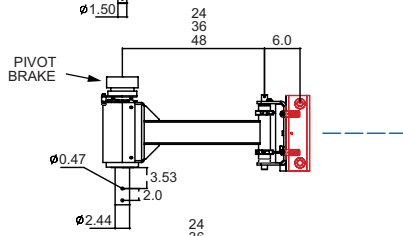

Part # AOA7010
Extension Arm (E)
(1) PIVOT BRAKE

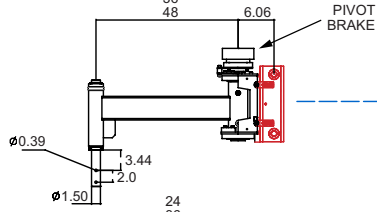

Part # AOA7011
Extension Arm (F)
(2) PIVOT BRAKE

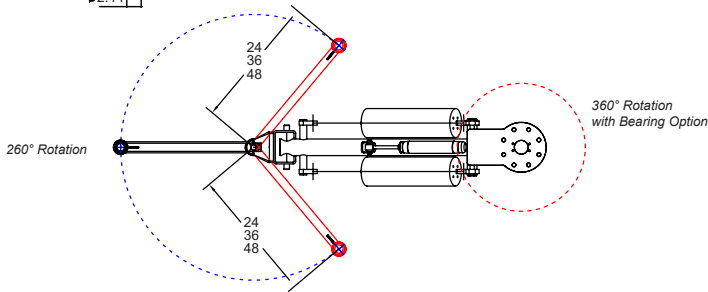
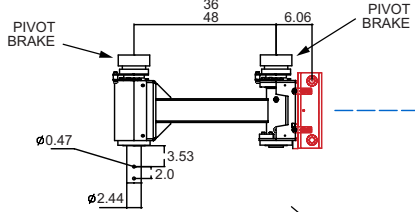

Arm Accessories

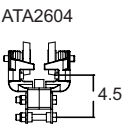
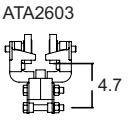
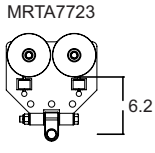
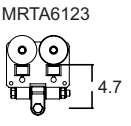
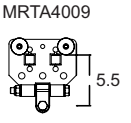
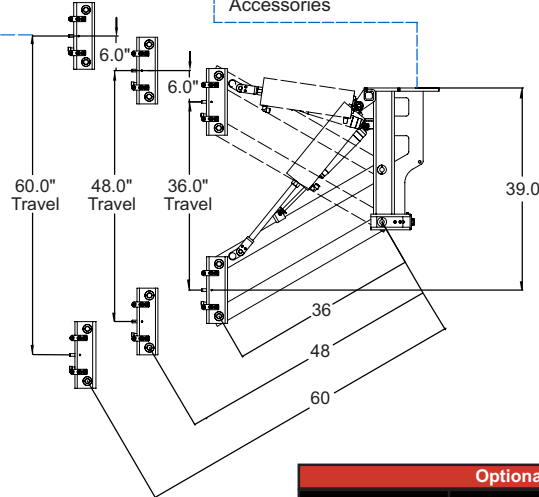
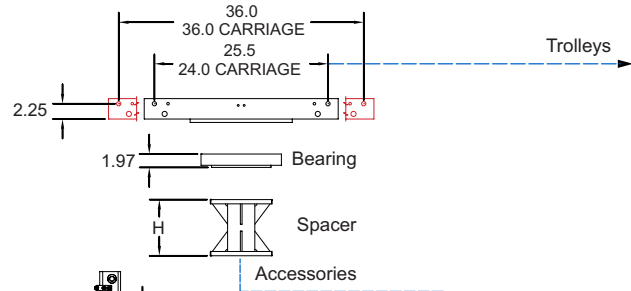
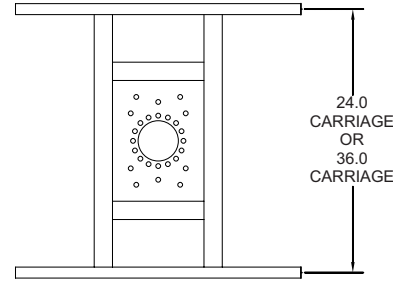

Optional		
DESCRIPTION	MODEL #	
Knight RAD7510 Air Tractor	TRA5500	
Knight Rail Brake	MRAA4359	

ORDER # EX: 9_36_F48_G99_H_J24

Optional [Omit if not required]

Arm Desc.	Arm Length	Arm Extension	Spacer	Bearing	Carriage
9	XX	XXX	XXX	X	XXX
	36 48 60	B C24, C36, or C48 D24, D36, or D48 E24, E36, or E48 F24, F36, or F48	Specify Length (Inches) GXX	H = yes I = no	J24 J36
ARM		ARM ACCESSORIES			

Weight of Arm Extensions

Ext. Arm (B)	Reach	Ext. Arm (C)	Ext. Arm (D)	Ext. Arm (E)	Ext. Arm (F)
64.6 lbs. 29.3kg	24" 609mm	53 lbs. 24kg	99.5 lbs. 45kg	91.2 lbs. 41kg	138 lbs. 63kg
	36" 914mm	62.2 lbs. 28kg	109 lbs. 50kg	100 lbs. 45kg	146 lbs. 66kg
	48" 1219mm	71.4 lbs. 32kg	118 lbs. 53kg	110 lbs. 50kg	156 lbs. 70kg

Arm Capacity reduced by weight of arm extension

AAA9000 Series



Knight AAA9000 Heavy Duty Pedestal Mounted Arm

Knight's Floor Mounted AAA9000 Heavy Duty Arm reduces fatigue by absorbing torque reaction and lifting/manipulating product effortlessly for the operator. The AAA9000 Articulating Arm is used to lift, rotate, balance, and move product from conveyors, dunnage, assembly lines and more. Knight's AAA9000 is ideal for limited floor mounted applications and features a variety of control configurations.

Knight offers fixed and 360 degree rotational AAA9000 Articulating Arms. Knight Global's AAA9000 Articulating Arm has a maximum reach (without Extension Boom) of 48 in. [1,219mm] and a maximum lifting/balance capacity of up to 600 lbs. [272kg] at 100 psi [6.8bar]. Capacities vary with reach; for more information contact a Knight Global representative.

Features

- CE Compliant **
- Lifts, Rotates, Balances, and Manipulates product with minimal effort.
- Variety of Control Configurations.
- Max. Arm Length: Up to 60 in. [1,524mm].
- Max. Extension Boom Length: Up to 48in. [1,219mm] (Lengths over 48 in. Contact a Knight Representative).
- Max. Vertical Arm Travel: Up to 60 in. [1,524mm].

**CE compliance is not a standard feature on Knight Global Pneumatic Arms. Please contact us for more details.

Benefits

- Overhead Mounted Configuration Available.
- Eliminates need for overhead system.
- Reduces Operator Fatigue.
- Arm travels on the "X", "Y", and "Z" Axis.
- Absorbs Torque Reaction.
- Fixed or 360° Rotation.
- Optional Pivot Brake.
- Optional Parking Brake.
- Optional Clutch Brake.

Arm Lifting Capacity			
Reach	60 P.S.I.	80 P.S.I.	100 P.S.I.
36 in. 914mm	400 lbs. 181kg	600 lbs. 272kg	600 lbs. 272kg
48 in. 1219mm	300 lbs. 136kg	425 lbs. 192kg	525 lbs. 238kg
60 in. 1524mm	225 lbs. 102kg	350 lbs. 158kg	400 lbs. 181kg

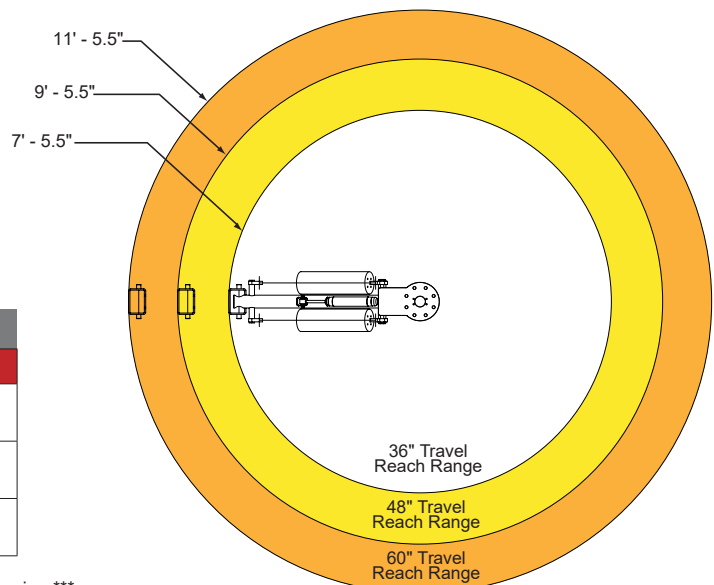

*** Arm Capacity varies by reach of Arm; Arm Capacity reduced by weight of arm extension ***

AAA9000 Series

Arm Extensions

Part # AOA7007
Extension Arm (B)
(1) PIVOT BRAKE

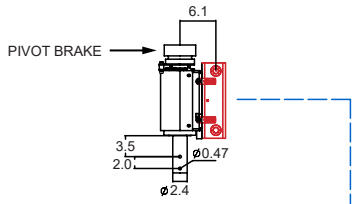

Part # AOA7001
Extension Arm (C)

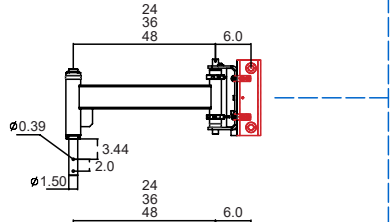

Part # AOA7009
Extension Arm (D)
(1) PIVOT BRAKE

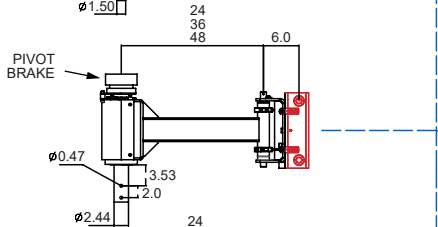

Part # AOA7010
Extension Arm (E)
(1) PIVOT BRAKE

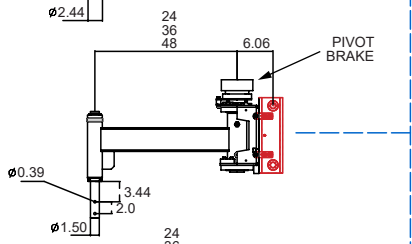

Part # AOA7011
Extension Arm (F)
(2) PIVOT BRAKE

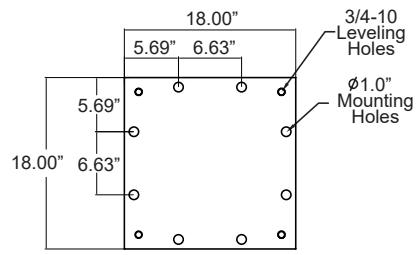
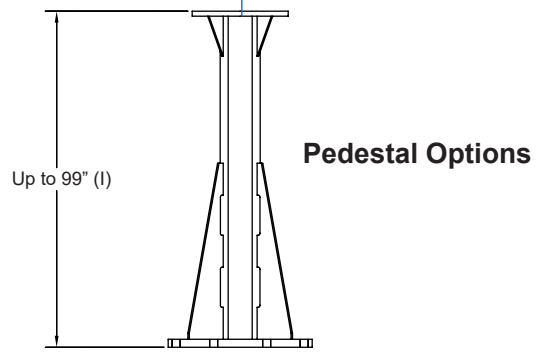
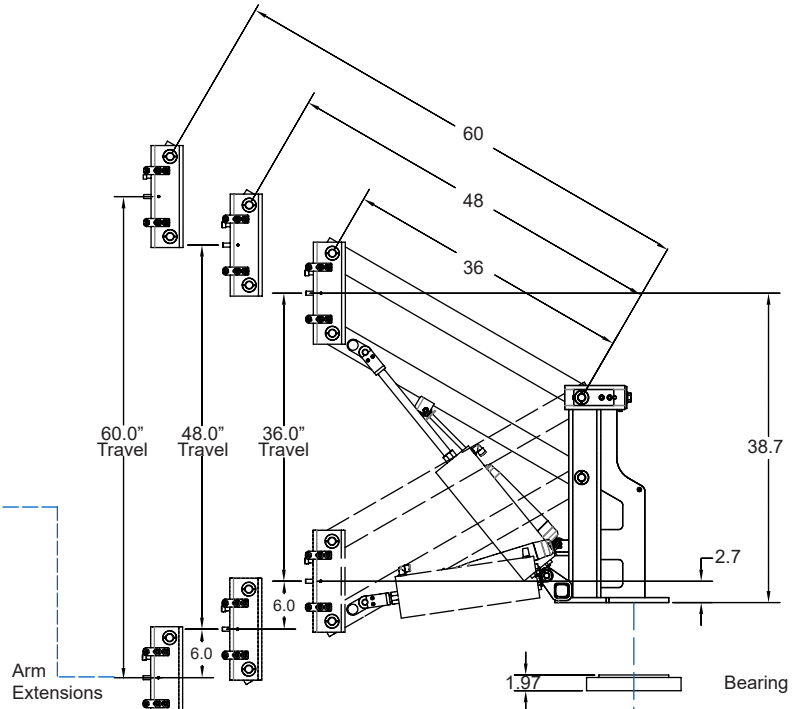
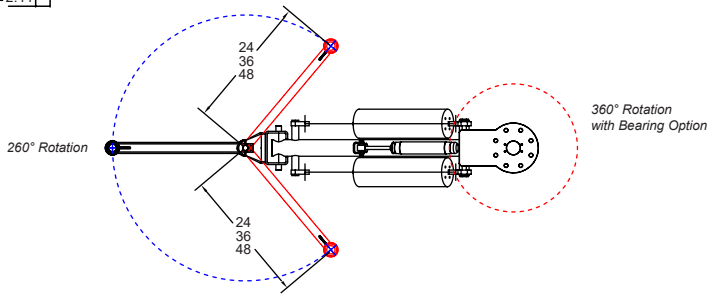
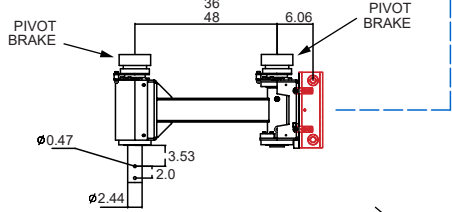

Weight of Arm Extensions					
Ext. Arm (B)	Reach	Ext. Arm (C)	Ext. Arm (D)	Ext. Arm (E)	Ext. Arm (F)
	24"	53 lbs.	99.5 lbs.	91.2 lbs.	138 lbs.
	609mm	24kg	45kg	41kg	63kg
64.6 lbs.	36"	62.2 lbs.	109 lbs.	100 lbs.	146 lbs.
29.3kg	914mm	28kg	50kg	45kg	66kg
	48"	71.4 lbs.	118 lbs.	110 lbs.	156 lbs.
	1219mm	32kg	53kg	50kg	70kg

ORDER # EX: P9_24_F48_G_I99

Optional [Omit if not required]				
Arm Desc.	Arm Length	Arm Extension	Bearing	Pedestal Height
P9	XX	XXX	X	XXX
	36 48 60	B C24, C36, or C48 D24, D36, or D48 E24, E36, or E48 F24, F36, or F48	G = Yes H = No	Specify Height (Inches) IXX
ARM		ARM ACCESSORIES		

ATA4000 Series

Knight ATA4000 Vertical Mast Arm

Knight Global's ATA4000 Vertical Mast Arm has fixed control handles that improve ergonomics by eliminating the need for an operator to bend or reach. The Vertical Mast Arm is typically used in applications that require significant UP and DOWN travel and precision placement. Knight's ATA4000 can be used with any Knight Balancer or chain hoist. Knight's Vertical Mast Arm rotates 360 degrees or can be fixed mounted for the operator.

Vertical Mast Arms are available with a round mast for direct loads only, or a square THK mast for offset / cantilevered loads.

Knight's ATA4000 also has available a bearing clutch parking brake that attaches to the Vertical Mast Arm.

Features

- CE Compliant **
- Handles in a fixed ergonomic position on the mast.
- Various Control Configurations.
- Rail Length Available: Up to 15 ft. [4.6m].
- Max. Torque: Up to 853 ft./lbs. [1,156Nm].
- Max. Vertical Travel: Varies
- **Max. Capacity: Up to 500 lbs. [226kg].**

**CE compliance is not a standard feature on Knight Global Pneumatic Arms and Balancers. Please contact us for more details.

Arm Capacity varies by reach of Arm; Arm Capacity reduced by weight of arm extension

Benefits

- Can be used with a Knight Balancer or Chain Hoist.
- Reduces Operator Fatigue.
- 360° Rotation or Fixed Mounted.
- Optional Parking Brake.
- Optional Bearing Clutch.



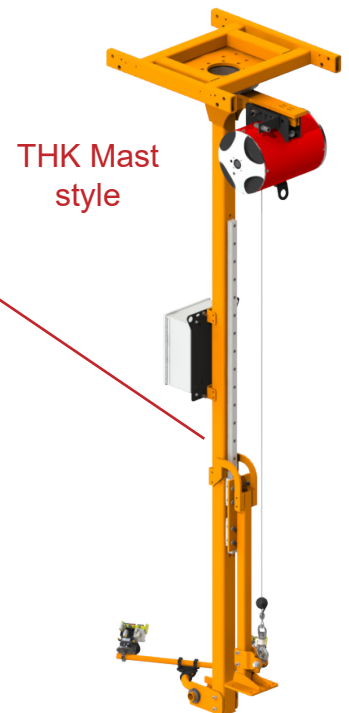
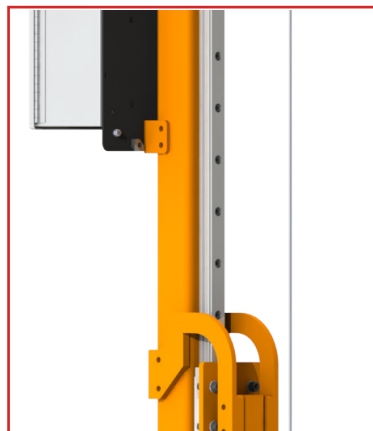

Round Mast style







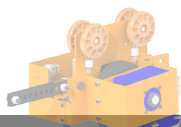
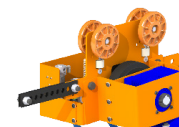

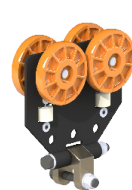
THK Mast style

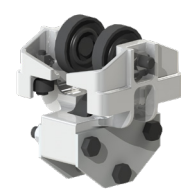
Pneumatic Arm Accessories

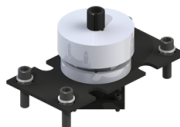
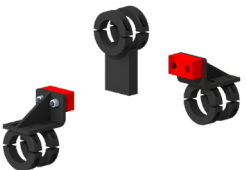
Knight Global Arm Accessories contain a wide variety of accessories that include; Trolleys for Rail Systems, Air Balancer Pulleys, Hooks and Safety Cable Kits.

TRA5000-Series Air Tractor	TRA5500 Series Lube-Free Motor	MRTA4009 Load Trolley with Yoke	MRTA6123 Load Trolley with Yoke	MRTA7723 Load Trolley with Yoke
 <p>OBSOLETE</p> <ul style="list-style-type: none"> • Maximum Speed: 1.9 ft. per min [1.3mph]. • Assists operator in pushing, pulling and positioning loads. • Maximum Towing Capacity: Up to 2,000 lbs. [908kg]. 	 <ul style="list-style-type: none"> • Maximum Speed: 1.9 ft. per sec. [1.3mph]. • Less maintenance and longer service life expected by running on a lube-free motor. • Maximum Towing Capacity: Up to 2,000 lbs. [908kg]. 	 <ul style="list-style-type: none"> • Fiberglass filled High Impact Nylon Wheels. • Side Guide Rollers with integrated bearings. • Max. Capacity: Up to 1,100 lbs. [499kg]. 	 <ul style="list-style-type: none"> • Double-Shielded bearings keep dirt out, and do not require lubrication. • Min/ Max Continuous Service Temp at 100% load: -20 degs. F to 248 degs. F. • Max. Capacity: Up to 1,600 lbs. [725kg]. 	 <ul style="list-style-type: none"> • Transfers loads along the horizontal axis. • Primarily used to attached the balancer to a overhead rail system. • Max. Capacity: Up to 3000 lbs. [1,360kg].

ATA2603 Flat I-Beam Load Trolley	ATA2604 S-Beam Load Trolley	ASA9510 Parking Brake	ASA9522 Clutch Bearing Brake	AAA4005 Arm Stop Assembly
 <ul style="list-style-type: none"> • Travels along a 3.25 in. [82.55mm] or 3.33 in. [84.58mm] I-Beam. • Suspends Knight's ATA2600 or ATA2700 Torque Tubes. 	 <ul style="list-style-type: none"> • Travels along a 2.66 in. [67.56mm] flange or a 4.00 in. [101.6mm] S-Beam. • Suspends Knight's ATA2600 or ATA2700 Torque Tubes. 	 <ul style="list-style-type: none"> • Attaches to a pneumatic arm bearing to allow an arm to be parked when not in use. • Can be integrated with fixture controls to accommodate the user. 	 <ul style="list-style-type: none"> • Attaches to a pneumatic arm carriage pan to allow an arm to be parked when not in use. • Eliminates any vertical rotation on the main bearing. • Can be integrated with fixture controls to accommodate the user. 	 <ul style="list-style-type: none"> • Attaches to light duty pneumatic arms. • Manual stopping system. • Easy bolt-on design • Adjustable.

RWA4133 Safety Cable Kit	CAMIRWA4133 Nycro-Press Safety Cable Kit	FDA4133 Eye Bolt Safety Cable Kit
 <ul style="list-style-type: none"> • Carbon Steel "Galvanized Wire Rope" GWC. • Cable Thickness: 0.25 in. [6mm]. • Crosby Saddle Clamps. • Standard lengths: 5 ft. [1.5m]. 	 <ul style="list-style-type: none"> • Carbon Steel "Galvanized Wire Rope" GWC. • Cable Thickness: 0.25 in. [6mm]. • Copper Zinc Plated Oval Sleeves. • Standard lengths: 5 ft. [1.5m]. 	 <ul style="list-style-type: none"> • Carbon Steel "Galvanized Wire Rope" GWC. • Cable Thickness: 0.25 in. [6mm]. • Crosby Saddle Clamps. • Eye Bolt Connection. • Standard lengths: 6 ft. [1.82m].

KEAA2000 Series

Knight KEAA2000 Dual Bridge Extension Arm

Knight Global's KEAA2000 Series Dual Bridge Extension Arms enable the operator to extend beyond the working limits of an overhead rail system within a workstation. A Knight Pneumatic/Air Balancer mounts to the extension arm allowing for a controlled lifting and lowering of loads. Knight's KEAA2000 travels inside Knight's RAD4110, RAD6110, or RAD7510 Aluminum Series Rail Systems.

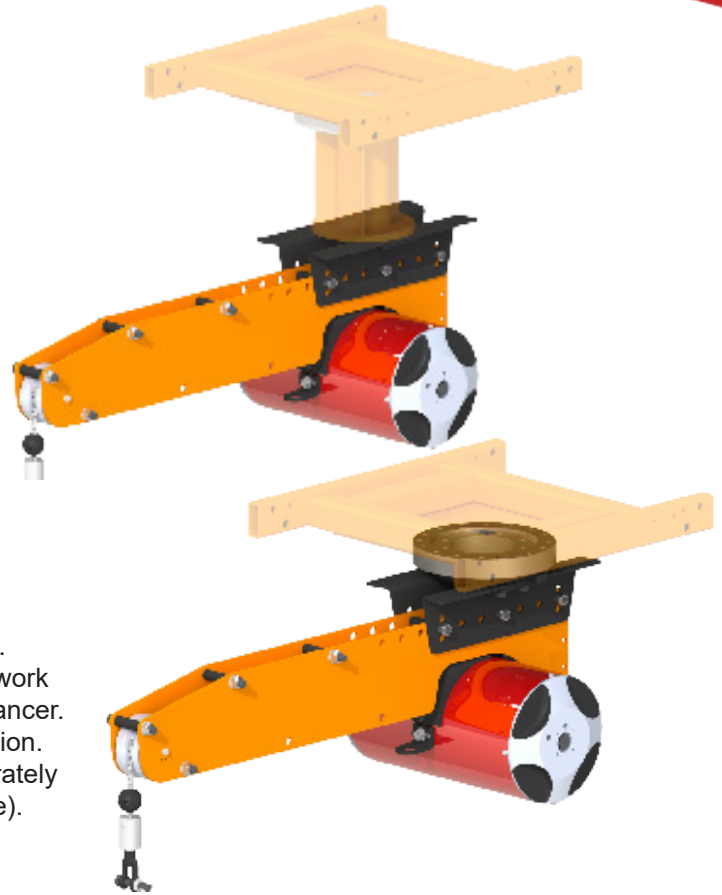

Features

- Dual Bridge Configuration.
- Travels inside Knight's **RAD4110**, **RAD6110**, or **RAD7510** Series Rail.
- CE Compliant upon Request. **
- Various Control Configurations.
- Angular Adjustment in **10°** increments. (**10° UP / 10° DOWN**)
- Horizontal Adjustments: Up to **6.8 in. [172mm]**. in **2.3 in.** Increments.
- Requires Non-Lubricated Clean/Dry Air.
- Max Balancing Capacity: Up to **700 lbs. [317kg]**.

** CE compliance is not a standard feature on Knight Global Pneumatic Balancers. Please contact us for more details.

Benefits

- Chain Configuration.
- Expands the reach work area of a typical balancer.
- Allows for 360° rotation.
- Controls Sold Separately (Up/Down or Balance).

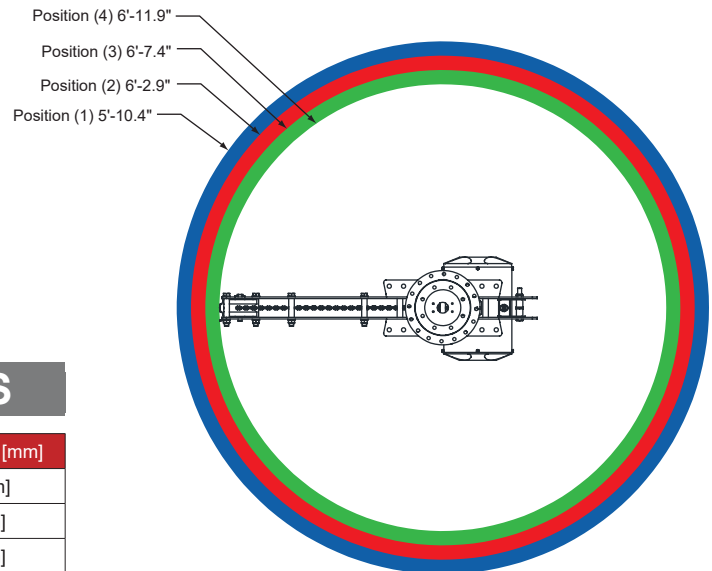

(4) Position Adjustments

KEAA2000 SERIES CAPACITIES

Model	Rated Capacity lbs. [kg]	Maximum Travel in. [mm]
KEAA2000-200	200 lbs. [90kg]	110 in. [2794mm]
KEAA2000-350	350 lbs. [158kg]	67 in. [1701mm]
KEAA2000-500	500 lbs. [226kg]	80 in. [2032mm]
KEAA2000-700	700 lbs. [317kg]	50 in. [1270mm]

*** Arm Capacity varies by reach of Arm; Arm Capacity reduced by weight of arm extension ***

Formula for Air Balancer sizing:

Example: plant air 80 psi, 350 air balancer, 80% load capability (0.80 air supply x 350 lbs. = 280 x .80 = 224 lbs. load capability).

KEAA2000 Series

ARM ACCESSORIES

Trolleys
(Custom Trolleys Available)

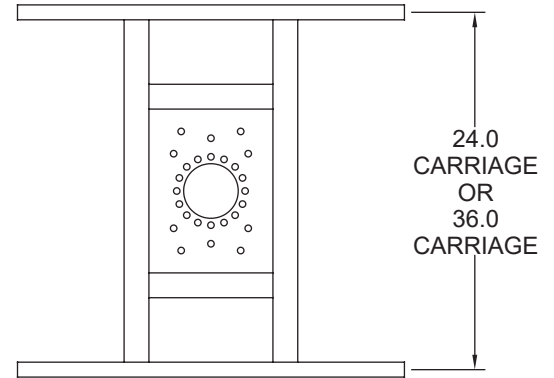
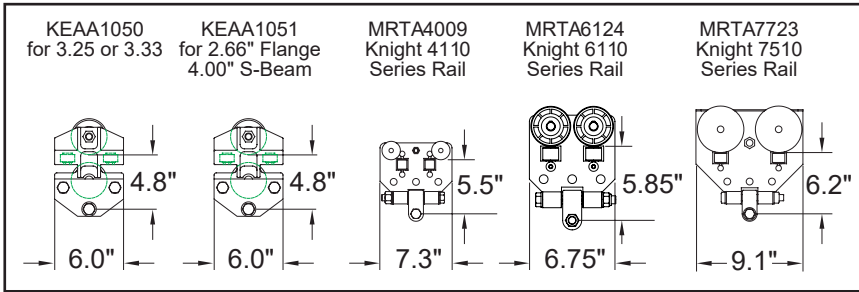

KBC KBC
200 and 350

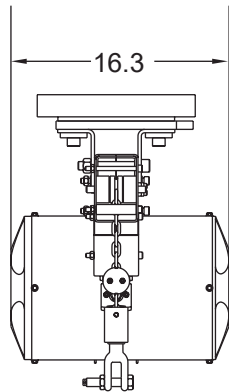

KBC KBC
500 and 700

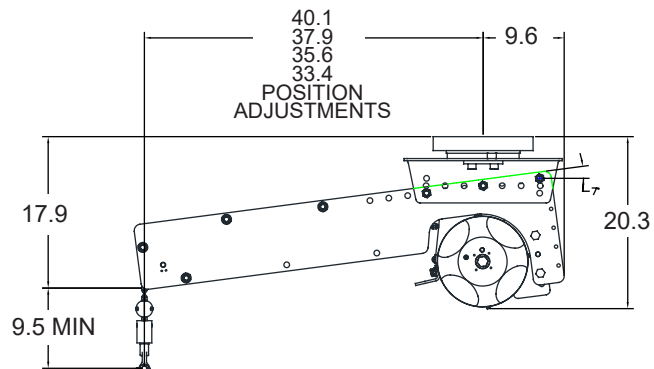
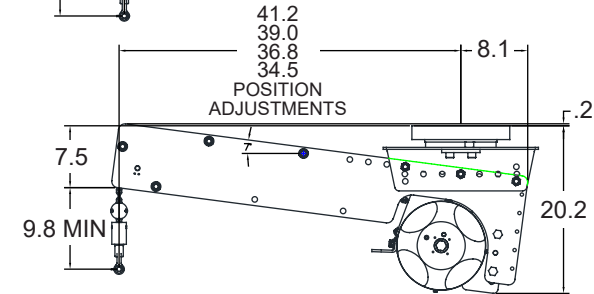
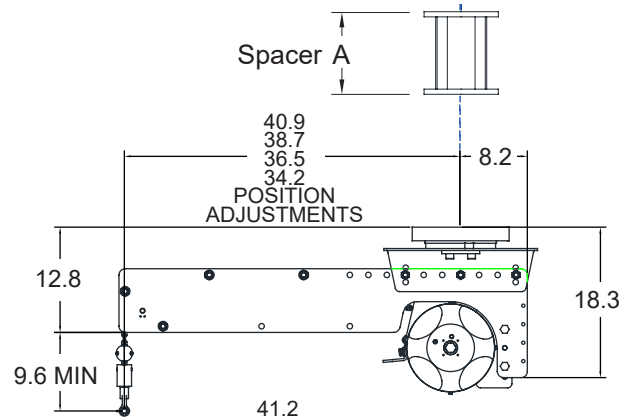
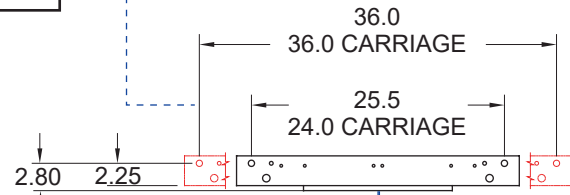
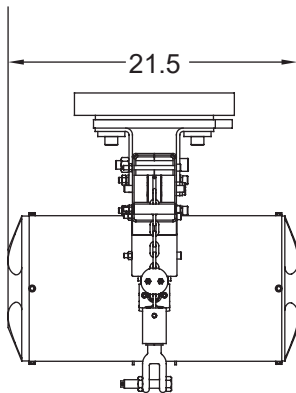

EXAMPLE:
ORDER # : KEAA20_500_A36_B24

Optional [Omit if not required]			
Arm Desc.	Capacity	Spacer	Carriage
KEAA20	XXX	XXX	XXX
	200 350 500 700	Specify Length [Max 36"] (Inches) AXX	B24 B36
ARM		ARM ACCESSORIES	

KEAA2500 Series

Knight KEAA2500 Single Bridge Extension Arm

Knight Global's KEAA2500 Series Single Bridge Extension Arms enable the operator to extend beyond the working limits of an overhead rail system within a workstation. A Knight Pneumatic/Air Balancer mounts to the extension arm allowing for a controlled lifting and lowering of loads. Knight's KEAA2500 travels inside Knight's RAD4110, RAD6110, or RAD7510 Aluminum Series Rail Systems.

The KEAA2500 Series Extension Arm can be adjusted to (4) different positions.

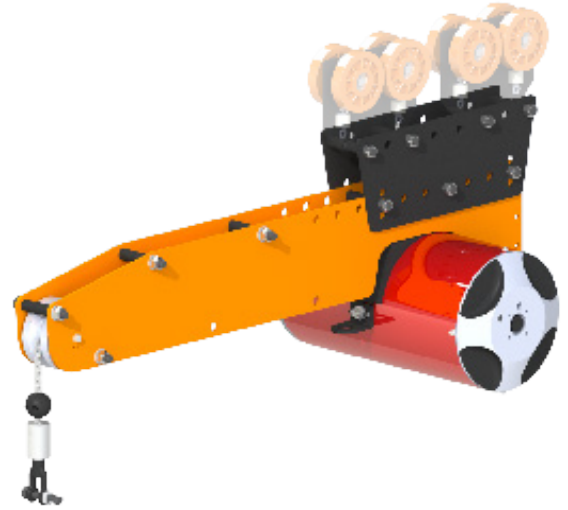

Features

- Single Bridge Configuration.
- Travels inside Knight's **RAD4110**, **RAD6110**, or **RAD7510** Series Rail.
- CE Compliant. **
- Various Control Configurations.
- Angular Adjustment in **10°** increments. (**10° UP / 10° DOWN**)
- Horizontal Adjustments:
Up to **6.8 in. [172mm]**. in **2.3 in.** Increments.
- Requires Non-Lubricated Clean/Dry Air.
- Max Balancing Capacity:
Up to **700 lbs. [317kg]**.

** CE compliance is not a standard feature on Knight Global Pneumatic Balancers. Please contact us for more details.

Benefits

- Chain Configuration.
- Expands the reach work area of a typical balancer.
- Controls Sold Separately (Up/ Down or Balance).

KEAA2500 SERIES CAPACITIES

Model	Rated Capacity lbs. [kg]	Maximum Travel in. [mm]
KEAA2500-200	200 lbs. [90kg]	110 in. [2794mm]
KEAA2500-350	350 lbs. [158kg]	67 in. [1701mm]
KEAA2500-500	500 lbs. [226kg]	80 in. [2032mm]
KEAA2500-700	700 lbs. [317kg]	50 in. [1270mm]

Formula for Air Balancer sizing:

Example: plant air 80 psi, 350 air balancer, 80% load capability
(0.80 air supply x 350 lbs. = 280 x .80 = 224 lbs. load capability).

*** Arm Capacity varies by reach of Arm; Arm Capacity reduced by weight of arm extension***

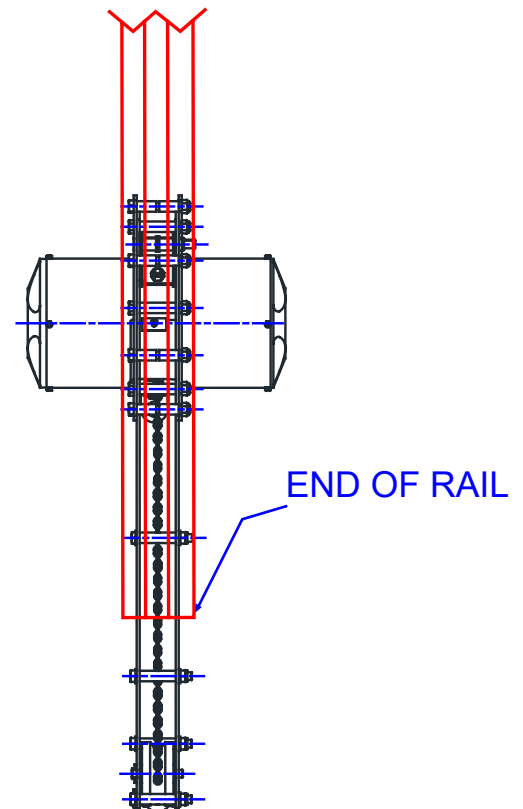

KEAA2500 Series

Arm Accessories

Trolleys (Custom Trolleys Available)

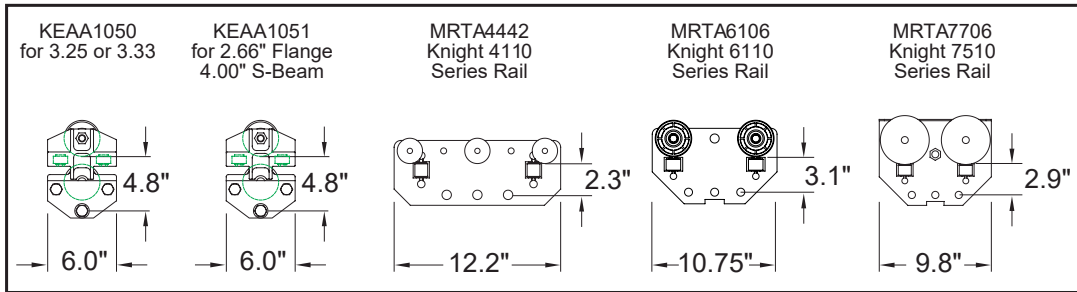

KBC KBC
200 and 350

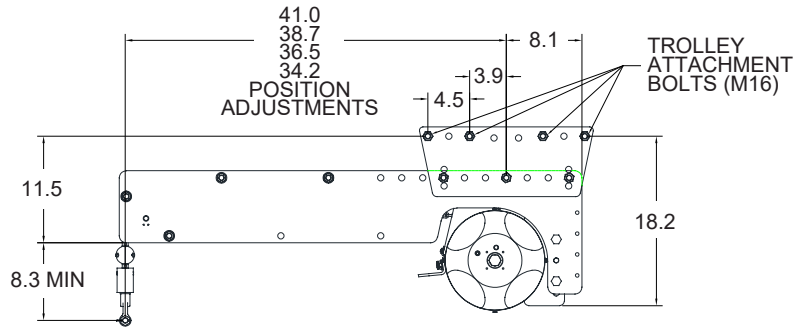
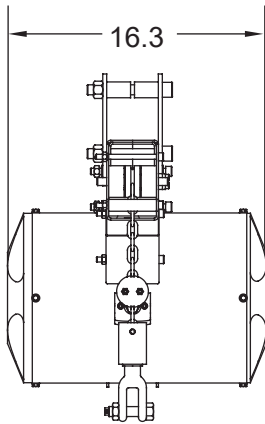

KBC KBC
500 and 700

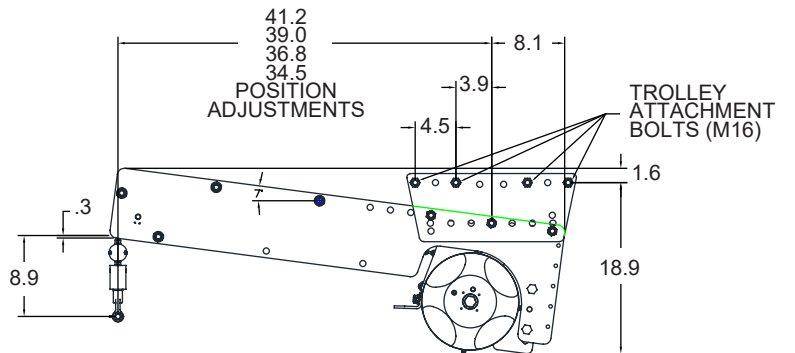
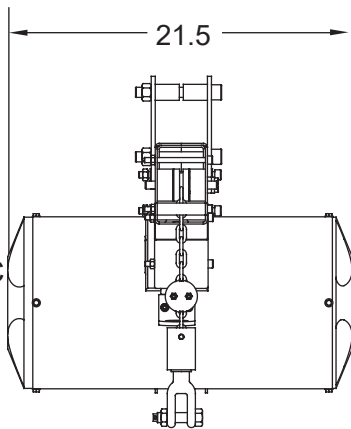



EXAMPLE:
ORDER #: KEAA25_500

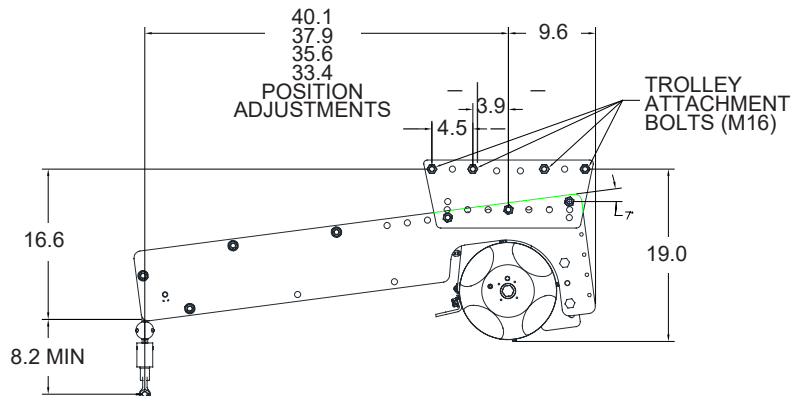

Arm Desc.	Capacity
KEAA25	XXX
	200
	350
	500
	700

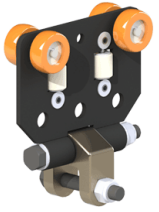

KEAA Series Arm Accessories

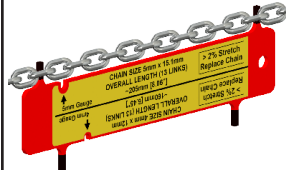
Knight Global Arm Accessories contain a wide variety of accessories that include; Trolleys for Rail Systems, Air Balancer Pulleys, Hooks and Safety Cable Kits.

MRTA4009 Load Trolley with Yoke	MRTA6123 Load Trolley with Yoke	MRTA7723 Load Trolley with Yoke	KSAA1003 Chain Wear Gauge
 <ul style="list-style-type: none"> • Travels inside RAD4110 Series Rail. • Side Guide Rollers with integrated bearings. • Max. Capacity: Up to 1,100 lbs. [499kg]. 	 <ul style="list-style-type: none"> • Travels inside RAD6110 Series Rail. • Side Guide Rollers with integrated bearings. • Max. Capacity: Up to 1,600 lbs. [725kg]. 	 <ul style="list-style-type: none"> • Travels inside RAD7510 Series Rail. • Side Guide Rollers with integrated bearings. • Max. Capacity: Up to 3,000 lbs. [1,360kg]. 	 <ul style="list-style-type: none"> • Used to measure the wear on pneumatic air balancers 4mm/5mm galvanized chain.

RWA4133 Safety Cable Kit	CAMIRWA4133 Nycro-Press Safety Cable Kit	FDA4133 Eye Bolt Safety Cable Kit
 <ul style="list-style-type: none"> • Carbon Steel "Galvanized Wire Rope" GWC. • Cable Thickness: 0.25 in. [6mm]. • Crosby Saddle Clamps. • Standard lengths: 5 ft. [1.5m]. 	 <ul style="list-style-type: none"> • Carbon Steel "Galvanized Wire Rope" GWC. • Cable Thickness: 0.25 in. [6mm]. • Copper Zinc Plated Oval Sleeves. • Standard lengths: 5 ft. [1.5m]. 	 <ul style="list-style-type: none"> • Carbon Steel "Galvanized Wire Rope" GWC. • Cable Thickness: 0.25 in. [6mm]. • Crosby Saddle Clamps. • Eye Bolt Connection. • Standard lengths: 6 ft. [1.82m].

KSHCA Series



KSHCA Overhead Carriage Mounted Articulating Servo Hoist Arm

Knight Global's KSHCA Series Overhead Carriage-Mounted Servo Hoist Arm provides an operator with the capabilities to reach outside the area directly below a rail system and to precisely locate or float a load in the "Z" direction (vertical axis) with speed, precision, quality, unmatched reliability and repeatability. The KSHCA Series Servo Arm allows for overhead reach that varies depending on the design of the work cell or station.

Mechanical Features

- Speeds: Up to **98 ft/min. [30 m/min]**.
- Maximum Lifting Capacity:
Up to **1,500 lbs. [680kg]**.
- Maximum Reach of Extension:
Up to **48 in. [1,219 mm]**.
(Boom / End Effector length not included)
- Safety Rating of 125%.
- Fail-Safe Brake.
- Overhead Mounted Carriage.
- Chain Lengths
(12 - 20 ft. Standard).
- Sealed Worm Style Gearbox.
- H5 Rated (Continuous Duty Cycle).

Software Features

- Programming and Diagnostic Communication Ports.
- Virtual Travel Limits.
- Speed Reduction Zones.
- Impact Limiting.
- Active Dampening.
- Knight's Unique "Float" Mode.
- Programmable Overload Capability.

Electrical Features

- Industry Standard 24 VDC, 2 AMP power is available for custom tooling such as:
Clamps, Vacuum Cups, Switches, Proximity Limits, Lights, etc.
- Enable trigger, for quicker response.
- 240 VAC, Single Phase 50/60 Hz.
- Load Sensing, Part Weight and Handle Force.
- I/O Capabilities:
 - (4) Analog Inputs and (4) Analog Outputs
 - (24) Inputs or Outputs, configurable
 - (8) Dedicated Inputs.
 - Expansion I/O: Ethernet, Unlimited.
- LED Status Indicators: Green and Blue Lighted Push Buttons.
- LED Fault Indicator: Illuminated Red Run-Stop Button, Twist to Release.
- Optional: **Remote Pendant** or **Wireless Remote Control**.

KSHCA Series Overhead Carriage Mounted Servo Hoist Arm Specifications

Part Number	Capacity lbs [kg]	Maximum Speed ft/min. [m/min]	Voltage / Phase
KSHCA500-2401	500 lbs. [227kg]	98 ft/min. [30 m/min]	240 / 1 Phase
KSHCA1000-2401	1000 lbs. [454kg]	82 ft/min. [25 m/min]	240 / 1 Phase
KSHCA1500-2401	1,500 lbs. [680kg]	66 ft/min. [20 m/min]	240 / 1 Phase

KSHFA Series

KSHFA Floor Mounted Articulating Servo Hoist Arm

Knight Global's KSHFA Series Floor-Mounted Servo Hoist Arm enables an operator to precisely locate or float a load in the "Z" direction (vertical axis) with speed, precision, quality, unmatched reliability and repeatability. The KSHFA Series Servo Arm allows for overhead reach that varies depending on the design of the work cell or station. Knight's Floor-Mounted KSHFA Series is most commonly used when overhead clearances or support structures will not accommodate an overhead rail system.



Mechanical Features

- Speeds: Up to **98 ft/min. [30 m/min]**.
- Maximum Lifting Capacity:
Up to **1,500 lbs. [680kg]**.
- Maximum Reach:
Up to **48 in. [1,219 mm]**.
(Boom / End Effector length not included)
- Safety Rating of 125%.
- Fail-Safe Brake.
- Floor-Mounted Pedestal Heights:
8 ft. [2.4 m] - 10 ft. [3.0 m].
- Heavy Duty Roller Chain.
- Chain Lengths
(12 - 20 ft. Standard).
- Sealed Worm Style Gearbox.
- H5 Rated (Continuous Duty Cycle).

Software Features

- Programming and Diagnostic Communication Ports.
- Virtual Travel Limits.
- Speed Reduction Zones.
- Impact Limiting.
- Active Dampening.
- Knight's Unique "Float" Mode.
- Programmable Overload Capability.

Electrical Features

- Industry Standard 24 VDC, 2 AMP power is available for custom tooling such as:
Clamps, Vacuum Cups, Switches, Proximity Limits, Lights, etc.
- Enable trigger, for quicker response.
- 240 VAC, Single Phase 50/60 Hz.
- Load Sensing, Part Weight and Handle Force.
- I/O Capabilities:
 - (4) Analog Inputs and (4) Analog Outputs
 - (24) Inputs or Outputs, configurable
 - (8) Dedicated Inputs.
 - Expansion I/O: Ethernet, Unlimited.
- LED Status Indicators: Green and Blue Lighted Push Buttons.
- LED Fault Indicator: Illuminated Red Run-Stop Button, Twist to Release.
- Optional: **Remote Pendant** or **Wireless Remote Control**.

KSHFA Series Floor Mounted Servo Hoist Arm Specifications

Part Number	Capacity lbs [kg]	Maximum Speed ft/min [m/min]	Voltage / Phase
KSHFA500-2401	500 lbs. [227kg]	98 ft/min. [30 m/min]	240 / 1 Phase
KSHFA1000-2401	1000 lbs. [454kg]	82 ft/min. [25 m/min]	240 / 1 Phase
KSHFA1500-2401	1,500 lbs. [680kg]	66 ft/min. [20 m/min]	240 / 1 Phase

KSHEA Overhead Carriage Mounted Articulating Extension Servo Hoist Arm



Knight Global's KSHEA Series Overhead Carriage-Mounted Extension Servo Hoist Arm provides an operator with the capabilities to reach outside the area directly below a rail system. As with all of Knight's servo hoists, this arm allows an operator to precisely locate or float loads in the "Z" direction (vertical axis) with speed, precision, quality, unmatched reliability and repeatability. The KSHEA Series Servo Arm enables the operator to reach beyond the working limits of an overhead rail system within a workstation.

Mechanical Features

- Redundant chain design for safe operation:
 - Load Chain: Supports the load.
 - Safety Chain: Travels with the load chain for safety and redundancy.
- Speeds: Up to **241 ft/min. [74 m/min]**.
- Maximum Lifting Capacity: Up to **750 lbs. [340kg]**.
- Safety Rating of 125%.
- Overhead Carriage-Mounted.
- Fail-Safe Brake.
- Knight's Patented Chain, for longer life.
- Chain Lengths, Unlimited (18 ft. Standard).
- Sealed Worm Style Gearbox.
- H5 Rated (Continuous Duty Cycle).

Software Features

- Programming and Diagnostic Communication Ports.
- Virtual Travel Limits.
- Speed Reduction Zones.
- Impact Limiting.
- Active Dampening.
- Knight's Unique "Float" Mode.
- Programmable Overload Capability.

Electrical Features

- Industry Standard 24 VDC, 2 AMP power is available for custom tooling such as: Clamps, Vacuum Cups, Switches, Proximity Limits, Lights, etc.
- Enable trigger, for quicker response.
- 240 VAC, Single Phase 50/60 Hz.
- Load Sensing, Part Weight and Handle Force.
- I/O Capabilities:
 - (4) Analog Inputs and (4) Analog Outputs
 - (24) Inputs or Outputs, configurable
 - (8) Dedicated Inputs.
 - Expansion I/O: Ethernet, Unlimited.
- LED Status Indicators: Green and Blue Lighted Push Buttons.
- LED Fault Indicator: Illuminated Red Run-Stop Button, Twist to Release.
- Optional: **Remote Pendant** or **Wireless Remote Control**.

KSHEA Series Overhead Carriage Mounted Servo Hoist Arm Specifications

Part Number	Capacity lbs [kg]	Maximum Speed ft/min. [m/min]	Voltage / Phase
KSHEA250S-2401	250 lbs. [113kg]	197 ft/min. [60 m/min]	240 / 1 Phase
KSHEA350S-2401	350 lbs. [159kg]	241 ft/min. [74 m/min]	240 / 1 Phase
KSHEA500S-2401	500 lbs. [227kg]	98 ft/min. [30 m/min]	240 / 1 Phase
KSHEA750S-2401	750 lbs. [340kg]	123 ft/min. [38 m/min]	240 / 1 Phase

Note: Knight's 350 lb. and 750 lb. KSHEA Series arms are considered special ordered items. Contact a Knight representative for more information.

KSHAEA Series

KSHAEA Floor Mounted Articulating Extension Servo Hoist Arm

Knight Global's KSHAEA Series Floor-Mounted Extension Servo Hoist Arm enables an operator to precisely locate or float a load in the "Z" direction (vertical axis) with speed, precision, quality, unmatched reliability and repeatability. The KSHAEA Series Servo Arm allows for non-linear overhead reach that varies depending on the design of the work cell or station. Knight's Floor-Mounted KSHAEA Series is most commonly used when overhead clearances or support structures will not accommodate an overhead rail system.



Mechanical Features

- Redundant chain design for safe operation:
 - Load Chain: Supports the load.
 - Safety Chain: Travels with the load chain for safety and redundancy.
- Speeds: Up to **241 ft/min. [74 m/min]**.
- Maximum Lifting Capacity: Up to **500 lbs. [227kg]**.
- Safety Rating of 125%.
- Floor Mounted Pedestal Heights: 8 ft. [2.4m] - 10 ft. [3.0m].
- Fail-Safe Brake.
- Knight's Patented Chain, for longer life.
- Chain Length, Unlimited (18 ft. Standard).
- Sealed Worm Style Gearbox.

Software Features

- Programming and Diagnostic Communication Ports.
- Virtual Travel Limits.
- Speed Reduction Zones.
- Impact Limiting.
- Active Dampening.
- Knight's Unique "Float" Mode.
- Programmable Overload Capability.

Electrical Features

- Industry Standard 24 VDC, 2 AMP power is available for custom tooling such as: Clamps, Vacuum Cups, Switches, Proximity Limits, Lights, etc.
- Enable trigger, for quicker response.
- 240 VAC, Single Phase 50/60 Hz.
- Load Sensing, Part Weight and Handle Force.
- I/O Capabilities:
 - (4) Analog Inputs and (4) Analog Outputs
 - (24) Inputs or Outputs, configurable
 - (8) Dedicated Inputs.
 - Expansion I/O: Ethernet, Unlimited.
- LED Status Indicators: Green and Blue Lighted Push Buttons.
- LED Fault Indicator: Illuminated Red Run-Stop Button, Twist to Release.
- Optional: **Remote Pendant** or **Wireless Remote Control**.

KSHAEA Series Overhead Carriage Mounted Servo Hoist Arm Specifications

Part Number	Capacity lbs [kg]	Maximum Speed ft/min [m/min]	Voltage / Phase
KSHAEA250S-2401	250 lbs. [113kg]	197 ft/min. [60 m/min]	240 / 1 Phase
KSHAEA350S-2401	350 lbs. [159kg]	241 ft/min. [74 m/min]	240 / 1 Phase
KSHAEA500S-2401	500 lbs. [227kg]	98 ft/min. [30 m/min]	240 / 1 Phase

Note: Knight's 350 lb. and 500 lb. KSHAEA Series arms are considered special ordered items. Contact a Knight representative for more information.

KSHEB Series



KSHEB Overhead Carriage Mounted Articulating Extension Boom Servo Hoist Arm

Knight Global's KSHEB Series Overhead Carriage-Mounted Extension Boom Servo Hoist Arm provides an operator with the capabilities to reach outside the area directly below a rail system and to precisely locate or float loads in the "Z" direction (vertical axis) with speed, precision, quality, unmatched reliability and repeatability. The KSHEB Series Servo Arm allows for overhead reach that varies depending on the design of the work cell or station.

Mechanical Features

- Redundant chain design for safe operation:
 - Load Chain: Supports the load.
 - Safety Chain: Travels with the load chain for safety and redundancy.
- Speeds: Up to **241 ft/min. [74 m/min]**.
- Maximum Lifting Capacity: Up to **1000 lbs. [454kg]**.
- Safety Rating of 125%.
- Overhead Carriage Mounted
- Fail-Safe Brake.
- Knight's Patented Chain, for longer life.
- Chain Length, Unlimited (18 ft. Standard).
- Sealed Worm Style Gearbox.
- H5 Rated (Continuous Duty Cycle).

Software Features

- Programming and Diagnostic Communication Ports.
- Virtual Travel Limits.
- Speed Reduction Zones.
- Impact Limiting.
- Active Dampening.
- Knight's Unique "Float" Mode.
- Programmable Overload Capability.

Electrical Features

- Industry Standard 24 VDC, 2 AMP power is available for custom tooling such as: Clamps, Vacuum Cups, Switches, Proximity Limits, Lights, etc.
- Enable trigger, for quicker response.
- 240 VAC, Single Phase 50/60 Hz.
- Load Sensing, Part Weight and Handle Force.
- I/O Capabilities:
 - (4) Analog Inputs and (4) Analog Outputs
 - (24) Inputs or Outputs, configurable
 - (8) Dedicated Inputs.
 - Expansion I/O: Ethernet, Unlimited.
- LED Status Indicators: Green and Blue Lighted Push Buttons.
- LED Fault Indicator: Illuminated Red Run-Stop Button, Twist to Release.
- Optional: **Remote Pendant** or **Wireless Remote Control**.

KSHEB Series Overhead Carriage Mounted Servo Hoist Arm Specifications

Part Number	Capacity lbs [kg]	Maximum Speed ft/min [m/min]	Voltage / Phase
KSHEB250S-2401	250 lbs. [113kg]	197 ft/min. [60 m/min]	240 / 1 Phase
KSHEB350S-2401	350 lbs. [159kg]	241 ft/min. [74 m/min]	240 / 1 Phase
KSHEB500S-2401	500 lbs. [227kg]	98 ft/min. [30 m/min]	240 / 1 Phase
KSHEB750S-2401	750 lbs. [340kg]	123 ft/min. [38 m/min]	240 / 1 Phase
KSHEB1000S-2401	1000 lbs. [454kg]	82 ft/min. [25 m/min]	240 / 1 Phase

Note: Knight's 350 lb., 750 lb. and 1,000 lb. KSHEB Series arms are considered special ordered items. Contact a Knight representative for more information.

KSHAEB Series

KSHAEB Floor Mounted Articulating Extension Boom Servo Hoist Arm

Knight Global's KSHAEB Series Floor-Mounted Extension Boom Servo Hoist Arm enables an operator to precisely locate or float a load in the "Z" direction (vertical axis) with speed, precision, quality, unmatched reliability and repeatability. The KSHAEB Series Servo Arm allows for non-linear overhead reach that varies depending on the design of the work cell or station. Knight's Floor-Mounted KSHAEB Series is most commonly used when overhead clearances or support structures will not accommodate an overhead rail system.

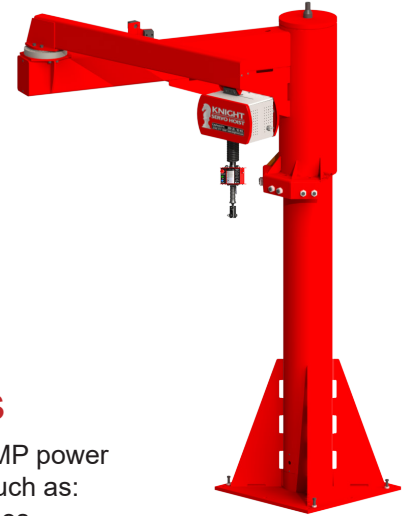

Mechanical Features

- Redundant chain design for safe operation:
 - Load Chain: Supports the load.
 - Safety Chain: Travels with the load chain for safety and redundancy.
- Speeds: Up to **241 ft/min. [60 m/min]**.
- Maximum Lifting Capacity: Up to **1,000 lbs. [453kg]**.
- Safety Rating of 125%.
- Floor Mounted.
- Fail-Safe Brake.
- Knight's Patented Chain, for longer life.
- Chain Length, Unlimited (18 ft. Standard).
- Sealed Worm Style Gearbox.
- H5 Rated (Continuous Duty Cycle).

Electrical Features

- Industry Standard 24 VDC, 2 AMP power is available for custom tooling such as: Clamps, Vacuum Cups, Switches, Proximity Limits, Lights, etc.
- Enable trigger, for quicker response.
- 240 VAC, Single Phase 50/60 Hz.
- Load Sensing, Part Weight and Handle Force.
- I/O Capabilities:
 - (4) Analog Inputs and (4) Analog Outputs
 - (24) Inputs or Outputs, configurable
 - (8) Dedicated Inputs.
 - Expansion I/O: Ethernet, Unlimited.
- LED Status Indicators: Green and Blue Lighted Push Buttons.
- LED Fault Indicator: Illuminated Red Run-Stop Button, Twist to Release.
- Optional: **Remote Pendant** or **Wireless Remote Control**.

Software Features

- Programming and Diagnostic Communication Ports.
- Virtual Travel Limits.
- Speed Reduction Zones.
- Impact Limiting.
- Active Dampening.
- Knight's Unique "Float" Mode.
- Programmable Overload Capability.

KSHAEB Series Overhead Carriage Mounted Servo Hoist Arm Specifications

Part Number	Capacity lbs [kg]	Maximum Speed [fpm/mpm]	Voltage / Phase
KSHAEB250S-2401	250 lbs. [113kg]	197 ft/min. [60 m/min]	240 / 1 Phase
KSHAEB350S-2401	350 lbs. [159kg]	241 ft/min. [74 m/min]	240 / 1 Phase
KSHAEB500S-2401	500 lbs. [227kg]	98 ft/min. [30 m/min]	240 / 1 Phase
KSHAEB750S-2401	750 lbs. [340kg]	123 ft/min. [38 m/min]	240 / 1 Phase
KSHAEB1000S-2401	1000 lbs. [454kg]	82 ft/min. [25 m/min]	240 / 1 Phase

Note: Knight's 350 lb., 750 lb. and 1,000 lb. KSHEB Series arms are considered special ordered items. Contact a Knight representative for more information.



KSHVA Overhead Carriage Mounted Vertical Articulating Servo Hoist Arm

Knight Global's KSHVA Series Overhead Carriage-Mounted Vertical Servo Hoist Arm enables an operator to reach low and overhead work areas to manipulate heavy loads in a confined work cell. Also, the system can precisely locate or float that load in the "Z" direction (vertical axis) with speed, precision, quality, unmatched reliability and repeatability. The KSHVA Series Servo Arm creates a stable lifting platform, eliminating the yarding and swinging of the free hanging chain or cable of other systems.

Mechanical Features

- Redundant chain design for safe operation:
 - Load Chain: Supports the load.
 - Safety Chain: Travels with the load chain for safety and redundancy.
- Speeds: Up to **241 ft/min. [74m/min]**.
- Maximum Lifting Capacity: Up to **1,000 lbs. [454kg]**.
- Safety Rating of 125%.
- Overhead Carriage Mounted.
- Fail-Safe Brake.
- Knight's Patented Chain, for longer life.
- Chain Length, Unlimited (18 ft. Standard).
- Sealed Worm Style Gearbox.
- H5 Rated (Continuous Duty Cycle).

Software Features

- Programming and Diagnostic Communication Ports.
- Virtual Travel Limits.
- Speed Reduction Zones.
- Impact Limiting.
- Active Dampening.
- Knight's Unique "Float" Mode.
- Programmable Overload Capability.

Electrical Features

- Industry Standard 24 VDC, 2 AMP power is available for custom tooling such as: Clamps, Vacuum Cups, Switches, Proximity Limits, Lights, etc.
- Enable trigger, for quicker response.
- 240 VAC, Single Phase 50/60 Hz.
- Load Sensing, Part Weight and Handle Force.
- I/O Capabilities:
 - (4) Analog Inputs and (4) Analog Outputs
 - (24) Inputs or Outputs, configurable
 - (8) Dedicated Inputs.
 - Expansion I/O: Ethernet, Unlimited.
- LED Status Indicators: Green and Blue Lighted Push Buttons.
- LED Fault Indicator: Illuminated Red Run-Stop Button, Twill to Release.
- Optional: **Remote Pendant** or **Wireless Remote Control**.

KSHVA Series Overhead Carriage Mounted Servo Hoist Arm Specifications

Part Number	Capacity lbs [kg]	Maximum Speed ft/min. [m/min]	Voltage / Phase
KSHVA250S-2401	250 lbs. [113kg]	197 ft/min. [60 m/min]	240 / 1 Phase
KSHVA350S-2401	350 lbs. [159kg]	241 ft/min. [74 m/min]	240 / 1 Phase
KSHVA750S-2401	750 lbs. [340kg]	123 ft/min. [38 m/min]	240 / 1 Phase
KSHVA1000S-2401	1000 lbs. [454kg]	82 ft/min. [25 m/min]	240 / 1 Phase

Note: All capacities exclude the weight of the jib and the boom. Knight's 350 lb., 750 lb. and 1,000 lb. KSHVA Series arms are considered special ordered items. Contact a Knight representative for more information.

KSHVAA Series

Knight KSHVAA Floor-Mounted Articulating Servo Hoist Arm

Knight Global's KSHVAA Series Floor-Mounted Vertical Servo Hoist Arm enables an operator to reach low and overhead work areas to manipulate heavy loads in a confined work cell. Also, the system can precisely locate or float that load in the "Z" direction (vertical axis) with speed, precision, quality, unmatched reliability and repeatability. The KSHVAA Series Servo Arm creates a stable lifting platform, eliminating the yarding and swinging of the free hanging chain or cable of other systems.

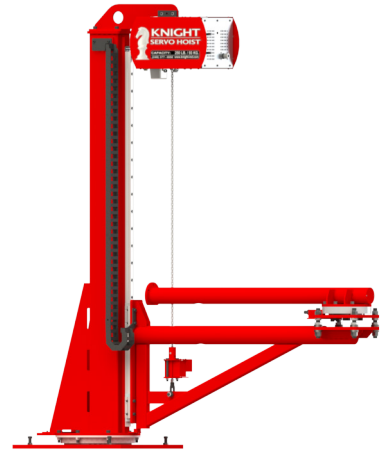

Mechanical Features

- Redundant chain design for safe operation:
 - Load Chain: Supports the load.
 - Safety Chain: Travels with the load chain for safety and redundancy.
- Speeds: Up to **241 ft/min. [74m/min]**.
- Maximum Lifting Capacity: Up to **1,000 lbs. [453kg]**.
- Safety Rating of 125%.
- Floor-Mounted.
- Fail-Safe Brake.
- Knight's Patented Chain, for longer life.
- Chain Length, Unlimited (18 ft. Standard).
- Sealed Worm Style Gearbox.
- H5 Rated (Continuous Duty Cycle).

Software Features

- Programming and Diagnostic Communication Ports.
- Virtual Travel Limits.
- Speed Reduction Zones.
- Impact Limiting.
- Active Dampening.
- Knight's Unique "Float" Mode.
- Programmable Overload Capability.

Electrical Features

- Industry Standard 24 VDC, 2 AMP power is available for custom tooling such as: Clamps, Vacuum Cups, Switches, Proximity Limits, Lights, etc.
- Enable trigger, for quicker response.
- 240 VAC, Single Phase 50/60 Hz.
- Load Sensing, Part Weight and Handle Force.
- I/O Capabilities:
 - (4) Analog Inputs and (4) Analog Outputs
 - (24) Inputs or Outputs, configurable
 - (8) Dedicated Inputs.
 - Expansion I/O: Ethernet, Unlimited.
- LED Status Indicators: Green and Blue Lighted Push Buttons.
- LED Fault Indicator: Illuminated Red Run-Stop Button, Twist to Release.
- Optional: **Remote Pendant** or **Wireless Remote Control**.





KSHVAA Series Overhead Carriage Mounted Servo Hoist Arm Specifications

Part Number	Capacity lbs [kg]	Maximum Speed ft/min. [m/min]	Voltage / Phase
KSHVAAS-250-2401	250 lbs. [113kg]	197 ft/min. [60 m/min]	240 / 1 Phase
KSHVAAS-350-2401	350 lbs. [159kg]	241 ft/min. [74 m/min]	240 / 1 Phase
KSHVAAS-750-2401	750 lbs. [340kg]	123 ft/min. [38 m/min]	240 / 1 Phase
KSHVAAS-1000-2401	1000 lbs. [453kg]	82.02 ft/min. [25 m/min]	240 / 1 Phase





Note: All capacities exclude the weight of the jib and the boom. Knight's 350 lb., 750 lb. and 1,000 lb. KSHVAA Series arms are considered special ordered items. Contact a Knight representative for more information.

Servo Arm Accessories

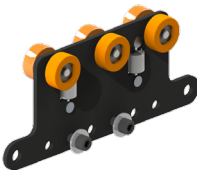

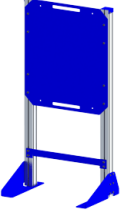

Knight Global Servo Hoist Accessories contain a wide variety of accessories that include; Trolleys for Rail Systems, Air Balancer Pulleys, Hooks and Safety Cable Kits.

KDSA1010 Servo Hoist Chain Replacement Kit	KDSA1011 Servo Hoist Chain Replacement Kit	EBD1547 Servo Hoist Roller Chain	KSAD1022 Swivel Hook with Eye	KSAA1001 & KSAA1002 Quick Connect/ Disconnect
 <ul style="list-style-type: none"> • Knight's unique 4mm chain. • Servo Hoist Model: KSH250S & 500S Series. • Chain Length: 18 ft. [549 cm]. • Maximum Working Load: 500 lbs. [227 kg]. 	 <ul style="list-style-type: none"> • Knight's unique 5mm chain. • Servo Hoist Model: KSH350S-2000S Series. • Chain Length: 12 ft. [366 cm]. • Maximum Working Load: 2,000 lbs. [907kg]. 	 <ul style="list-style-type: none"> • Standard Series Double Strand ANSI 50-2 Rolle Chain. • Avg. Tensile Strength: 12,200 lbs [5,534kg]. • Maximum Working Load: 2,000 lbs [907kg]. 	 <ul style="list-style-type: none"> • Max. Capacity: Up to 3,200 lbs. [1,451kg]. • Positive Lock Latch is Self-Locking when hook is loaded. • Rated for both Wire Rope and use with Grade 80/100 Chain. 	 <ul style="list-style-type: none"> • Max. Load Capacity: Up to 2,000 lbs. [907kg]. • KSAA1001- 16mm to 7/8 in. adapter. • KSAA1002- 20mm to 1.25 in. adapter.





KSAA1004 Shackle	KSAA1007 Swivel Hook Shackle	KSAA1048 Load Trolley	KSAA1059 Load Trolley	KSAA1050 Load Trolley
 <ul style="list-style-type: none"> • Secures fixtures or loads in-line with chain. • Maximum Capacity: Up to 1,000 lbs [453kg]. 	 <ul style="list-style-type: none"> • Max. Capacity: Up to 1,000 lbs. [454kg]. • Larger Connection Opening. 	 <ul style="list-style-type: none"> • Transfers Loads along the horizontal axis and suspends Servo Hoists from RAD4110 rail. • Max. Capacity: Up to 900 lbs. [408kg]. 	 <ul style="list-style-type: none"> • Transfers Loads along the horizontal axis and suspends Servo Hoists from RAD6110 rail. • Max. Capacity: Up to 1,600 lbs. [725kg]. 	 <ul style="list-style-type: none"> • Transfers Loads along the horizontal axis and suspend Servo Hoists from RAD7510 rail. • Max. Capacity: Up to 2,500 lbs. [1,134kg].



KCA1040 Series Electrical Coiled Cable	KCA1041 Series Electrical Straight Cable	4-Pin Micro Switch Cable	8-Pin Micro Switch Cable	KCA1001 Electrical Disconnect Enclosure Stand
 <ul style="list-style-type: none"> • Connects a Servo Hoist to a load monitoring module by wrapping itself around the Servo Chain. • 90 Degree Male to Female Connectors. 	 <ul style="list-style-type: none"> • Connects a separate control handle pendant to Servo Hoists. • 90 Degree Male to Female Connectors. 	 <ul style="list-style-type: none"> • 4-Pin Micro DC Single Key. • Available with Straight or Right Angle Connector Ends. 	 <ul style="list-style-type: none"> • 8-Pin Micro DC Single Key. • Available with Straight or Right Angle Connector Ends. 	 <ul style="list-style-type: none"> • Mounts enclosures at an ergonomically correct height. • Provides mounting surface for enclosures in open workstation environments.

Servo Arm Accessories (Cont.)

KSAA1063 Precision Roller Chain Wear Gauge	KCA1018 3KVA Electrical Disconnect Enclosure	KCA1055 5KVA Electrical Disconnect Enclosure	KCA1056 Dual 5KVA Elec. Disconnect Enclosure	EBA1289 7.5 KVA Electrical Disconnect Enclosure
 <ul style="list-style-type: none"> • Used to measure the wear on Servo Arm roller chains. 	 <ul style="list-style-type: none"> • Used with: KSH250S, 350S, 500S, 750S and 1000S Servo Hoists. • Flange disconnect. 	 <ul style="list-style-type: none"> • Used with: KSHXY, KSHXZ, KSHTCDM and KSHXYZ Servo Tractors and Hoists. • Step down from 480VAC to 240VAC Flange disconnect. 	 <ul style="list-style-type: none"> • Used with: KSHXY, KSHXZ, KSHTC and KSHXYZ Servo Tractors and Hoists. • Step down from 480VAC to 240VAC Flange disconnect. • Provides disconnection point for two Knight Global systems. 	 <ul style="list-style-type: none"> • Used with: KSHXXYZ and KSHXYZR Servo Tractor Systems. • (2) Flange disconnect

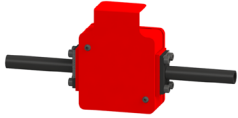
Servo Arm Controls

EPDA9600 Two-Speed Control Handle	EPDTA9600 Two-Speed Control Handle w/ Trigger	KCA1033 Two-Speed Control Handle w/ Operator Control Interface	KLCA1000 Inline Control Handle w/ Trigger	KCA1071 Load Cell Fixture Handle
 <ul style="list-style-type: none"> • May be mounted remotely from the end effector. • Custom lever markings, specify when ordering. • Different Call-out Languages Available. 	 <ul style="list-style-type: none"> • Various Mounting Options. • UL Listed, CE Approved. • Optional Color-Coded Thumb Levers. 	 <ul style="list-style-type: none"> • Allows for 2-Speed Operation. • Operator Control Interface • Safety Run-Stop Button. • Illuminated Blue Float and Green Lift Push Buttons. • Ethernet Programming Port. 	 <ul style="list-style-type: none"> • (LMM) Load Monitoring Module. • Illuminated Blue/ Green Push Buttons. • Illuminated Red Run-Stop Button. • Ethernet Programming Port. 	 <ul style="list-style-type: none"> • Attaches directly to fixture. • Load Responsive Handling. • Handle Force Response: Less than 1.5 lbs. [0.68kg].

KCA1002 Load Monitoring Module w/ O.C.I.	KCA1004 Load Monitoring Module w/ Pass Through	KCA1004 / KCA1005 / KCA1006 Wireless Remote
 <ul style="list-style-type: none"> • Used in conjunction with the Dual Speed Handle Pendant or Fixture Handle. • (1) 6-Pin M12 Receptacle for Fixture Handle. • Ethernet Programming Port. 	 <ul style="list-style-type: none"> • Used in conjunction with the Dual Speed Remote Pendant, Fixture Handle or remote OCI module. • (2) 4-Pin receptacles for inputs. • Ethernet Programming Port. 	 <ul style="list-style-type: none"> • Wireless Signal: Up to 900 ft. [300m]. • Ultra-Durable Nylon and Fiberglass Composite Enclosures. • Up to (8) Eight Function/ Operation Buttons.