



TRA5005 Bridge Tow Bar Assembly

Knight Global's TRA5005 Bridge Tow Bar Assemblies are used in conjunction with Knight's TRA5500 Series Air Tractor. The TRA5005 Tow Bar Assembly allows for Knight Air Tractors to tow the overhead rail bridges without causing the bridges to skew.

Knight's TRA5005-6110 runs in RAD6110 Series Rail and Knight's TRA5005-7510 runs in RAD7510 Series Rail.

TRA5005-6110

TRA5005-7510

MAX. TOWING CAPACITY: 3,000 lbs [1,360kg].

TRA5005 Features

- Used in conjunction with the TRA5500 Air Tractor to prevent a bridge or runway from skewing.
- TRA5005-6110 runs in RAD6110 Series Rail.
- TRA5005-7510 runs in RAD7510 Series Rail.
- Tows Knight's RAD4110 / 6110 / 7510 bridges.
- Adjustable Spans.
- Easy Assembly and Installation.
- Can be configured for dual or tri-runway systems.

Dual-Runway Configuration

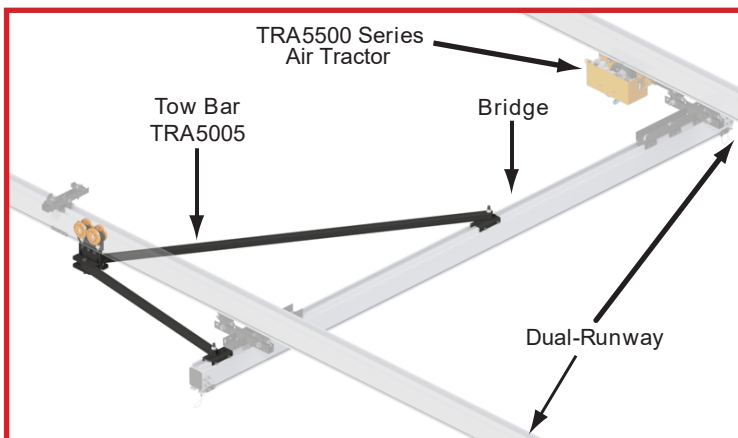

Tri-Runway Configuration

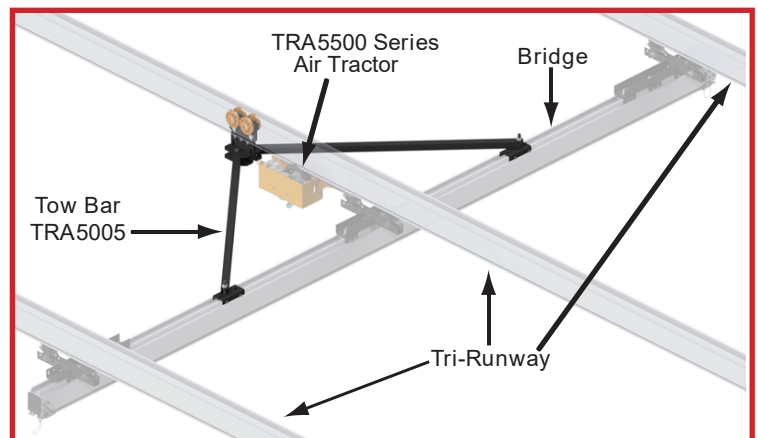

For more information, please contact a Knight Global representative.



TRA5005 Bridge Tow Bar Assembly

Dual Runway

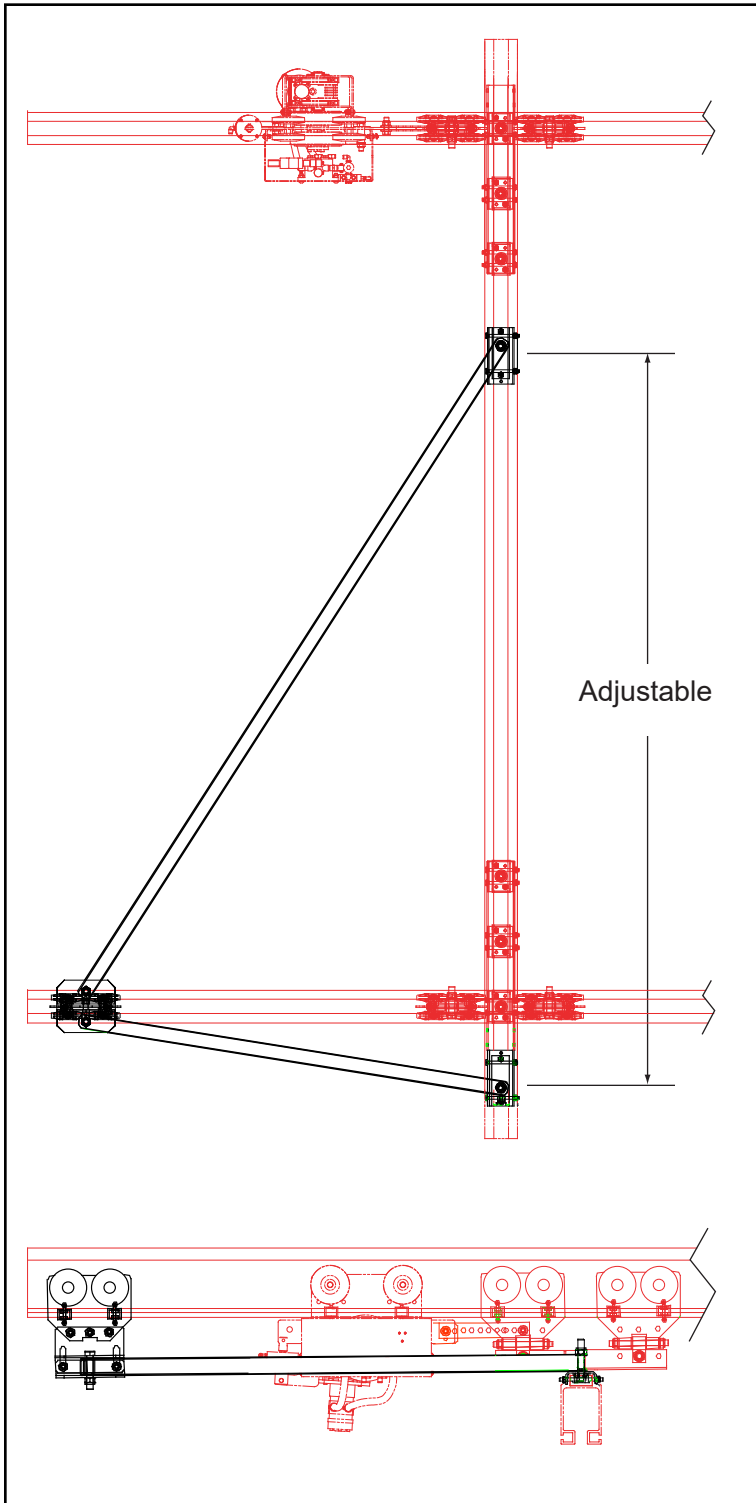

Tri-Runway

