

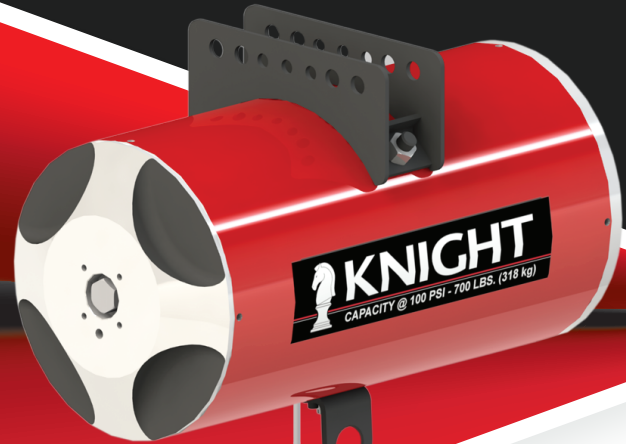

KNIGHT GLOBAL

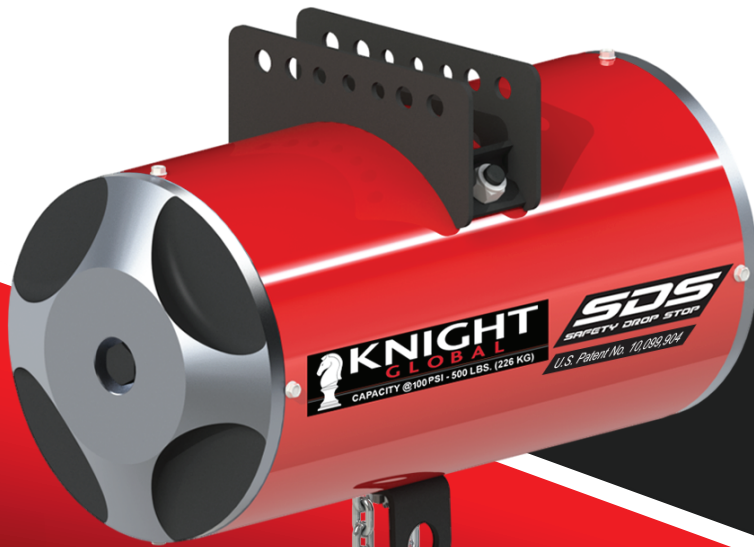

Pneumatic Balancer Series

rev.20250212

Introduction

Overview	1
--------------------	---

Balancer Series

KBCS Safety Drop Stop Series	2
KBA Cable Series	3
KBC Chain Series	4
DKBC Dual Drum Series	5
KBA/KBC External Retract Series	6
KBA/KBC Limit Switch Series	7
RKBA Reeved Cable Series	8
RKBC Reeved Chain Series	9
TKBA Tandem Cable Series	10
TKBC Tandem Chain Series	11
KEAA2000 Dual Bridge Extension Arm Series	12
KEAA2500 Single Bridge Extension Arm Series	14
Balancer Controls	16
Balancer Accessories	18

Knight Global | Warranty Information

Knight warrants that its products and parts shall meet all applicable specifications, performance requirements, and be free from defects in material and workmanship for one year, (Servo Systems for two years, Pneumatic Lift Tables for 5 years), from the date of invoice, unless otherwise noted. One exclusion would include any purchased components not manufactured by Knight and their specific individual warranties. Paint defects, scratches and marring from shipping are also excluded.

This warranty shall not cover the failure or defective operation caused by inadequate training provided by customer regarding the operation and / or maintenance of the tool, misuse, negligence, misadjustment, or any alteration not approved by Knight. Knight's obligation is limited to the replacement or repair of Knight's products at a location designated by Knight. Buyer is responsible for all associated internal removal and reinstallation costs as well as freight charges to and from Knight Industries. Knight's maximum liability shall not in any case exceed the contract price for the products claimed to be defective.

Any field modification made to Knight Products or Systems without the written authorization by Knight Global shall void Knight's warranty obligation.

Knight warrants the Servo Hoist, Arms, and Tractors to be free from defects in material or workmanship for a period of two years or 6000 hours use from the date of shipment.

Knight Distributors/ Agents are not authorized to circumvent or change any of these terms and or conditions of this warranty unless prior approval is received in writing by Knight Global Management. Verbal statements made by Knight Distributors/ Agents do not constitute warranties.

On a design and build job, the customer is the owner of the equipment once they authorize shipment. The purchased equipment can not be returned for reimbursement or credit.

DISCLAIMERS: OTHER THAN AS SET FORTH HEREIN, NO OTHER EXPRESSED WARRANTIES, AND NO IMPLIED WARRANTIES, ORAL AND WRITTEN, INCLUDING BUT NOT LIMITED TO THE WARRANTIES OF MERCHANTABILITY OR FITNESS FOR A PARTICULAR PURPOSE, ARE MADE BY KNIGHT GLOBAL WITH RESPECT TO ITS PRODUCTS AND ALL SUCH WARRANTIES ARE HEREBY SPECIFICALLY DISCLAIMED.

KNIGHT GLOBAL SHALL NOT BE LIABLE UNDER ANY CIRCUMSTANCES FOR ANY INCIDENTAL, SPECIAL AND/OR CONSEQUENTIAL DAMAGES WHATSOEVER, WHETHER OR NOT FORESEEABLE, INCLUDING BUT NOT LIMITED TO DAMAGES FOR LOST PROFITS AND ALL SUCH INCIDENTAL, SPECIAL AND/OR CONSEQUENTIAL DAMAGES ARE HEREBY ALSO SPECIFICALLY DISCLAIMED.

KNIGHT GLOBAL WILL NOT BE LIABLE FOR ANY LOSS, INJURY OR DAMAGE TO PERSONS OR PROPERTY, NOR FOR DAMAGES OF ANY KIND RESULTING FROM FAILURE OR DEFECTIVE OPERATION OF ANY MATERIALS OR EQUIPMENT FURNISHED HEREUNDER.

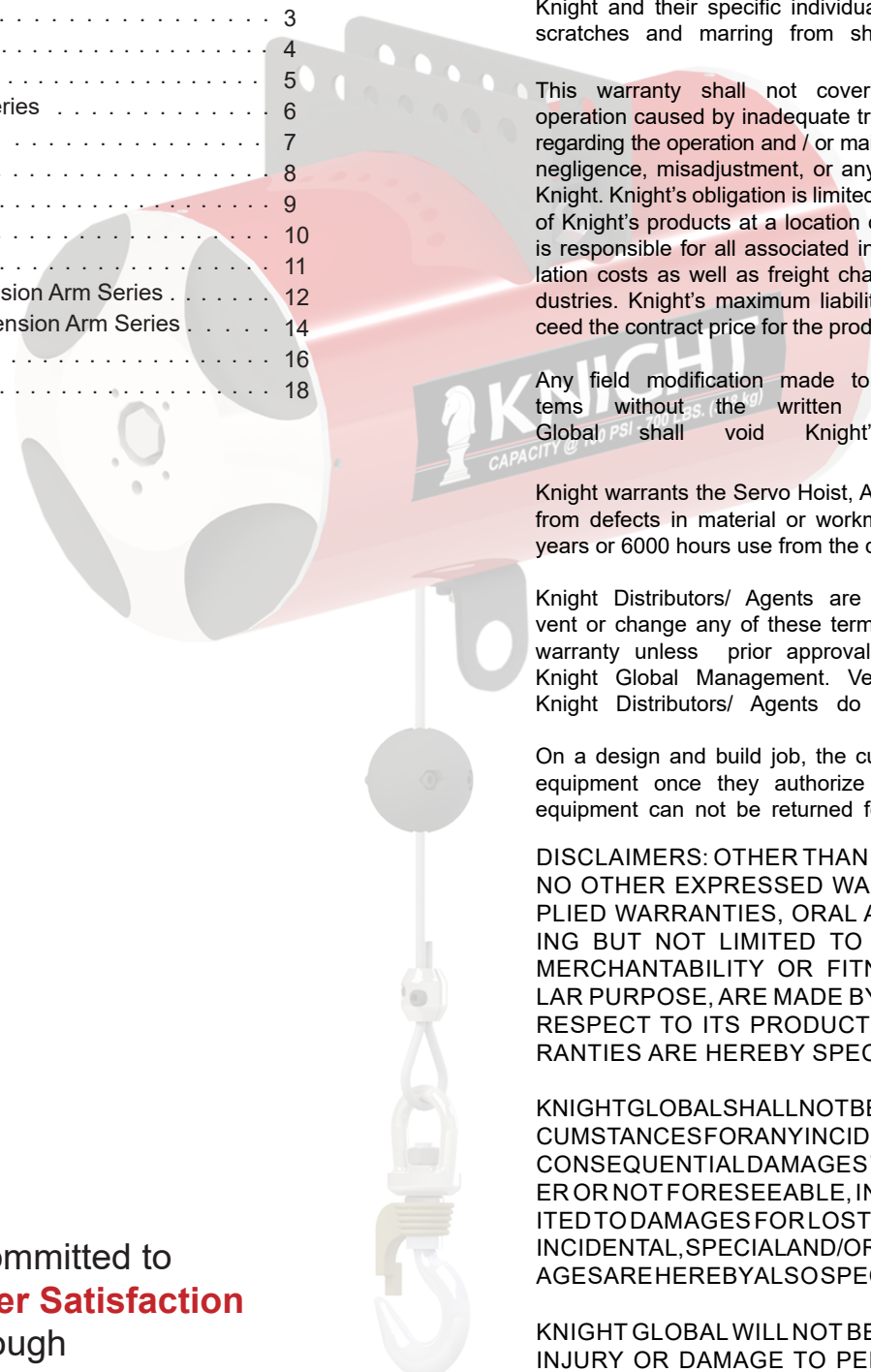

We are committed to
Total Customer Satisfaction
through
QUALITY, RELIABILITY and
EMPLOYEE INVOLVEMENT.

Overview

Knight Pneumatic Air Balancers

Knight Global Pneumatic/Air Balancers are designed to assist in transferring loads ergonomically using a variety of Up/Down pendants or Balance “Float” Control Options.

Air Balancers provide superior control over standard air hoists when it comes to locating and positioning loads. The operator can take their hand off the pendant and actually “float” the part into position. The sensation is one of part weightlessness. Knight Air Balancer speeds when compared to a traditional hoist are greater.



Safety Drop Stop Series



Cable Series

Chain Series

Pneumatic Air Balancer Series

The pneumatic air balancer series is offered in various configurations and capacities to accommodate your specific applicational needs.

Features and Benefits:

- CE Compliant **
- Safety Drop Stop Chain
- Hands-Free Operation
- Standard “Float” Mode
- Internal Centrifugal Retract Control.
- Requires Non-Lubricated Clean/Dry Air.
- Multiple configurations.

Options and Accessories:

- Optional External Retract Controls.
- Optional Limit Switch Controls.
- Optional High Relieving and Feathertouch Controls.
- Optional Up/Down Controls.
- Multiple Suspension Kits available.

** CE compliance is not a standard feature on Knight Global Pneumatic Balancers. Please contact us for more details.

Model	Style	Max. Capacity (lbs)
KBCS	Safety Drop Stop Chain	Up to 700 lbs.
KBA	Cable	Up to 700 lbs.
KBC	Chain	Up to 700 lbs.
DKBCS	Dual Drum SDS	Up to 700 lbs.
KBA-EX	Cable (External Retract)	Up to 700 lbs.
KBC-EX	Chain (External Retract)	Up to 700 lbs.
KBA-LS	Cable (Limit Switch)	Up to 700 lbs.
KBC-LS	Chain (Limit Switch)	Up to 700 lbs.
RKBA	Reeved Cable	Up to 1,400 lbs.
RKBC	Reeved Chain	Up to 1,400 lbs.
TKBA	Tandem Cable	Up to 1,400 lbs.
TKBC	Tandem Chain	Up to 1,400 lbs.
KEAA2000	Single Bridge Extension Arm w/ Balancer	Up to 700 lbs.
KEAA2500	Dual Bridge Extension Arm w/ Balancer	Up to 700 lbs.

Cable Pneumatic Balancers are commonly used when lower weight parts are required to be floated into position.

Chain Pneumatic Balancers are recommended when balancing weights in excess of 350 lbs or when high cycle times are required.

KBCS Series

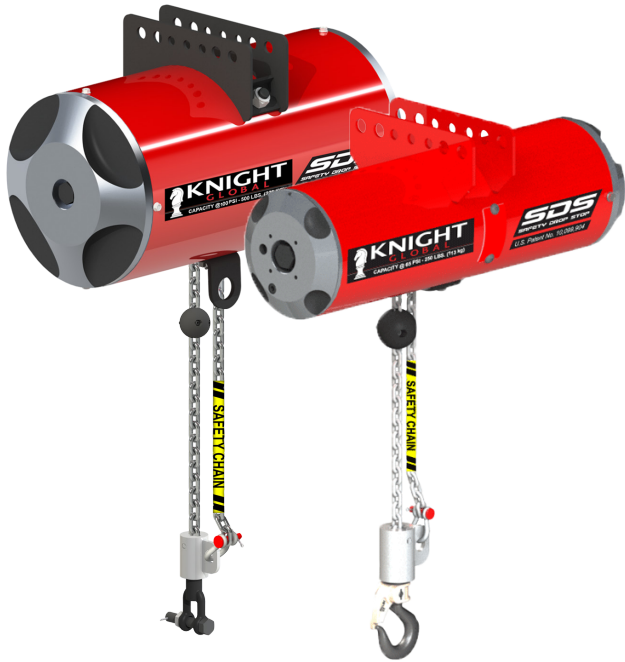

Safety Drop Stop “SDS” Chain Balancer

Knight Global Pneumatic/Air Balancers are designed to assist in transferring loads ergonomically using a variety of Up/Down pendants or Balance “Float” Control Options.

Air Balancers provide superior control over standard air hoists when it comes to locating and positioning loads. The operator can take their hand off the pendant and actually “float” the part into position. The sensation is one of part weightlessness. Knight Air Balancer speeds when compared to a traditional hoist are greater.

KBCS SERIES CAPACITIES

Model	Rated Capacity lbs. [kg]	Maximum Travel in. [mm]
KBC250S-054	250 lbs [113kg]	54 in [1371mm]
KBC450S-052	450 lbs [204kg]	52 in [1321mm]
KBC500S-084	500 lbs [227kg]	84 in [2133mm]
KBC700S-052	700 lbs [318kg]	52 in [1321mm]

Features

- CE Compliant. **
- Redundant chain design for safe operation:
 - Load Chain: Carries the load.
 - Safety Chain: Rides along for redundancy.
- Hands-Free Operation.
- Standard “Float” Mode.
- Internal Centrifugal Retract Control.
- Requires Non-Lubricated Clean/Dry Air.
- Max. Balancing Capacity: Up to **700 lbs. [317kg]**.
- Standard Travel: Up to **84 in. [2133mm]**.

** CE compliance is not a standard feature on Knight Global Pneumatic Balancers. Please contact us for more details.

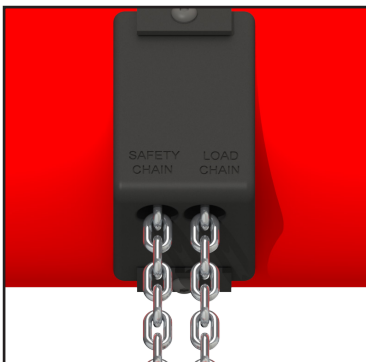

Benefits

- Optional External Retract Controls. (EX models)
- Optional High Relieving and Feathertouch Controls.
- Multiple Suspension Kits Available.

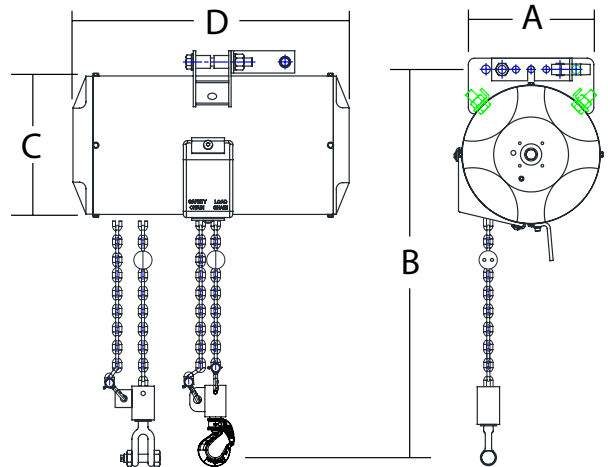

Part Number	Capacity lbs. [kg.]	Travel in. [mm.]	(A) in. [mm.]	(B) (min.) in. [mm.]	(C) in. [mm.]	(D) in. [mm.]	Product Weight lbs. [kg.]
KBC250S-054	250 [113]	54 [1,371]	8 1/2 [215]	18 1/4 [463]	6 1/2 [165]	20 3/4 [527]	63 [28]
KBC450S-052	450 [204]	52 [1,321]	8 1/2 [215]	22 1/2 [571]	6 1/2 [165]	20 3/4 [527]	81 [37]
KBC500S-084	500 [227]	84 [2,133]	9 3/4 [248]	19 3/4 [502]	10 3/4 [273]	21 13/16 [554]	115 [52]
KBC700S-052	700 [318]	52 [1,321]	9 3/4 [248]	19 3/4 [502]	10 3/4 [273]	21 13/16 [554]	95 [43]

KBA Cable Series

Knight KBA Cable Series

Knight Global's KBA Series Cable Air Balancers are used in applications where a "float" condition is beneficial. Float allows for the hands-free final positioning of an object. The up/ down speed of an air balancer is quicker when compared to a hoist and allows for a "feathering" operation when locating the load.



Features

- CE Compliant. **
- Hands-Free Operation.
- Standard "Float" Mode.
- Internal Centrifugal Retract Control.
- Requires Non-Lubricated Clean/Dry Air.
- Max. Balancing Capacity:
Up to **700 lbs. [317kg]**.
- Standard Travel: Up to **110 in. [2794mm]**.

** CE compliance is not a standard feature on Knight Global Pneumatic Balancers. Please contact us for more details.

Benefits

- Lighter than chain.
- Stroke is longer (**Certain Models**).
- Optional External Retract Controls. (**EX models**)
- Optional High Relieving and Feathertouch Controls.
- Optional Tandem, Reeved, Tandem Reeved Series.
- Tool-Bench sized applications.
- Multiple Suspension Kits Available.

KBA SERIES CAPACITIES

Model	Rated Capacity lbs. [kg]	Maximum Travel in. [mm]
KBA150-076	150 lbs [68kg]	76 in [1930mm]
KBA225-073	225 lbs [102kg]	73 in [1854mm]
KBA225-110	225 lbs [102kg]	110 in [2794mm]
KBA350-073	350 lbs [159kg]	73 in [1854mm]
KBA450-054	450 lbs [204kg]	54 in [1371mm]
KBA500-080	500 lbs [227kg]	80 in [2032mm]
KBA700-054	700 lbs [318kg]	54 in [1371mm]

When specifying an Air Balancer, it is recommended to use 80% of the rated load to determine your load capacity. This approach compensates for the normal fluctuations within the plant compressed air supply. Balancers are rated at **100 psi [6.8bar]** therefore use the following example to calculate exact load capability.

Formula for Air Balancer sizing:

Example: plant air 80 psi, 350 air balancer, 80% load capability
 $(0.80 \text{ air supply} \times 350 \text{ lbs.} = 280 \times .80 = 224 \text{ lbs. load capability})$.

KBA SERIES SPECIFICATIONS

Model	(A) in. [mm]	(B) (min.) in. [mm]	(C) in. [mm]	(D) in. [mm]	Product Weight lbs [kg]
KBA150-076	8 1/2 [216]	16 1/2 [419]	6 1/2 [165]	15 1/2 [394]	49 [22]
KBA225-073	8 1/2 [216]	18 1/4 [463]	8 3/4 [222]	16 3/4 [426]	61 [28]
KBA225-110	9 3/4 [248]	21 [533]	10 3/4 [273]	16 3/4 [426]	88 [40]
KBA350-073	9 3/4 [248]	21 [533]	10 3/4 [273]	16 3/4 [426]	76 [34]
KBA450-054	8 1/2 [216]	21 5/16 [541]	8 5/8 [219]	20 13/16 [526]	72 [33]
KBA500-080	9 3/4 [248]	21 [533]	10 3/4 [273]	21 13/16 [554]	112 [51]
KBA700-054	9 3/4 [248]	21 [533]	10 3/4 [273]	21 13/16 [554]	91 [41]

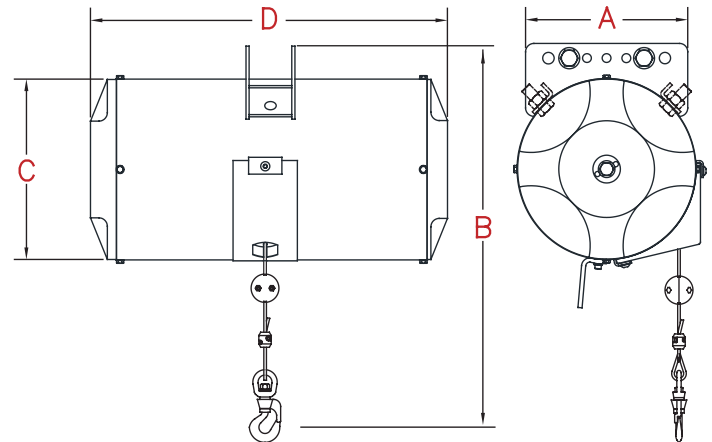

KBC Chain Series



Knight KBC Chain Series

Knight Global's KBC Series Chain Air Balancers are primarily designed for weights exceeding **350 lbs. [159kg]** or for high cycle applications. Air Balancers are used in applications where a "float" condition is beneficial. Float allows for the hands-free final positioning of an object. The up/ down speed of an Air balancer is quicker when compared to a hoist and allows for a "feathering" operation when locating the load.

Features

- CE Compliant. **
- Hands-Free Operation.
- Standard "Float" Mode.
- Internal Centrifugal Retract Control.
- Requires Non-Lubricated Clean/Dry Air.
- Max. Balancing Capacity:
Up to **700 lbs. [317kg]**.
- Standard Travel: Up to **110 in. [2794mm]**.

Benefits

- Optional External Retract Controls. (EX models)
- Optional High Relieving and Feathertouch Controls.
- Optional Tandem, Reeved Series.
- Multiple Suspension Kits Available.
- With Heavier Loads, Cable has a Greater Chance of "Bird-Caging" or Pre-Mature Wearing.

** CE compliance is not a standard feature on Knight Global Pneumatic Balancers. Please contact us for more details.

KBC SERIES CAPACITIES

Model	Rated Capacity lbs. [kg]	Maximum Travel in. [mm]
KBC150-070	150 lbs [68kg]	70 in [1778mm]
KBC200-110	200 lbs [91kg]	110 in [2794mm]
KBC225-067	225 lbs [102kg]	67 in [1701mm]
KBC350-067	350 lbs [159kg]	67 in [1701mm]
KBC500-080	500 lbs [227kg]	80 in [2032mm]
KBC700-052	700 lbs [318kg]	52 in [1320mm]

When specifying an Air Balancer, it is recommended to use 80% of the rated load to determine your load capacity. This approach compensates for the normal fluctuations within the plant compressed air supply. Balancers are rated at **100 psi [6.8bar]** therefore use the following example to calculate exact load capability.

Formula for Air Balancer sizing:

Example: plant air 80 psi, 350 air balancer, 80% load capability
 $(0.80 \text{ air supply} \times 350 \text{ lbs.} = 280 \times .80 = 224 \text{ lbs. load capability})$.

KBC SERIES SPECIFICATIONS

Model	(A) in. [mm]	(B) (min.) in. [mm]	(C) in. [mm]	(D) in. [mm]	Product Weight lbs [kg]
KBC150-070	8 1/2 [216]	16 1/2 [419]	6 1/2 [165]	15 1/2 [394]	51 [23]
KBC200-110	10 3/4 [273]	19 3/4 [521]	10 3/4 [273]	16 1/2 [419]	93 [42]
KBC225-067	8 3/4 [223]	18 1/2 [470]	8 3/4 [222]	16 3/4 [426]	63 [28]
KBC350-067	9 3/4 [248]	19 3/4 [502]	10 3/4 [273]	16 1/2 [419]	78 [35]
KBC500-080	9 3/4 [248]	19 3/4 [502]	10 3/4 [273]	21 13/16 [554]	115 [52]
KBC700-052	9 3/4 [248]	19 3/4 [502]	10 3/4 [273]	21 13/16 [554]	95 [43]

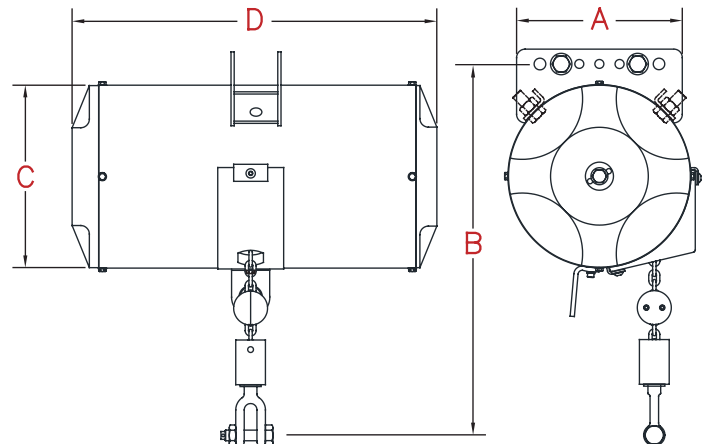

Dual Drum “SDS” Series

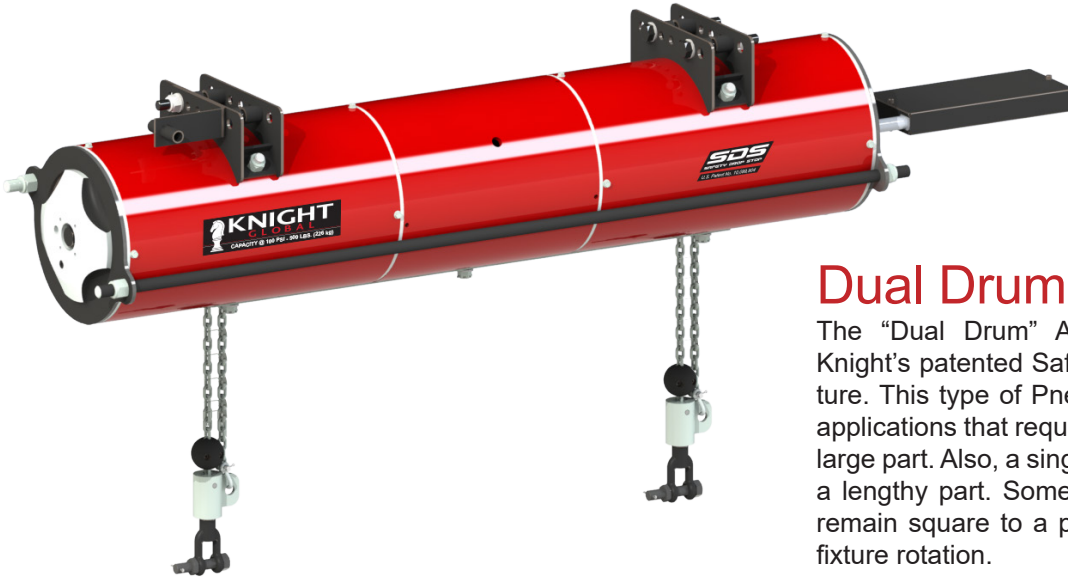

Dual Drum “SDS” Balancer

The “Dual Drum” Air Balancer comes equipped with Knight’s patented Safety Drop Stop “SDS” dual chain feature. This type of Pneumatic Balancer is typically used in applications that require the manipulation of an unwieldy or large part. Also, a single suspension point may not stabilize a lengthy part. Some applications require that the fixture remain square to a part and (2) two hook points prevent fixture rotation.

Having two synchronized spools inside one housing, the Dual Drum Balancer offers added balance to awkwardly weighted or shaped loads by lifting and balancing from two suspension points.

This balancer comes equipped with an external retract control. Limit switches can also be ordered as an option.*

DKBCS SERIES CAPACITIES

Model	Rated Capacity lbs. [kg]	Maximum Travel in. [mm]
DKBC500S	500 lbs [227kg]	78 in [1981mm]
DKBC700S	700 lbs [318kg]	48 in [1219mm]

Features

- CE Compliant. **
- Redundant chain design for safe operation:
 - Load Chain: Carries the load.
 - Safety Chain: Rides along for redundancy.
- Hands-Free Operation.
- Standard “Float” Mode.
- External Retract Control.
- Requires Non-Lubricated Clean/Dry Air.
- Max. Balancing Capacity:
 - Up to **700 lbs. [317kg]**.
- Standard Travel: Up to **78 in. [1981mm]**.
- Optional Limit Switches.
- Optional High Relieving and Feathertouch Controls.
- Multiple Suspension Kits Available.

** CE compliance is not a standard feature on Knight Global Pneumatic Balancers. Please contact us for more details.

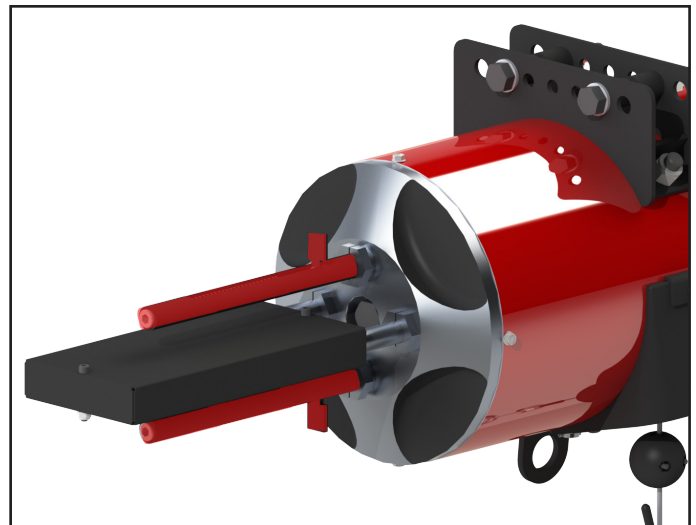

* Limit switches (highlighted in red above) provide the ability to set upper and lower limits, which eliminates unnecessary movement (see page 7).

KBA/KBC EX Series

Knight KBA/KBC External Retract Series

Knight Air Balancers incorporate a standard internal centrifugal brake to insure that any runaway load comes to an immediate and complete halt, additionally Knight offers an optional External Safety Retract Control Series for added protection and adjustability to your application.

The External Safety Retract Control is an adjustable safety feature that regulates the balancer's speed of vertical travel. If a load is lost, the cable on the balancer will not suddenly accelerate upward, because the hydraulic shocks from the external retract control put resistance on the thrust bearing allowing the cable or chain to slowly retract into the air balancer.

The external retract control balancer series are typically used:

- a) If the fixture that is attached to the balancer is light hook picking up a heavy part.
- b) If a part has the tendency to catch on external objects.

In both these applications, the retract will control the cable from suddenly accelerating up.

Features

- (2) Hydraulic Shocks.
- Protective Shock Cover.
- Adjustable Resistance Settings.
- CE Compliant. **
- Hands-Free Operation.
- Standard "Float" Mode.
- Internal Centrifugal Retract Control.
- Requires Non-Lubricated Clean/Dry Air.
- Max. Balancing Capacity:
Up to **1400 lbs. [635kg]** (Reeved).
- Standard Travel: Up to **110 in. [2794mm]**.

** CE compliance is not a standard feature on Knight Global Pneumatic Balancers. Please contact us for more details.

See KBA and KBC section for weight capacities and specifications.

Note: Knight Global's External Safety Retract Control must be installed at Knight Global on a new unit. It cannot be purchased as a separate accessory and installed on an existing air balancer. The external retract is standard on the Dual Drum Balancer.



Cable Series

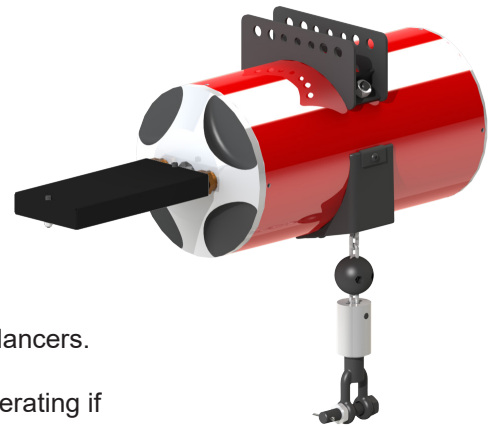

Chain Series

Benefits

- Available for cable and chain balancers.
- Prevents personal injury.
- Prevents cable spool from accelerating if load is lost.
- Provides continuous resistance.
- Multiple Suspension Kits Available.

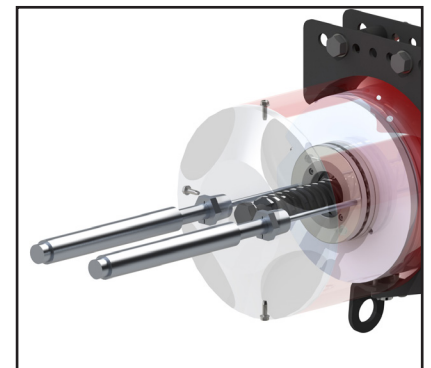

Internal Hydraulic shocks

KBA/KBC Limit Switch Series



Knight KBA/KBC Limit Switch Series

Knight External Limit Switch Balancers incorporate up to (2) two spring loaded rod assemblies (2) limit switches and an external retract control to allow the customer the ability to relay an air pilot signal when predetermined heights have been achieved. Mounted to the bracket is a 5-way pneumatics valve that is de-actuated by the position flag as the balancer travels upward. The external retract control is an adjustable safety feature that regulates the balancer's speed of vertical travel.

The external retract control puts resistance on the thrust bearing allowing the cable or chain to slowly retract into the air balancer to insure that any runaway load comes to an immediate and complete halt.

Features

- (2) Hydraulic Shocks.
- (1-2) Limit Switches.
- Protective Shock Cover.
- Adjustable Resistance Setting
- CE Compliant. **
- Cable or Chain.
- Hands-Free Operation.
- Standard "Float" Mode.
- Requires Non-Lubricated Clean/Dry Air.
- Max. Balancing Capacity:
Up to **1400 lbs. [635kg]** (Reeved).
- Standard Travel: Up to **110 in. [2794mm]**.

** CE compliance is not a standard feature on Knight Global Pneumatic Balancers. Please contact us for more details.

See KBA and KBC section for weight capacities and specifications.

When specifying an Air Balancer, it is recommended to use 80% of the rated load to determine your load capacity. This approach compensates for the normal fluctuations within the plant compressed air supply. Balancers are rated at **100 psi [6.8bar]** therefore use the following example to calculate exact load capability.

Formula for Air Balancer sizing:

Example: plant air 80 psi, 350 air balancer, 80% load capability
(0.80 air supply x 350 lbs. = 280 x .80 = 224 lbs. load capability).

Benefits

- Optional High Relieving and Feathertouch Controls.
- Multiple Suspension Kits Available.

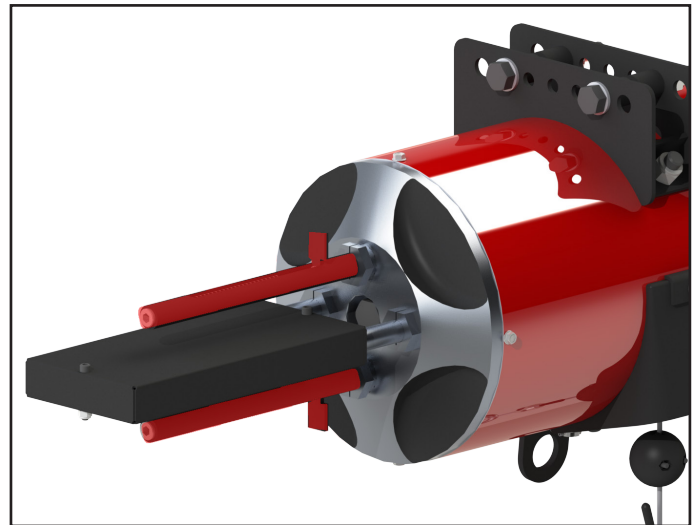

* Limit switches (highlighted in red above) provide the ability to set upper and lower limits, which eliminates unnecessary movement.

RKBA Series

Knight RKBA Reeved Cable Series

Knight Global's RKBA Series Reeved Cable Pneumatic/Air Balancers are primarily designed for weights exceeding **450 lbs. [204 kg]**. Reeving an Air Balancer increases the mechanical advantage of the product. Knight's Reeved Air Balancers come standard with a Knight swiveling shackle on a pulley. When reeving an Pneumatic Balancer, the stroke length is half the length of a standard Balancer.



Features

- CE Compliant. **
- Hands-Free Operation.
- Standard "Float" Mode.
- Internal Centrifugal Retract Control.
- Requires Non-Lubricated Clean/Dry Air.
- Max. Balancing Capacity:
Up to **1,400 lbs. [635kg]**.
- Standard Travel: Up to **55 in. [1397mm]**.

Benefits

- Chain Configuration available.
- Optional External Retract Controls.(EX models)
- Optional High Relieving and Feathertouch Controls.
- Optional Tandem and Tandem Reeved Series.
- Multiple Suspension Kits Available.
- With Heavier Loads, Cable has a Greater Chance of "Bird-Caging" or Pre-Mature Wearing.

** CE compliance is not a standard feature on Knight Global Pneumatic Balancers. Please contact us for more details.

RKBA SERIES CAPACITIES

Model	Rated Capacity lbs. [kg]	Maximum Travel in. [mm]
RKBA450-036	450 lbs. [204kg]	36 in. [914mm]
RKBA450-055	450 lbs. [204kg]	55 in. [1397mm]
RKBA700-036	700 lbs. [318kg]	36 in. [914mm]
RKBA1000-040	1,000 lbs. [454kg]	40 in. [1016mm]
RKBA1400-027	1,400 lbs. [635kg]	27 in. [685mm]

When specifying an Air Balancer, it is recommended to use 80% of the rated load to determine your load capacity. This approach compensates for the normal fluctuations within the plant compressed air supply. Balancers are rated at **100 psi [6.8bar]** therefore use the following example to calculate exact load capability.

Formula for Air Balancer sizing:

Example: plant air 80 psi, 350 air balancer, 80% load capability
(0.80 air supply x 350 lbs. = 280 x .80 = 224 lbs. load capability).

RKBA SERIES SPECIFICATIONS

Model	(A) in. [mm]	(B) (min.) in. [mm]	(C) in. [mm]	(D) in. [mm]	Product Weight lbs [kg]
RKBA450-036	8 1/2 [216]	23 [584]	6 1/2 [165]	15 1/2 [394]	65.5 [30]
RKBA450-055	10 3/4 [273]	28 [711]	10 3/4 [273]	16 1/2 [419]	92 [42]
RKBA700-036	8 3/4 [222]	28 [711]	8 3/4 [222]	16 3/4 [426]	80.5 [36]
RKBA1000-040	9 3/4 [248]	28 [711]	10 3/4 [273]	16 1/2 [419]	116.5 [53]
RKBA1400-027	9 3/4 [248]	28 [711]	10 3/4 [273]	21 13/16 [554]	95.5 [43]

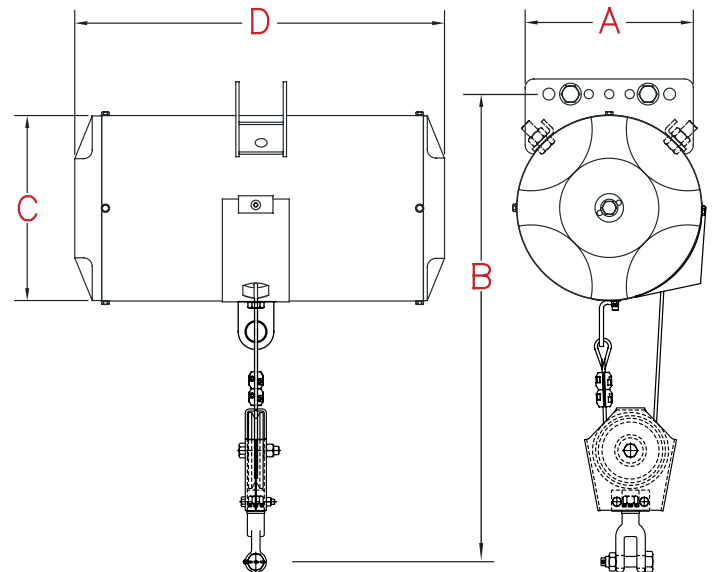

RKBC Series



Knight RKBC Reeved Chain Series

Knight Global's RKBC Series Reeved Chain Air Balancers are primarily designed for weights exceeding **400 lbs. [181 kg]**. Reeving an Air Balancer increases the mechanical advantage of the product. Knight Global's Reeved Cable Air Balancers come standard with a Knight swiveling shackle on a pulley. When reeving an Pneumatic Balancer, the stroke length is half the length of a standard Balancer.

Features

- CE Compliant. **
- Hands-Free Operation.
- Standard "Float" Mode.
- Internal Centrifugal Retract Control.
- Requires Non-Lubricated Clean/Dry Air.
- Max. Balancing Capacity:
Up to **1,400 lbs. [635kg]**.
- Standard Travel: Up to **55 in. [1397mm]**.

Benefits

- Cable Configuration available.
- Optional External Retract Controls.(EX models)
- Optional High Relieving and Feathertouch Controls.
- Optional Tandem and Tandem Reeved Series.
- Multiple Suspension Kits Available.

** CE compliance is not a standard feature on Knight Global Pneumatic Balancers. Please contact us for more details.

RKBC SERIES CAPACITIES

Model	Rated Capacity lbs. [kg]	Maximum Travel in. [mm]
RKBC400-055	400 lbs. [181kg]	55 in. [1397mm]
RKBC450-033	450 lbs. [204kg]	33 in. [838mm]
RKBC700-033	700 lbs. [318kg]	33 in. [838mm]
RKBC1000-040	1,000 lbs. [454kg]	40 in. [1016mm]
RKBC1400-026	1,400 lbs. [635kg]	27 in. [685mm]

When specifying an Air Balancer, it is recommended to use 80% of the rated load to determine your load capacity. This approach compensates for the normal fluctuations within the plant compressed air supply. Balancers are rated at **100 psi [6.8bar]** therefore use the following example to calculate exact load capability.

Formula for Air Balancer sizing:

Example: plant air 80 psi, 350 air balancer, 80% load capability
 $(0.80 \text{ air supply} \times 350 \text{ lbs.} = 280 \times .80 = 224 \text{ lbs. load capability})$.

RKBC SERIES SPECIFICATIONS

Model	(A) in. [mm]	(B) (min.) in. [mm]	(C) in. [mm]	(D) in. [mm]	Product Weight lbs [kg]
RKBC400-055	8 1/2 [216]	16 1/2 [419]	6 1/2 [165]	15 1/2 [394]	51 [23]
RKBC450-033	10 3/4 [273]	20 1/2 [521]	10 3/4 [273]	16 1/2 [419]	93 [42]
RKBC700-033	8 3/4 [222]	18 1/2 [470]	8 3/4 [222]	16 3/4 [426]	63 [28]
RKBC1000-040	9 3/4 [248]	20 1/2 [521]	10 3/4 [273]	16 1/2 [419]	78 [35]
RKBC1400-026	9 3/4 [248]	20 1/2 [521]	10 3/4 [273]	21 13/16 [554]	115 [52]

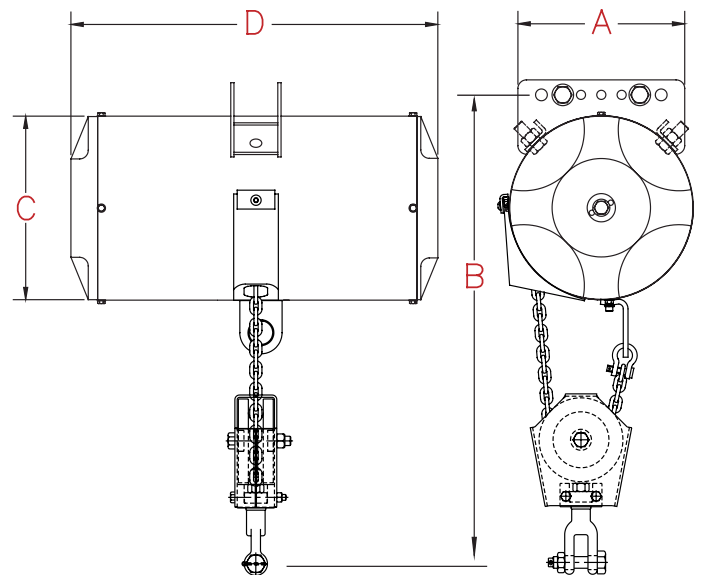

TKBA Series

Knight TKBA Tandem Cable Series

Knight Global's TKBA Series Tandem Cable Air Balancers are primarily designed for weights exceeding **700 lbs. [318kg]**. Tandem Cable Air Balancers were designed to provide the weight lifting capacities of a Reeved Cable Air Balancer application, but to incorporate the extended travel benefits of a single Cable Air Balancer.



Features

- CE Compliant. **
- Hands-Free Operation.
- Standard "Float" Mode.
- Internal Centrifugal Retract Control.
- Requires Non-Lubricated Clean/Dry Air.
- Max. Balancing Capacity:
Up to **1,400 lbs. [635kg]**.
- Standard Travel: Up to **80 in. [2032mm]**.

Benefits

- Chain Configuration available.
- Optional External Retract Controls. (EX models)
- Optional Tandem Reeved Series.
- Multiple Suspension Kits Available.

** CE compliance is not a standard feature on Knight Global Pneumatic Balancers. Please contact us for more details.

When specifying an Air Balancer, it is recommended to use 80% of the rated load to determine your load capacity. This approach compensates for the normal fluctuations within the plant compressed air supply. Balancers are rated at **100 psi [6.8bar]** therefore use the following example to calculate exact load capability.

Formula for Air Balancer sizing:

Example: plant air 80 psi, 350 air balancer, 80% load capability
(0.80 air supply x 350 lbs. = 280 x .80 = 224 lbs. load capability).

TKBA SERIES CAPACITIES

Model	Rated Capacity lbs. [kg]	Maximum Travel in. [mm]
TKBA700-073	700 lbs. [318kg]	73 in [1854mm]
TKBA1000-080	1,000 lbs. [454kg]	80 in [2032mm]
TKBA1400-054	1,400 lbs. [635kg]	54 in [1371mm]

TKBA SERIES SPECIFICATIONS

Model	(A) in. [mm]	(B) (min.) in. [mm]	(C) in. [mm]	(D) in. [mm]	(E) in. [mm]	(F) in. [mm]	Product Weight lbs [kg]
TKBA700-073	8 1/2 [216]	16 1/2 [419]	6 1/2 [165]	15 1/2 [394]	25 1/8 [639]	3 1/4 [83]	159.6 [72]
TKBA1000-080	10 3/4 [273]	20 1/2 [521]	10 3/4 [273]	16 1/2 [419]	25 1/8 [639]	3 1/4 [83]	233.6 [106]
TKBA1400-054	8 3/4 [222]	18 1/2 [470]	8 3/4 [222]	16 3/4 [426]	25 1/8 [639]	3 1/4 [83]	193.6 [88]

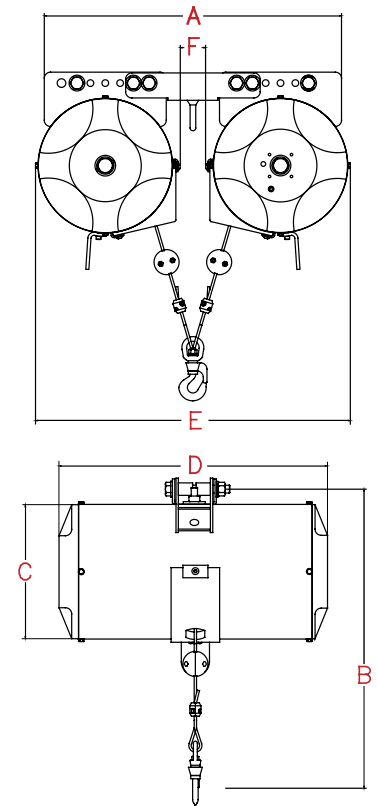

TKBC Series



Knight TKBC Tandem Chain Series

Knight Global's TKBC Series Tandem Chain Air Balancers are primarily designed for weights exceeding **700 lbs. [318kg]**. Tandem Chain Air Balancers were designed to provide the weight capacities of a Reeved Chain Air Balancer application, but to incorporate the extended travel benefits of a single Chain Air Balancer.

Features

- CE Compliant. **
- Hands-Free Operation.
- Standard "Float" Mode.
- Internal Centrifugal Retract Control.
- Requires Non-Lubricated Clean/Dry Air.
- Max. Balancing Capacity:
Up to **1,400 lbs. [635kg]**.
- Standard Travel: Up to **80 in. [2032mm]**.

Benefits

- Cable Configuration available.
- Optional External Retract Controls. (EX models)
- Optional Tandem Reeved Cable Series.
- Multiple Suspension Kits Available.
- With Heavier Loads, Cable has a Greater Chance of "Bird-Caging" or Pre-Mature Wearing.

** CE compliance is not a standard feature on Knight Global Pneumatic Balancers. Please contact us for more details.

When specifying an Air Balancer, it is recommended to use 80% of the rated load to determine your load capacity. This approach compensates for the normal fluctuations within the plant compressed air supply. Balancers are rated at **100 psi [6.8bar]** therefore use the following example to calculate exact load capability.

Formula for Air Balancer sizing:

Example: plant air 80 psi, 350 air balancer, 80% load capability
 $(0.80 \text{ air supply} \times 350 \text{ lbs.} = 280 \times .80 = 224 \text{ lbs. load capability})$.

TKBC SERIES CAPACITIES

Model	Rated Capacity lbs. [kg]	Maximum Travel in. [mm]
TKBC700-067	700 lbs. [318kg]	67 in [1701mm]
TKBC1000-080	1,000 lbs. [454kg]	80 in [2032mm]
TKBC1400-052	1,400 lbs. [635kg]	52 in [1320mm]

TKBC SERIES SPECIFICATIONS

Model	(A) in. [mm]	(B) (min.) in. [mm]	(C) in. [mm]	(D) in. [mm]	(E) in. [mm]	(F) in. [mm]	Product Weight lbs [kg]
TKBC700-067	23 3/4 [603]	24 [610]	6 1/2 [165]	15 1/2 [394]	25 1/8 [639]	3 1/4 [83]	159.6 [72]
TKBC1000-080	23 3/4 [603]	24 [610]	10 3/4 [273]	16 1/2 [419]	25 1/8 [639]	3 1/4 [83]	233.6 [106]
TKBC1400-052	23 3/4 [603]	24 [610]	8 3/4 [222]	16 3/4 [426]	25 1/8 [639]	3 1/4 [83]	193.6 [88]

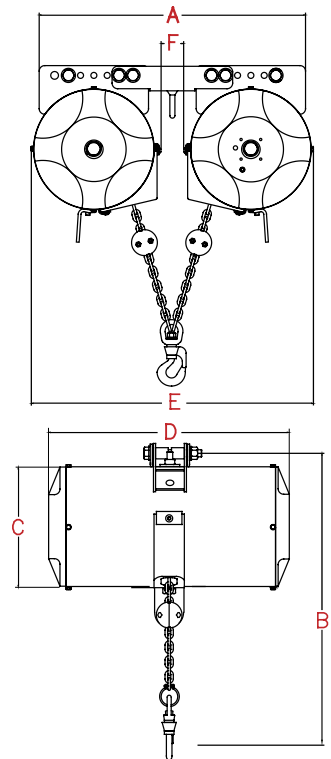

KEAA2000 Series

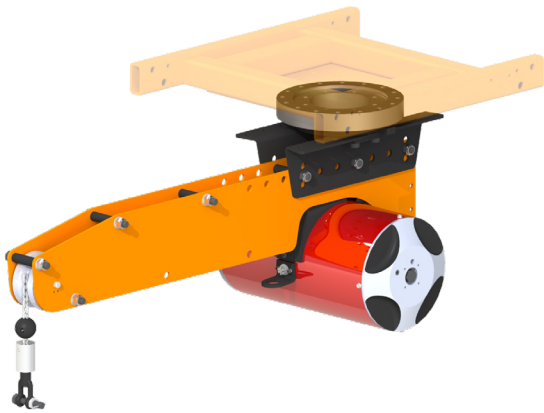
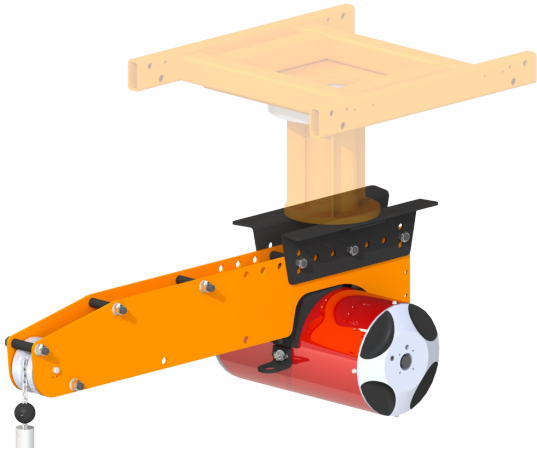

Knight KEAA2000 Dual Bridge Extension Arm with Pneumatic Balancer

Knight Global's KEAA2000 Series Dual Bridge Extension Arms enable the operator to extend beyond the working limits of an overhead rail system within a workstation. A Knight Pneumatic Balancer mounts to the extension arm allowing for a controlled lifting and lowering of loads. Knight's KEAA2000 travels inside Knight's **RAD4110**, **RAD6110**, or **RAD7510** Aluminum Series Rail Systems.

Features

- Dual Bridge Configuration.
- Travels inside Knight's **RAD4110**, **RAD6110**, or **RAD7510** Series Rail.
- CE Compliant upon Request. **
- Various Control Configurations.
- Angular Adjustment in **10°** increments. (**10° UP / 10° DOWN**)
- Horizontal Adjustments:
Up to **6.8 in. [172mm]**. in **2.3 in.** Increments.
- Requires Non-Lubricated Clean/Dry Air.
- Max Balancing Capacity:
Up to **700 lbs. [317kg]**.

** CE compliance is not a standard feature on Knight Global Pneumatic Balancers. Please contact us for more details.

Benefits

- Chain Configuration.
- Expands the reach work area of a typical balancer.
- Allows for 360° rotation.
- Controls Sold Separately (Up/Down or Balance).

KEAA2000 SERIES CAPACITIES

Model	Rated Capacity lbs. [kg]	Maximum Travel in. [mm]
KEAA2000-200	200 lbs. [90kg]	110 in. [2794mm]
KEAA2000-350	350 lbs. [158kg]	67 in. [1701mm]
KEAA2000-500	500 lbs. [226kg]	80 in. [2032mm]
KEAA2000-700	700 lbs. [317kg]	50 in. [1270mm]

When specifying an Air Balancer, it is recommended to use 80% of the rated load to determine your load capacity. This approach compensates for the normal fluctuations within the plant compressed air supply. Balancers are rated at **100 psi [6.8bar]** therefore use the following example to calculate exact load capability.

Formula for Air Balancer sizing:

Example: plant air 80 psi, 350 air balancer, 80% load capability (0.80 air supply x 350 lbs. = 280 x .80 = 224 lbs. load capability).

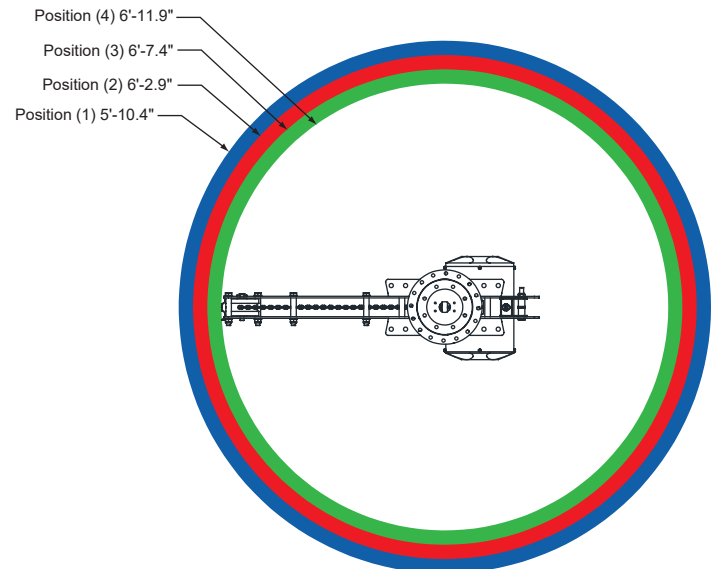

(4) Position Adjustments

KEAA2000 Series

ARM ACCESSORIES

Trolleys
(Custom Trolleys Available)

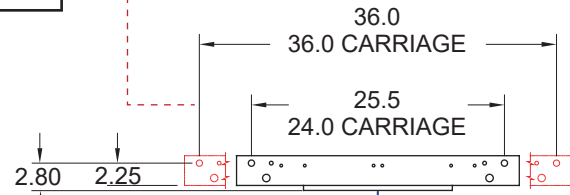
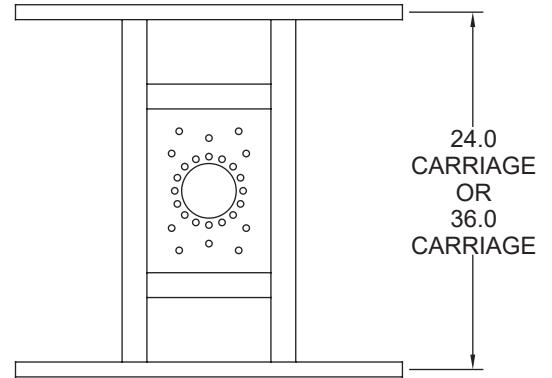
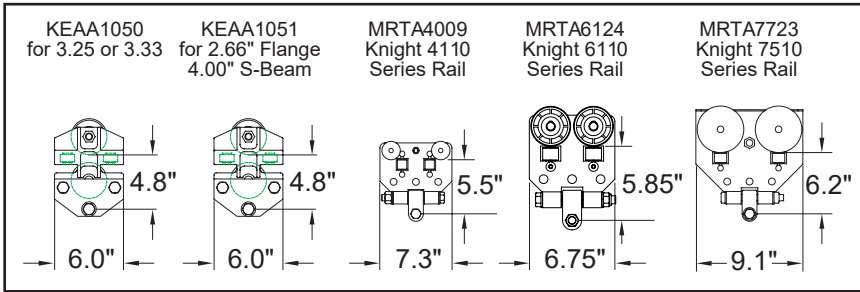

Spacer A

KBC KBC
200 and 350

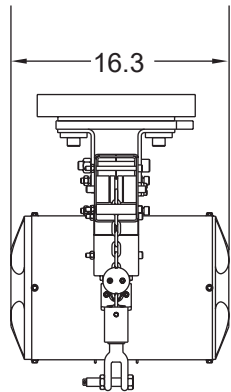

KBC KBC
500 and 700

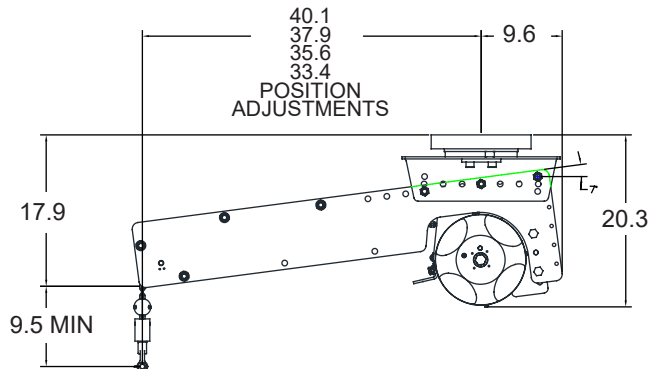
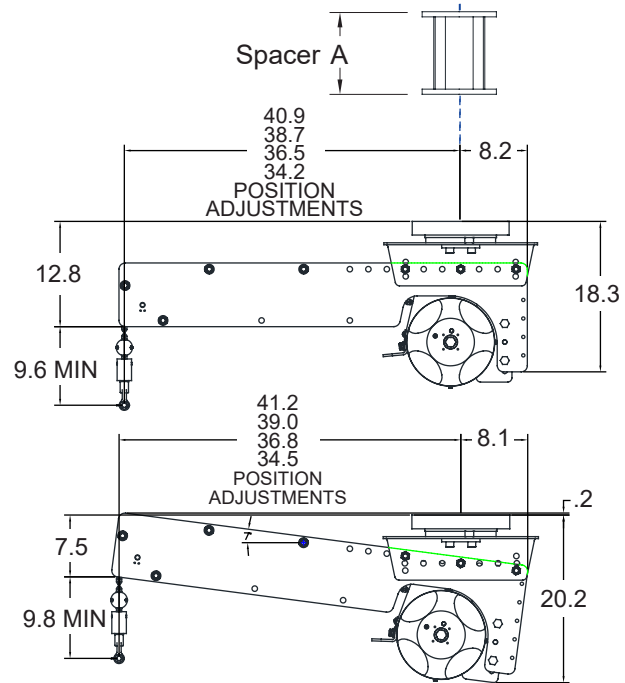
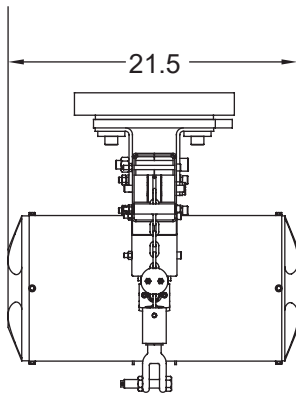

EXAMPLE:

ORDER #: KEAA20_500_A36_B24

Optional [Omit if not required]			
Arm Desc.	Capacity	Spacer	Carriage
KEAA20	XXX	XXX	XXX
	200 350 500 700	Specify Length [Max 36"] (Inches) AXX	B24 B36
ARM		ARM ACCESSORIES	

KEAA2500 Series

Knight KEAA2500 Single Bridge Extension Arm with Pneumatic Balancer

Knight Global's KEAA2500 Series Single Bridge Extension Arms enable the operator to extend beyond the working limits of an overhead rail system within a workstation. A Knight Pneumatic Balancer mounts to the extension arm allowing for a controlled lifting and lowering of loads. Knight's KEAA2500 travels inside Knight's **RAD4110**, **RAD6110**, or **RAD7510** Aluminum Series Rail Systems.

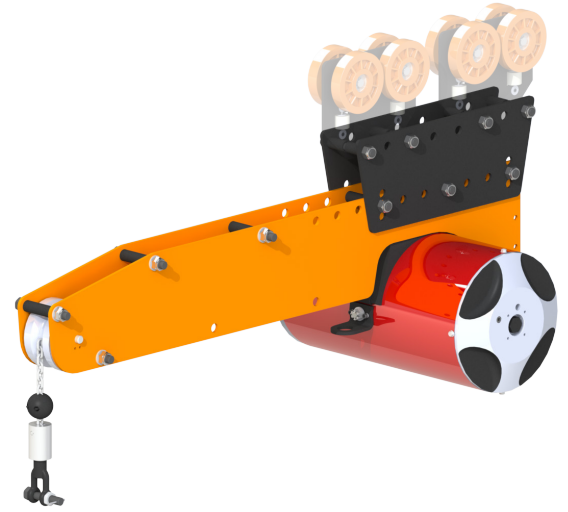

Features

- Single Bridge Configuration.
- Travels inside Knight's **RAD4110**, **RAD6110**, or **RAD7510** Series Rail.
- CE Compliant. **
- Various Control Configurations.
- Angular Adjustment in **10°** increments. (**10° UP / 10° DOWN**)
- Horizontal Adjustments:
Up to **6.8 in. [172mm]**. in **2.3 in.** Increments.
- Requires Non-Lubricated Clean/Dry Air.
- Max Balancing Capacity:
Up to **700 lbs. [317kg]**.

** CE compliance is not a standard feature on Knight Global Pneumatic Balancers. Please contact us for more details.

Benefits

- Chain Configuration.
- Expands the reach work area of a typical balancer.
- Controls Sold Separately (Up/ Down or Balance).

KEAA2500 SERIES CAPACITIES

Model	Rated Capacity lbs. [kg]	Maximum Travel in. [mm]
KEAA2500-200	200 lbs. [90kg]	110 in. [2794mm]
KEAA2500-350	350 lbs. [158kg]	67 in. [1701mm]
KEAA2500-500	500 lbs. [226kg]	80 in. [2032mm]
KEAA2500-700	700 lbs. [317kg]	50 in. [1270mm]

When specifying Air Balancers, it is recommended to use 80% of the rated load to determine your load capacity. This approach compensates for the normal fluctuations within the plant compressed air supply. Balancers are rated at **100 psi [6.8bar]** therefore use the following example to calculate exact load capability.

Formula for Air Balancer sizing:

Example: plant air 80 psi, 350 air balancer, 80% load capability
 $(0.80 \text{ air supply} \times 350 \text{ lbs.} = 280 \times .80 = 224 \text{ lbs. load capability}).$

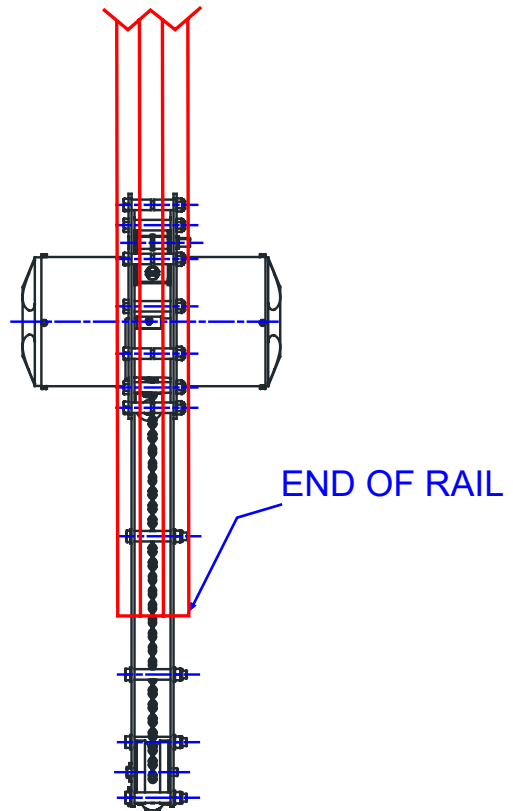

KEAA2500 Series

ARM ACCESSORIES

Trolleys (Custom Trolleys Available)

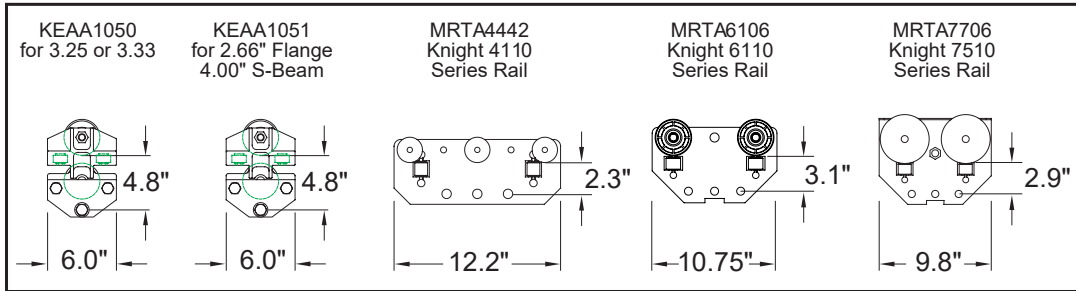

KBC KBC
200 and 350

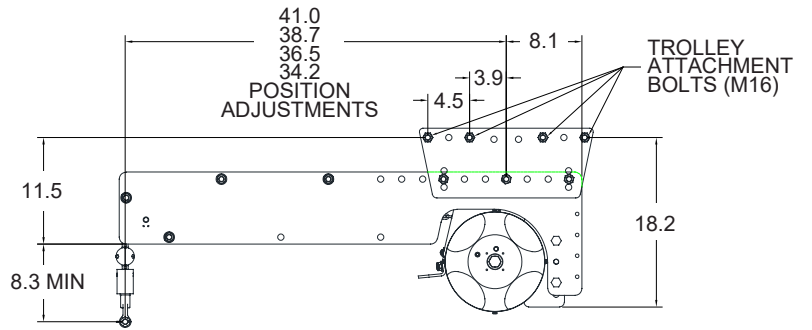
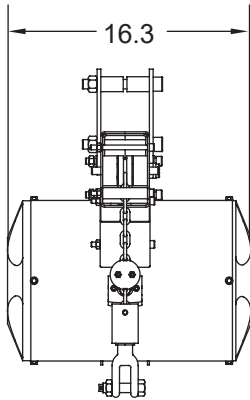

KBC KBC
500 and 700

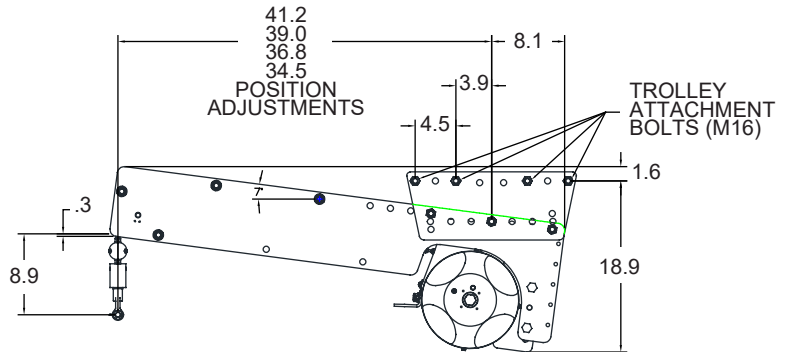
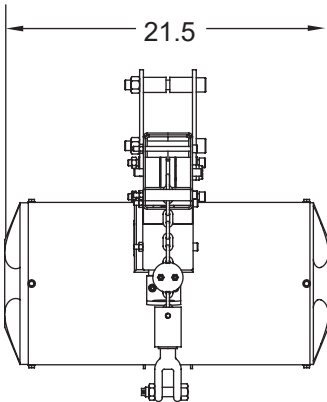

EXAMPLE:
ORDER # : KEAA25_500

Arm Desc.	Capacity
KEAA25	XXX
	200
	350
	500
	700

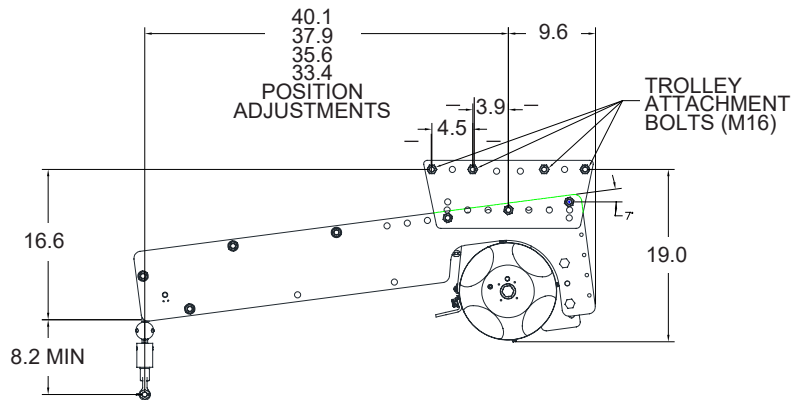

Balancer Controls

Knight Global Air Balancers Pendant Control Series are designed for precision handling of variable weight loads and allows the operator to adjust the handle for an ergonomically comfortable position. Up/ down movement is achieved through the use of customer specified color coded thumb levers or by movement of the control handle (Feather-Touch). Air Balancer Pendant Controls are available in a straight or coiled hose configuration with standard hose lengths of up to 10 ft. [3m].

BCS3017 & BCS3320 Up/ Down Pendant	BCS2326 & BCS3330 Tandem Up/ Down Pendant
 <ul style="list-style-type: none"> • BPA9300 Pneumatic Control Handle. • Two Button Configuration. • 2-way valves used for a single acting air balancer or lift assist that is used for up/ down movement. 	 <ul style="list-style-type: none"> • BPA9300 Pneumatic Control Handle. • Two Button Configuration. • 2-way valves used for a single acting air balancer or lift assist that is used for up/ down movement.
BCS2090 & BCS2322 High Relieving Single Balancer	BCS2018 Single Balancer Control
 <ul style="list-style-type: none"> • Does not allow for variances in weights. • Assists in increasing the air volume. • Ideal for weights exceeding 150 lbs. [68kg] at 80 psi (End Effector and Part). 	 <ul style="list-style-type: none"> • Supports a constant weight at zero gravity. • Ideal for balancing fastening tools. • Ideal for weights not to exceed 150 lbs. [68kg] (End Effector and Part).

Balancer Controls

BCS2215 & BCS2323
Dual Balancer Control



- Controls (2) different weights at zero gravity.
- Primarily used in hands free applications.
- Dual balance creates a zero gravity for the end effector with or without a part.

BCS2213 & BCS2214
Feather-Touch Balancer Control



- Eliminates the need for a separate pendant.
- Allows the operator to control the up and down movements close to the part.
- Ideal for weights not to exceed 150 lbs. [68kg] (End Effector and Part).

Air Connection with Balancer Logic Box

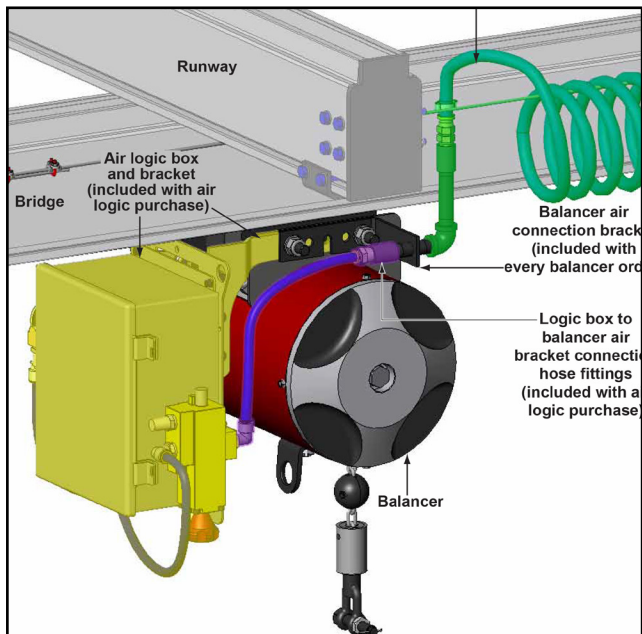

- Includes:
 - Logic Box to Balancer Air Bracket Connection Hose and Fittings.

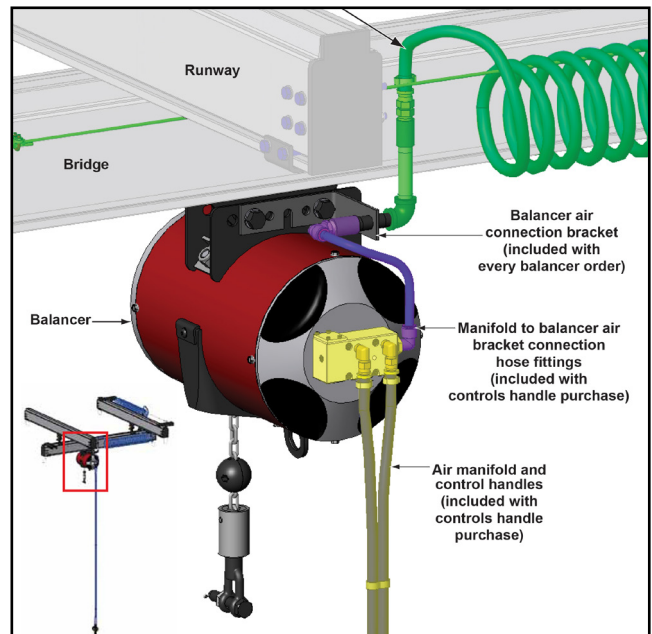

Air Connection with Balancer Manifold







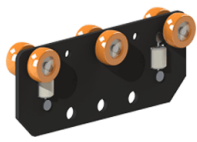
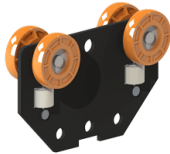
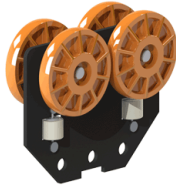
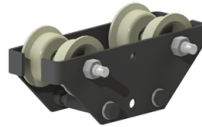

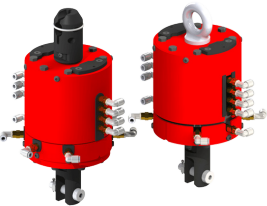

- Includes:
 - Manifold to Balancer Air Bracket Connection Hose and Fittings.

Balancer Accessories

Knight Global Air Balancer Accessories contain a wide variety of accessories that include; Trolleys for Rail Systems, Air Balancer Pulleys, Hooks and Safety Cable Kits.

MRTA4442 Load Trolley for RAD4110 Series Rail	MRTA6106 Load Trolley for RAD6110 Series Rail	MRTA7706 Load Trolley for RAD7510 Series Rail	RTA2013 I-Beam Balancer Load Trolley for W-Beam	RTA2014 I-Beam Balancer Load Trolley for S-Beam
 <ul style="list-style-type: none"> • Transfers loads along the horizontal axis. • Primarily used to attach the balancer to a overhead rail system. • Max. Capacity: Up to 1,100 lbs. [499kg]. 	 <ul style="list-style-type: none"> • Transfers loads along the horizontal axis. • Primarily used to attach the balancer to a overhead rail system. • Max. Capacity: Up to 1,600 lbs. [725kg]. 	 <ul style="list-style-type: none"> • Transfers loads along the horizontal axis. • Primarily used to attach the balancer to a overhead rail system. • Max. Capacity: Up to 3,000 lbs. [1,360kg]. 	 <ul style="list-style-type: none"> • Mounts on overhead W-Beams, I-Beams, and Patented Track. • Used to suspend air balancers by the use of the center mounting holes. • Max. Capacity: Up to 3,000 lbs. [1,360kg]. 	 <ul style="list-style-type: none"> • Mounts on overhead S-Beams. • Used to suspend air balancers by the use of the center mounting holes. • Max. Capacity: Up to 3,000 lbs. [1,360kg].

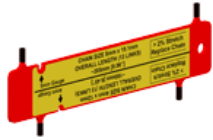
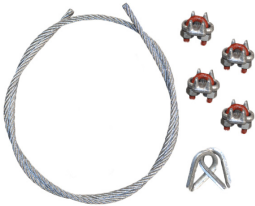
BPA2001/2002 Pneumatic Rotary Unions	BPA2065/2066 Reeved Balancer Pulley	BPA2016 Balancer Hanger Hook	BPA2113 Balancer Hook	BPA2410 Safety Chain Shackle
 <ul style="list-style-type: none"> • Can prevent tangling up of air lines during operation of a lifting device. • Up to (7) pneumatic ports available. • Capacities up to 1,000 lbs. [454kg] • Pad Eye or Chain Nest options 	 <ul style="list-style-type: none"> • Doubles the balancing capacity of a chain balancer. • Enclosed with Steel Safety Guard. • BPA2065 - for Cable • BPA2066 - for Chain 	 <ul style="list-style-type: none"> • Connects air balancers quickly and securely to pad-eyes and overhead hangers. • Bolted to the top hanger bracket provided on each air balancer. 	 <ul style="list-style-type: none"> • Connects Air Balancers quickly and securely to fixtures and end effectors. • 1 ton capacity Crosby/ Bullard® Golden Gate size 2 Pin-Lok Hook with self closing gate. 	 <ul style="list-style-type: none"> • Connects air balancers quickly and securely to pad-eyes and overhead hangers. • Features a female clevis or direct connections.

BPA2035 Quick Connect/ Disconnect	KSAA1003 Precision Chain Wear Gauge	RWA4133 Safety Cable Kit	NICORWA4133 Safety Cable Kit w/ Oval Sleeves	FDA4133 Eye Bolt Safety Cable Kit
 <ul style="list-style-type: none"> • Allows for fast connections and disconnections of fixtures and end effectors. 	 <ul style="list-style-type: none"> • Used to measure the wear on Servo Hoists and Pneumatic Air Balancers 4mm/5mm galvanized chain. 	 <ul style="list-style-type: none"> • Carbon Steel "Galvanized Wire Rope" GWC. • Cable Thickness: 0.25 in. [6mm]. • Crosby Saddle Clamps. • Standard lengths: 5 ft. [1.5m]. 	 <ul style="list-style-type: none"> • Carbon Steel "Galvanized Wire Rope" GWC. • Cable Thickness: 0.25 in. [6mm]. • Copper Oval Sleeves. • Standard lengths: 10 ft. [3m]. 	 <ul style="list-style-type: none"> • Carbon Steel "Galvanized Wire Rope" GWC. • Cable Thickness: 0.25 in. [6mm]. • Crosby Saddle Clamps. • Eye Bolt Connection. • Standard lengths: 6 ft. [1.82m].