

Lift and Tilt Table

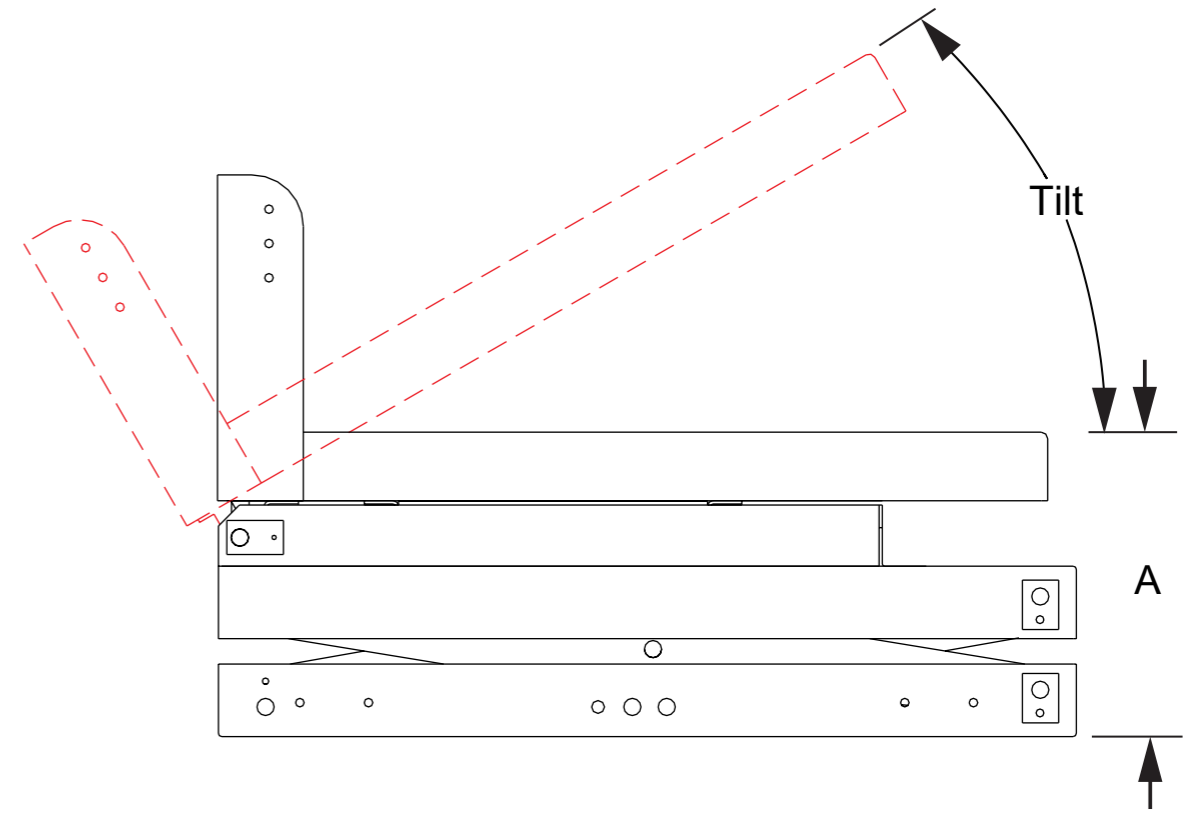
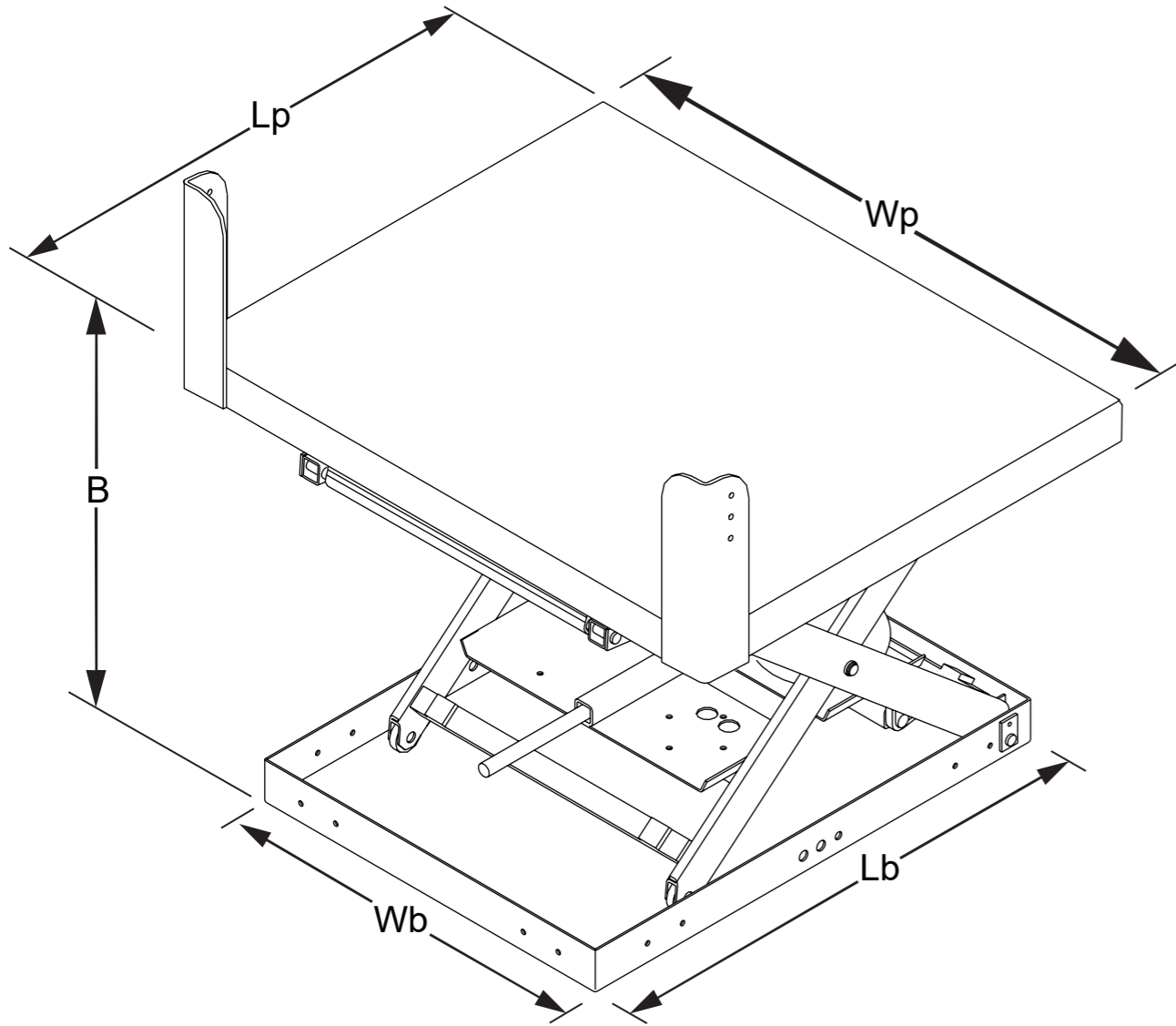

Model	Capacity Lbs [kg]	Closed (A) in [mm]	Extended (B) in [mm]	Tilt	Base Size (Lb x Wb) in [mm]	Platform Size (Lp x Wp) in [mm]
LT4860-2000	2,000 [907]	16 [406]	42 [1,066]	0°-40°	38 x 50 [965 x 1,270]	38 x 50 [965 x 1,270] to 60 x 48 [1,524 x 1,219]
LT4860-4000	4,000 [1,814]					
LT4860-6000	6,000 [2,722]					
LT5684-4000	4,000 [1,814]	17.25 [438]	50 [1,270]		42 x 62 [1,067 x 1,575]	42 x 62 [1,066 x 1,575] to 84 x 56 [2,134 x 1,422]
LT5684-6000	6,000 [2,722]					

Note: Tables, Lifts and Carts are available with a variety of accessories, safety features and equipment. Optional Safety Equipment including but not limited to: perimeter fence guarding, bellows skirting, safety mats, audible signals, light signals, toe guards, special control guarding, etc. These are not included unless otherwise stated in the product descriptions. Please check with your state, local or plant safety for requirements. Please contact your local Knight Global representative for more detailed information. Knight Global will be happy to quote any and all safety equipment needed to meet your requirements.