

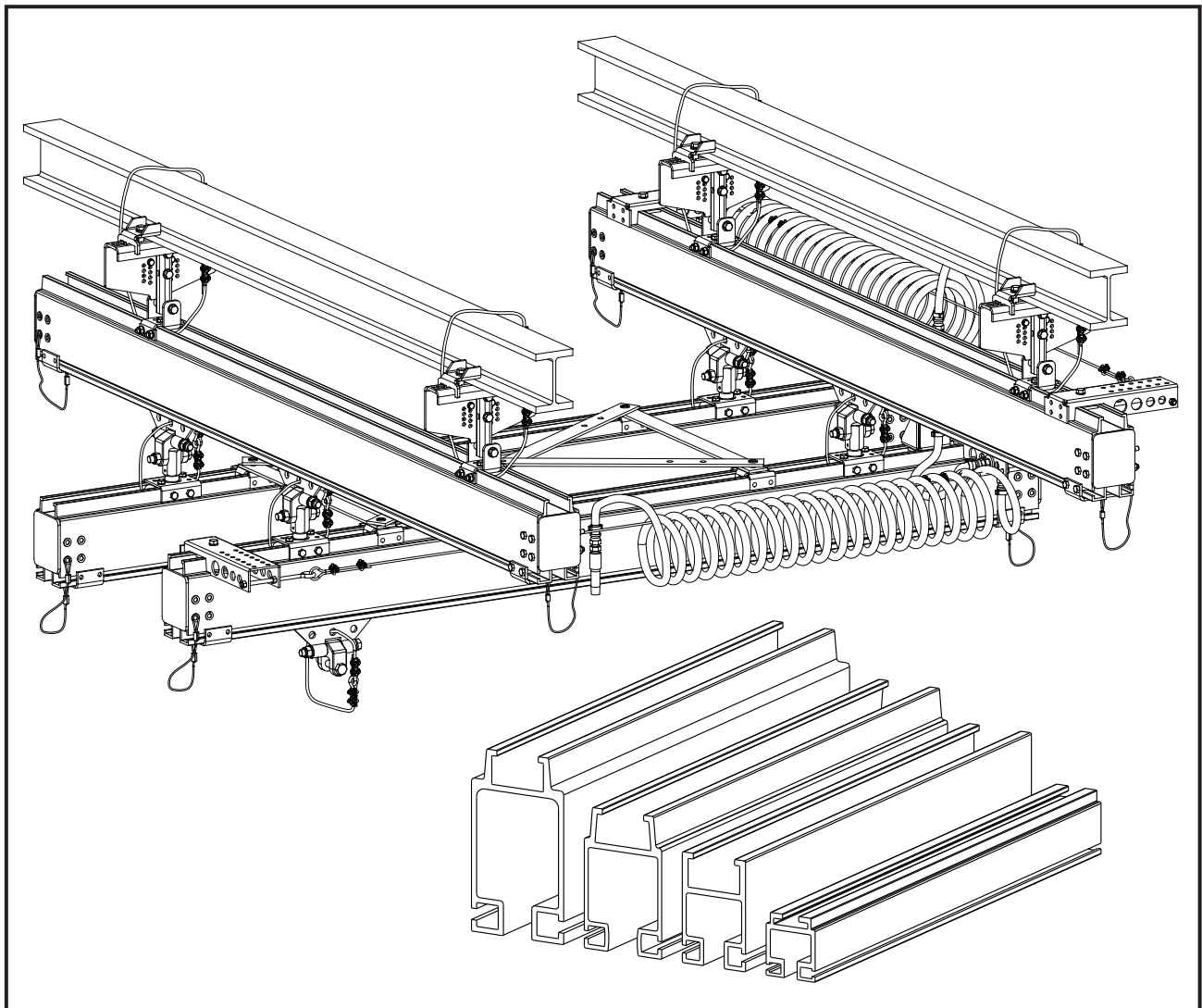

KNIGHT GLOBAL

Enclosed Track Aluminum Rail Operation, Installation, and Maintenance Manual



For RAIL MODELS: RAD7510, RAD6110, RAD4110 and TR2000
ORIGINAL INSTRUCTIONS

THIS MANUAL CONTAINS IMPORTANT INFORMATION REGARDING, SAFETY, INSTALLATION, MAINTENANCE, AND OPERATION OF KNIGHT GLOBAL ENCLOSED TRACK RAIL SYSTEM AND SHOULD BE AVAILABLE TO ALL PERSONNEL RESPONSIBLE FOR USING ENCLOSED TRACK RAIL SYSTEM.

REV: KRAD20240528

This manual provides important information for all personnel involved in the installation, operation and maintenance of Knight Global Enclosed Track Aluminum Rail System. All personnel must read this document before operating equipment.

Every effort has been made to provide complete and accurate product information in this manual. However, due to product improvements and changes, discrepancies and omissions may be present. Visit our website at www.knightglobal.com for updated information on all our products.

It is the responsibility of the end user to exercise common sense and judgment when performing the tasks described in this manual. If any procedure seems inaccurate, incomplete or unsafe please put the equipment in a safe condition and contact Knight Global service department for assistance.

Throughout this manual there are steps and procedures that if not performed correctly can result in personal injury or equipment damage. The following signals and words are used to identify the level of potential hazard.

	⚠ WARNING
	Indicates a hazard which will cause severe injury, death or substantial equipment damage.

	⚠ CAUTION
	Indicates a hazard which can or will cause injury or equipment damage.

	⚠ NOTE
	Notifies personnel of assembly, installation, operation or maintenance information which is important but not hazard related.

TABLE of CONTENTS

1. SAFETY 1-1

2. INTRODUCTION 2-1

 Enclosed Track Rail System Overview 2-1

 Closed Track Rail Dimensions 2-2

 General Tool List 2-3

3. RAIL INSTALLATION 3-1

 Hangers and Runways 3-1

 Bridge Assembly 3-2

HANGERS 3-3

 Bolt On C-Channel Hanger 3-3

 Adjustable Height I-Beam Clamp Hanger 3-5

 Short Stack Parallel I-Beam Hanger 3-7

 Short Stack Perpendicular I-Beam Hanger 3-9

 Rod and Ball C-Channel Hanger 3-11

 Sway Bracing 3-13

 Short Stack Rod and Ball Swivel I-Beam Hanger 3-15

 Extended Stack Rod and Ball Swivel I-Beam Hanger 3-17

SPLICE KITS 3-19

END CAPS AND STOPS 3-20

 Redundant Stop 3-20

 Mid Rail Stop 3-21

TROLLEYS 3-22

 Balancer Trolley 3-22

 Boss Trolley 3-23

 Yoke Trolley 3-23

 Eye Hook 3-23

END TRUCKS 3-24

 Pivoting End Truck 3-24

 Single Bridge End Truck 3-24

 Dual Bridge End Truck 3-24

 Dual Trolley Single or Dual Bridge End Trucks 3-24

 Rigid Single or Dual Bridge Rigid End Truck 3-26

 Same Plane Single or Dual Bridge End Truck 3-28

 Same Plane Single or Dual Bridge Pivoting End Truck 3-28

ACCESSORIES	3-30
Hose Trolley	3-30
Hose Trolley with Cable Saddle	3-31
Festooned Hose Management Kit	3-32
Coiled Hose Management Kit	3-35
Add On Access Gate	3-39
Integrated Access Gate	3-40
Zone Ramp Limit Switch Assembly	3-41
End of Travel Limit Switch Assembly	3-42
Side-by-Side Hanger	3-43
Bridge Bumper Assembly	3-44
Safety Cabling	3-45
Safety Cabling Components Installation	3-46
Optional Safety Cabling Methods: Nicopress Method	3-48
Optional Safety Cabling Methods: Eyebolt Method	3-52
4. MAINTENANCE	4-1
Inspection Record Requirements	4-1
Duty Rating	4-1
“Rail Inspection Checklist”	4-2
5. TROUBLESHOOTING	5-1
Rails Troubleshooting Chart	5-1
6. SPARE PARTS	6-1
7. DECOMMISSIONING OF A RAIL SYSTEM.....	7-1
8. PERFORMANCE WARRANTY	8-1
APPENDIX	A-1
Enclosed Track Rail Specs. (per ANSI MH27.2)	A-1
Splice Kit Hanger Location.....	A-5

1. SAFETY



⚠ CAUTION

Prior to placing this unit into service owners and user are advised to examine specific local and/or other regulations, including ANSI and OSHA regulations that may apply to the use of this product..

Knight Global recognizes that most companies have a safety program in place at their facility. The Safety Section, Notes, Cautions and Warnings in this manual are intended to supplement and not supersede any existing plant or company safety guidelines or regulations.

Knight Global cannot be aware of or provide for all the procedures by which the rail operations or repairs may be conducted and the hazards which may result from each method. If operation or maintenance not specifically recommended by Knight Global is conducted, it must be ensured that product or personnel safety is not endangered by these actions. Personnel should place the rail products in a safe condition and contact a supervisor and/or Knight Global service department for technical support if they are not sure of an operation, maintenance procedure, or step.

The supporting structure and load attaching devices used in conjunction with Knight Global rail system must have a safety factor of at least five times the rated capacity of the system. If unsure, please consult a registered structural engineer. This is the customer's responsibility.

Lifting and handling equipment is subject to different regulations in each country. These regulations may or may not be specified in this manual. Check local regulations for specific information.

The National Safety Council, Accident Prevention Manual for Industrial Operations and other recognized safety sources make a common point: Employees who work near suspended loads or assist in hooking on or arranging a load should be instructed to keep out from under the load. From a safety standpoint, one factor is paramount: conduct all lifting operations in such a manner that if there were an equipment failure, no one would be injured. Keep out from under a raised load and keep out of the line of force of any load.

The Occupational Safety and Health Act (OSHA) generally passes the burden of compliance with the owner/employer, not the manufacturer. Many OSHA requirements are not concerned or connected with the manufactured product but are associated with the final installation. It is the owners and users responsibility to determine the suitability of a product for any particular use. It is recommended that all applicable industry, trade association, federal, state, and local regulations be checked. Please read all instructions, notes, cautions and warnings before operation.

Rigging: It is the responsibility of the operator to exercise caution, use common sense and be familiar with proper rigging techniques. Refer to ASME B309 for rigging information, American National Standards Institute, 1430 Broadway, New York, NY 10018.

This manual has been written to provide personnel with information required to install, operate, maintain, repair and decommission Knight Global overhead rail systems.

It is extremely important that installers and operators be familiar with servicing procedures of these products and are physically capable of conducting procedures. These personnel should have a general working knowledge that includes the following:

- Proper and safe use and application of mechanics common hand tools as well as recommended tools.
- Safety procedures, precautions and work habits established by accepted industry standards

SAFETY (CONTINUED)

Knight Global cannot know or provide all of the procedures in which product operations or repairs might be conducted and the hazards/results of each method. If operation or maintenance procedures not specifically recommended by the manufacturer are performed, it must be ensured that product safety is not endangered. If unsure of any operation or maintenance procedure, personnel should place the product in a safe condition and contact supervisors and/or the Knight Global service department for assistance.

At least two people are required for the installation or maintenance of a rail system. Many parts are too large and heavy for one person to handle.

All ladders and scaffolding used by the installer must be reliable and capable of supporting the weight of the installer and equipment.

All hoists, handling devices, brackets, hooks, etc. need to be included in the total weight of the suspended load. The suspended load cannot exceed the rated capacity shown on the rail.

A separate lifting device may be needed during installation for runways exceeding 96 in (2438 mm) in length. Attach a safety cable from load to lifting device in case of accidental release from lifting device. Follow all safety precautions when working with overhead rail systems.

To avoid unsafe operating practices which could lead to injury or property damage follow all operating instructions and warnings.

A majority of companies who use enclosed track aluminum rail systems have a safety program implemented. If there is a conflict between guidelines in the manual and similar individual company rules, the more stringent of the two should take precedence.

Load capacities are marked on either side of the rail and should not be exceeded. Extensive testing has been conducted to establish capacity ratings.

The following list provides the operator with potentially dangerous situations to avoid:

- Only personnel trained in safe operation and maintenance of this system should be allowed to operate and maintain the system.
- Visually inspect the rail system before each shift; never use a rail system that appears to be damaged.
- The suspended load cannot exceed the rated capacity shown on the rail.
- When a load is on the rail system, be alert to the load at all times.
- Make sure the load path is clear of all personnel.
- Do not use this system for supporting, lifting, or transporting people unless specifically designed for transporting people (e.g. Knight Ergo Seat).
- Do not swing a suspended load.
- Never leave a load unattended.
- Never cut or weld a suspended load.
- If binding, jamming or overloading occurs do not operate system.
- Any collision or bumping of suspended components should be avoided.

2. INTRODUCTION

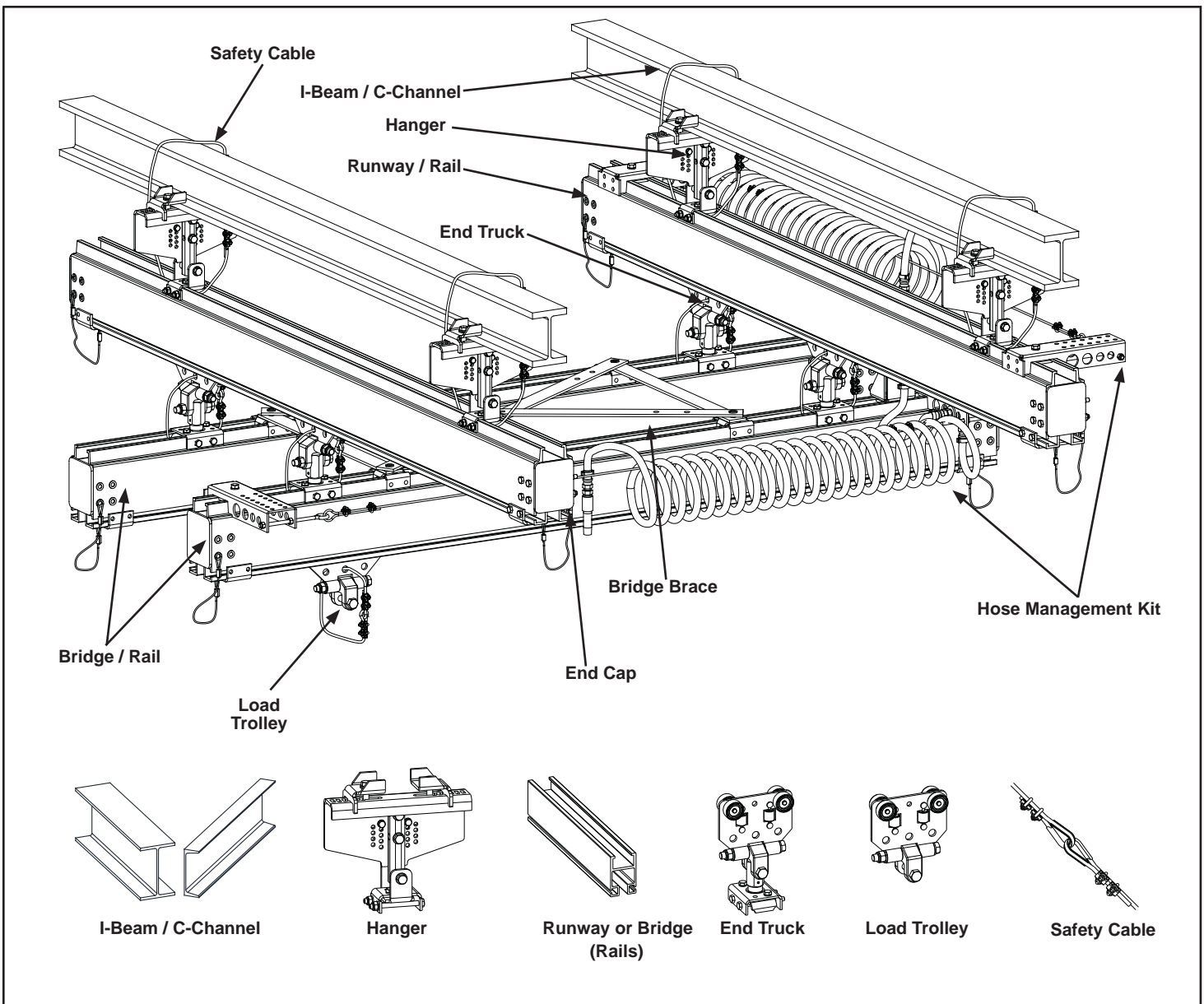

Figure 2-1

MAJOR COMPONENTS AND GENERAL DEFINITIONS FOR THE KNIGHT RAIL SYSTEM

I-Beam and / or C-Channel: Overhead steel that provides basic structural support.

Monorail: A Single length of rail mounted directly to overhead structure.

Runway: Two or more parallel lengths of rail mounted directly to overhead structure, can be dual runway or tri-runway.

Bridge: A span of rail that is suspended from an overhead runway, may be single or dual.

Hangers: Devices that attach to overhead structure providing support for a rail system.

Safety Cable: A redundant safety feature.

End Truck: A connection between bridge and runways.

Trolley: A primary interface between load and rail, suspends a load that allows movement along a rail.

End Caps and Stops: Devices that prevent the load from exiting bridge or runway.

Enclosed Track Rail Dimensions

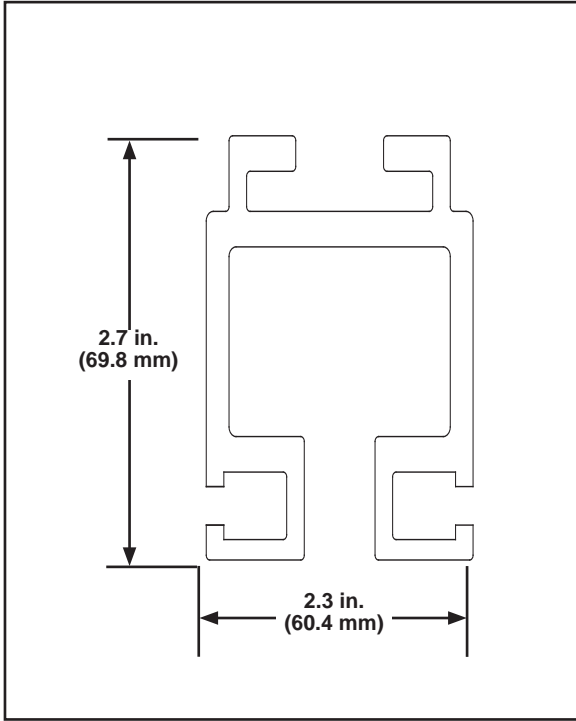

Figure 2-2

TR2000

2.3 lbs/ft [3.33 kg/m]

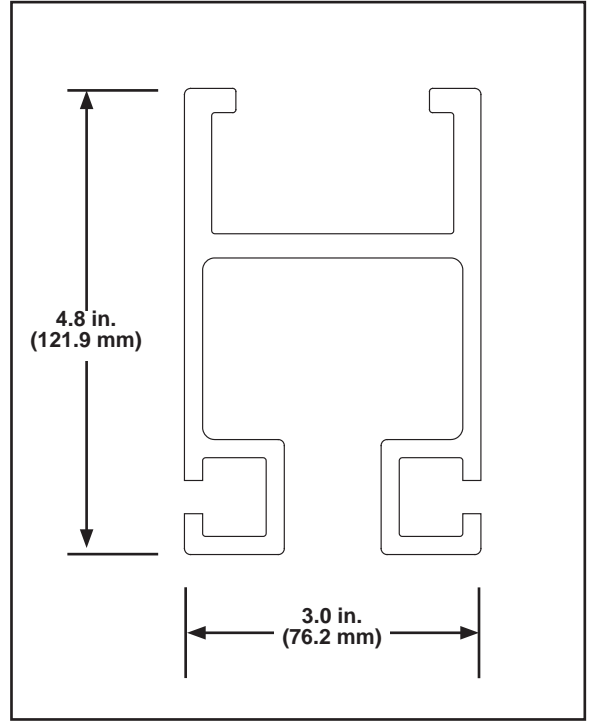

Figure 2-3

RAD 4110

4.3 lbs/ft [6.39 kg/m]

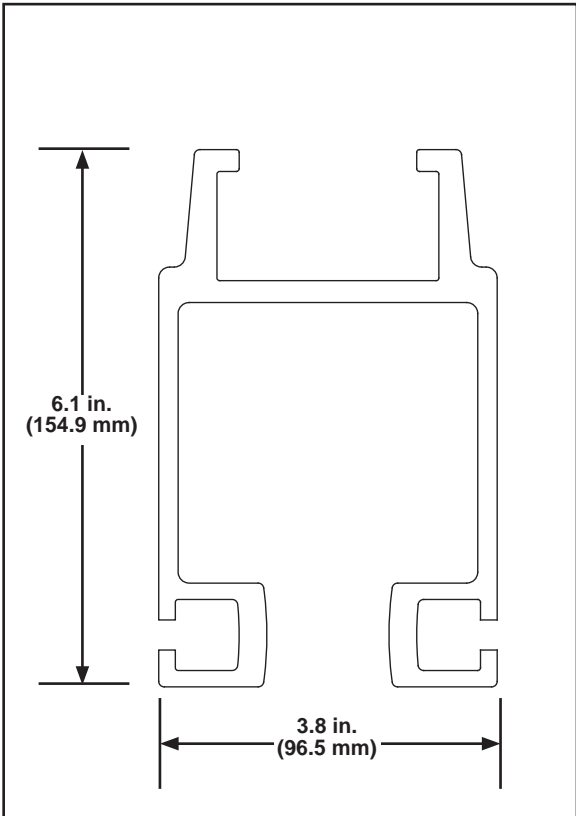

Figure 2-4

RAD 6110

6.0 lbs/ft [8.93 kg/m]

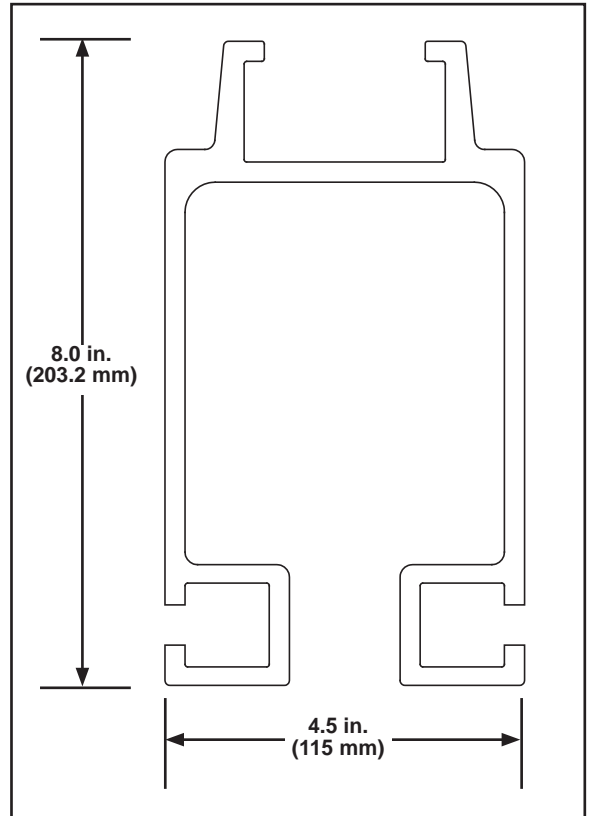

Figure 2-5

RAD 7510

8.3 lbs/ft [12.33 kg/m]

General Tool List

	Metric Allen Wrench Set	Metric Impact Socket Set
	Bubble Level	Lift Truck
	Metric Combination Wrench Set	Heavy Polyurethane Mallet
	Drill Motor	Ladder, Scaffolding, or Man Lift
	Drill Bits	Tape Measure
	Impact Wrench	Laser Level or Transit (optional)
	Metric Drive Socket Set	Safety Wire Pliers

Fasteners

All fasteners must meet property class 8.8 or greater.

DO NOT replace self-locking fasteners.

DO NOT over-tighten fasteners, this may weaken fasteners.

Follow manufacturer’s instructions regarding reuse of locking fasteners.

Recommended Bolt Torques for Aluminum Rail Installation

Refer to instructions of specific component “installation”.

Note 1: For bolts with split lock washers, tighten bolts until lock washer is flat. Do not over tighten.

Note 2: For fasteners with self-locking nuts (e.g., nylock) **tighten until bolt is snug* + ¼ turn**. Do not over tighten.

*Snug is defined when bolt, nut and washers all make firm contact with mating faces. Snug tight is the condition that exists when all plies in a connection have been pulled into firm contact and no space between them by the bolts in the joint. Over tightening of fasteners can cause bending or deformity of parts and/or lock joints that need to pivot. See Figure 2-6.

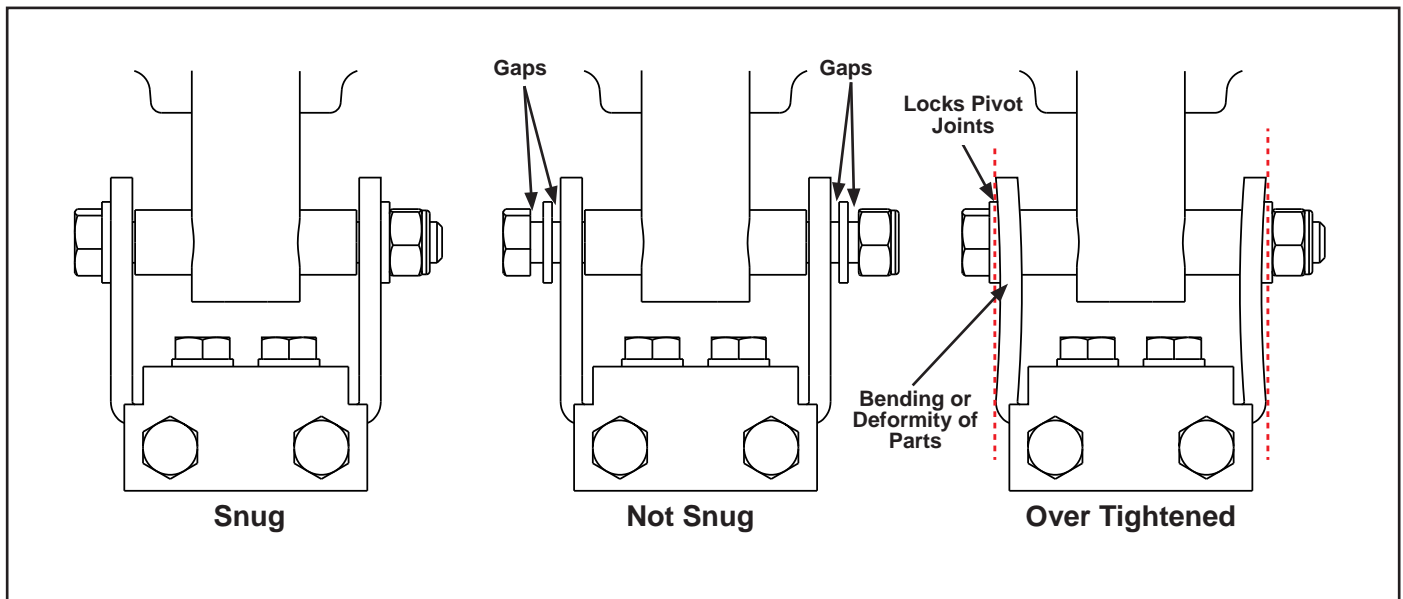

Figure 2-6

3. RAIL INSTALLATION

Hangers and Runways Staging



⚠ WARNING

Use only fasteners provided by Knight Global. Do not use a system if end caps or stop assemblies are removed or damaged. All components must be installed according to instructions in this manual. All overhead attach points must have a safety cable installed according to manufacturer's instructions. Failure to comply may result in injury or death.



⚠ NOTE

Hangers are pre-assembled at Knight Global. Runway lengths are pre-cut per system design or are available in standard lengths and can be cut to length in field.

This is a general sequence of instructions. Refer to specific hanger component sections for detailed instructions.

- Step 1. Unpack hangers from boxes and remove shipping braces from rail bundle. Verify parts match order and inspect for any damage during shipping. If damage is noted, contact Knight Global.
- Step 2. Verify runway lengths to system layout.
- Step 3. Select first rail section for installation and install hangers into bracket channel on runway per layout. See Figure 3-1.
- Step 4. Verify four end cap attachment holes are drilled on each end of rail. If no holes are drilled on one end, use that end for splicing.
- Step 5. Hoist rail section and hangers to support structure per hanger installation instructions.
- Step 6. Install splice kits per instruction where needed according to system layout. Refer to this manual section "Splice Kits".page 3-19.
- Step 7. Repeat for additional rail sections.
- Step 8. Install end caps and stops per instructions after rolling bridge, load trolleys and/or festooning trolleys into runway rails.

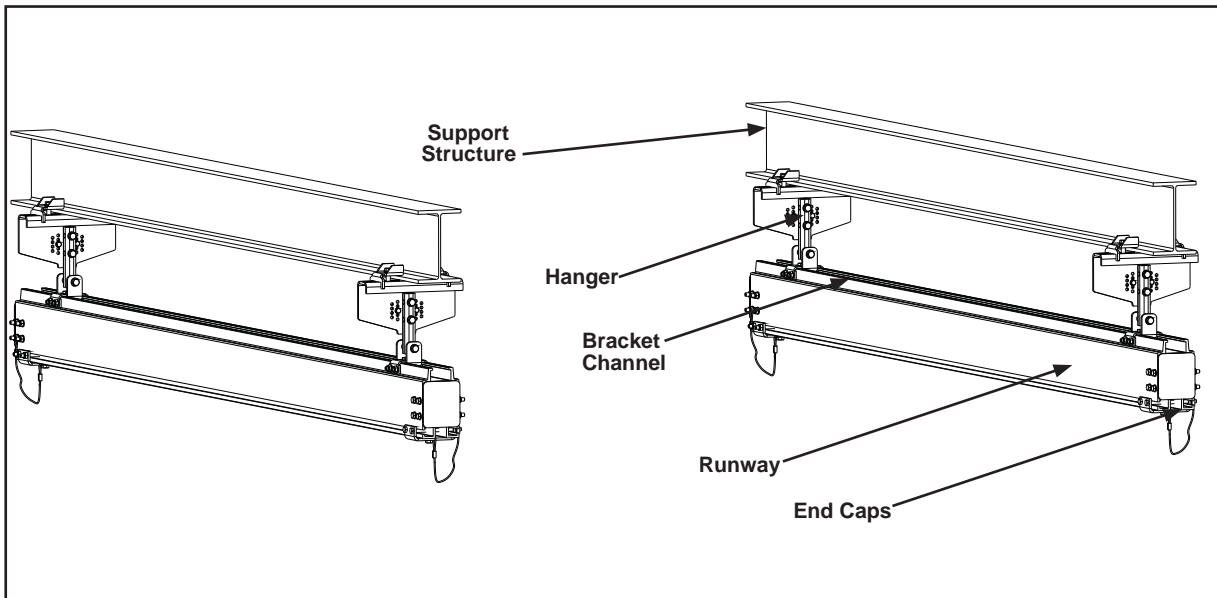

Figure 3-1

Bridge Assembly Staging



WARNING

Use only fasteners provided by Knight Global. Do not use a system if end caps or stop assemblies are removed or damaged. All components must be installed according to instructions in this manual. All overhead attach points must have a safety cable installed according to manufacturer's instructions. Failure to comply may result in injury or death.

Single, dual, and special order bridges are supplied pre-assembled.

The following is a general sequence of installation instructions. Refer to specific component sections for detailed instructions.

- Step 1. Select rail section that matches bridge length on system layout.
- Step 2. Unpack end trucks from boxes and inspect per instructions.
- Step 3. Slide end trucks into bracket channel on bridge rail per instructions. See Figure 3-2. Refer to this manual section "End Trucks" page 3-24.
- Step 4. Verify that centers of end trucks match centers of runway rails.
- Step 5. Hoist rail section and roll end truck trolleys into runways.
- Step 6. Continue end truck installation per instructions.
- Step 7. **To install carriage or fixture:** Remove end caps/stops from one end of bridge.
- Step 8. Roll load trolley or hoist trolley into rail channel. See Figure 3-3.
- Step 9. Install end caps and stops. See Figure 3-3. Refer to this manual section "End Caps and Stops" page 3-20.

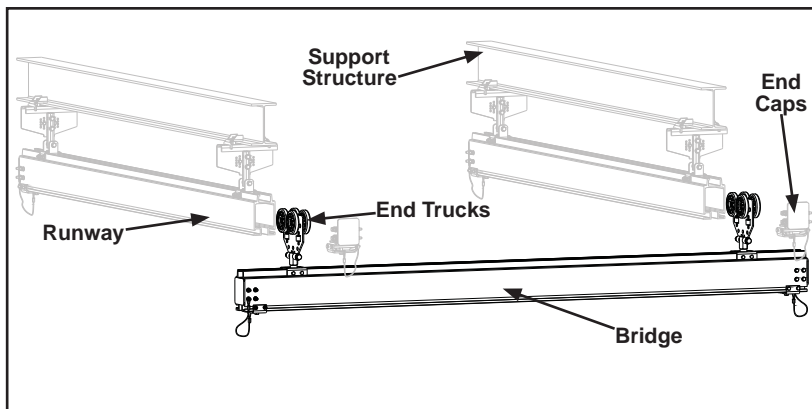

Figure 3-2

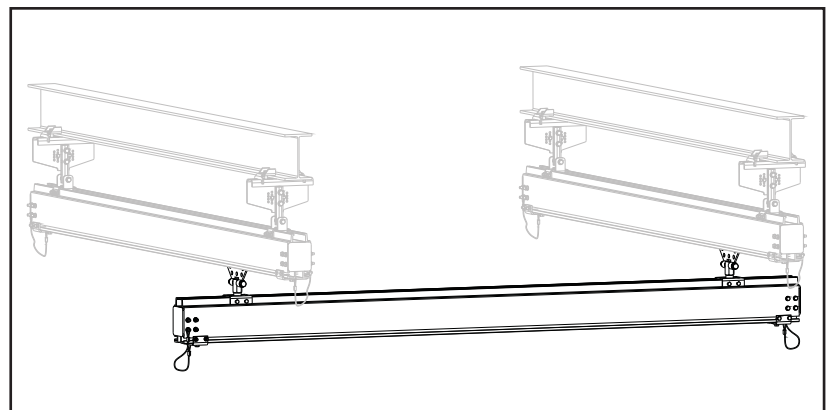

Figure 3-3

HANGERS

Bolt On C-Channel Hanger Installation

Part Number(s): TRH2035, MRHA40351

WARNING

Use only fasteners provided by Knight Global. Do not use a system if end caps or stop assemblies are removed or damaged. All components must be installed according to instructions in this manual. All overhead attach points must have a safety cable installed according to manufacturer's instructions. Failure to comply may result in injury or death. Refer to page 2-3 for definition of "snug".

- Step 1. Refer to system layout for hanger position.
- Step 2. Using Bolt On C-Channel bracket as a template, transfer hole pattern to overhead structure. Drill with 17/32 in (13 mm) drill bit. See Figure 3-4 and Figure 3-5.

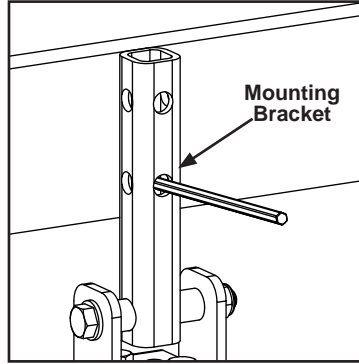

Figure 3-4

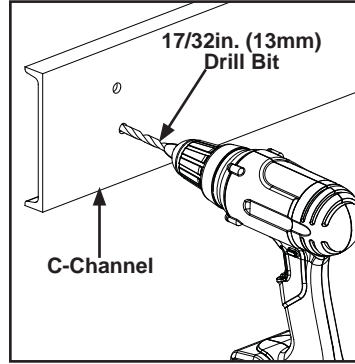

Figure 3-5

- Step 3. Remove cross bolts. Slide rail mounting bracket on top of bracket channel and tap plate into bracket channel at top of runway rail. Position per system layout. See Figure 3-6.
- Step 4. Use a lift assist to raise hangers and rail into position.
- Step 5. Align holes with bolt on C-Channel bracket holes. See Figure 3-7.
- Step 6. Insert two (2) M12 x 50 mm HHCS with M12 flat washers through hanger bracket and C-Channel. Install two (2) M12 nylock nuts with washers. **Tighten until bolts are snug + 1/4 turn.** Do not over tighten. Over tightening could cause bracket to bend.
- Step 7. Secure mounting bracket to rail by tightening two (2) M10 x 30 mm HHCS until lock washers are flat. Do not over tighten.
- Step 8. Tighten M12x100mm HHCS hinge bolt until bolt is **snug + 1/4 turn.** Do not over tighten. Over tightening could cause bracket to bend.
- Step 9. Install safety cable. Refer to this manual section "Safety Cabling" page 3-45.

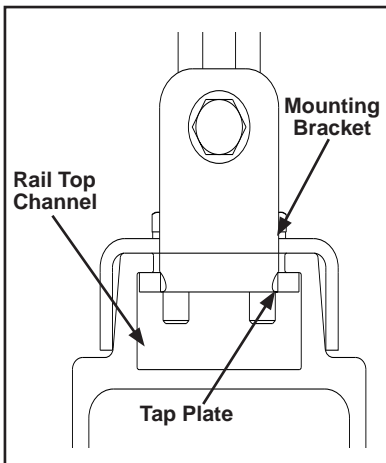

Figure 3-6

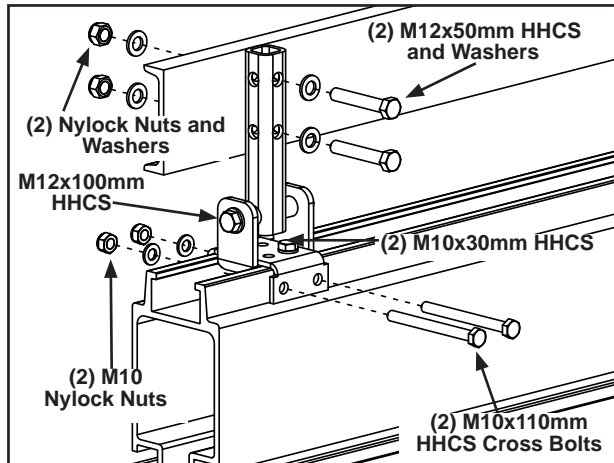

Figure 3-7

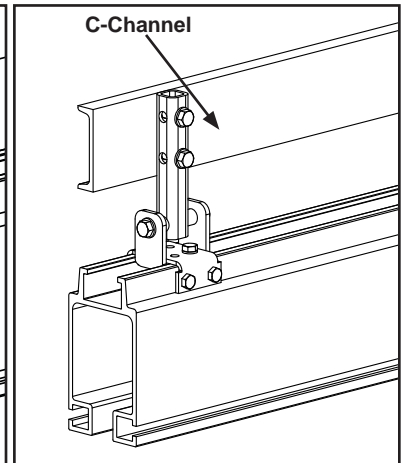

Figure 3-8

Continued on next page.

HANGER INSTALLATION (CONTINUED)

Bolt On C-Channel Hanger (continued)

 **NOTE**

The use of the supplied cross bolts are dictated by local safety regulations and specifications. Knight requires the use of the cross bolts when a hanger is centered over a rail splice.

Cross Bolts

- Step 1. Use rail mounting bracket as template to mark rail. See Figure 3-9
- Step 2. Drill two (2) holes using 13/32 in (11 mm) drill bit. Do not attempt to drill holes inline. Repeat process on opposite side of rail. See Figure 3-10
- Step 3. Install two (2) M10 x 110 mm HHCS with M10 nylock nuts. **Tighten until bolts are snug + 1/4 turn.** Do not over tighten. Over tightening could cause bracket to bend. See Figure 3-11.

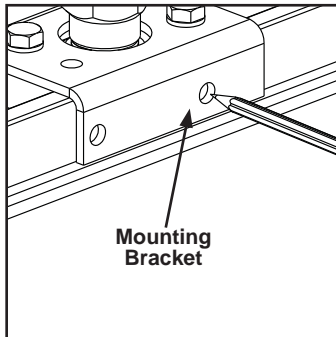

Figure 3-9

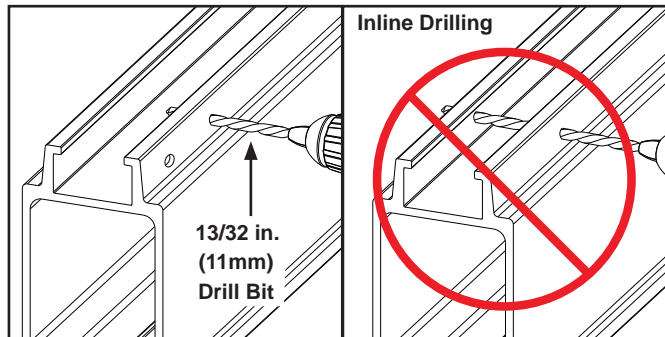

Figure 3-10

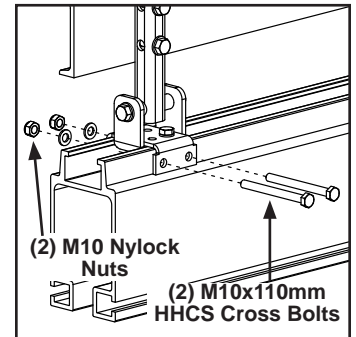

Figure 3-11

HANGER INSTALLATION (CONTINUED)

Adjustable Height I-Beam Clamp Hanger Installation

Part Number(s): TRH20384, TRH22184, MRHS40384, MRHS42184

⚠ WARNING

Use only fasteners provided by Knight Global. Do not use a system if end caps or stop assemblies are removed or damaged. All components must be installed according to instructions in this manual. All overhead attach points must have a safety cable installed according to manufacturer's instructions. Failure to comply may result in injury or death. Refer to page 2-3 for definition of "snug".

⚠ NOTE

Use hanger for direct or offset loads on structural steel I-Beam flange from 2 in to 11 in (51mm to 279 mm). The mounting bracket, tap plate and C-Channel bracket can be turned 90° to accommodate a perpendicular beam structural layout. Max I-Beam Flange thickness: **7/16"** (Thicker flange beams will require modified hanger, available upon request).

- Step 1. Remove cross bolts. Slide rail mounting bracket on top of bracket channel and tap plate into bracket channel at top of runway rail. Position per system layout. See Figures 3-12 through 3-14.
- Step 2. Use a lift assist to raise hangers and rail into position.
- Step 3. Center I-Beam bracket on lower I-Beam flange.

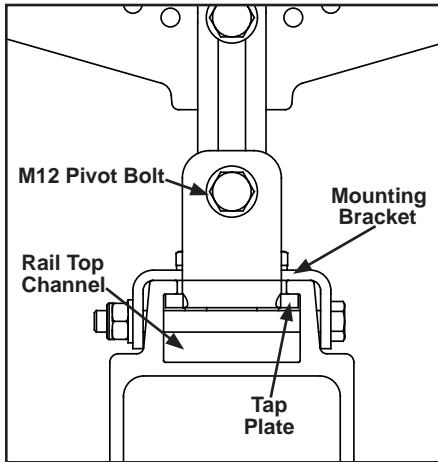

Figure 3-12

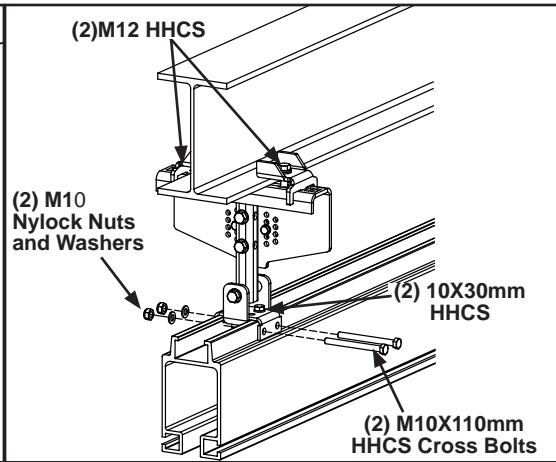

Figure 3-13

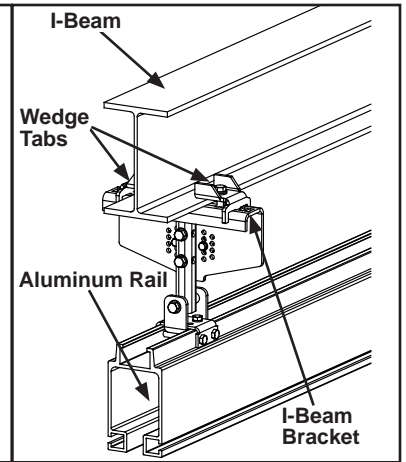

Figure 3-14

⚠ NOTE

Wedge Tabs must rest in one of the I-Beam bracket slots

- Step 4. Place wedge tabs on top of lower flange.
- Step 5. Slide wedge tabs in toward web of beam until two (2) M12 x 100 mm HHCS contact I-Beam flange sides. See Figure 3-15A below.
- Step 6. Tighten M12 x 100mm HHCS bolts , alternating between sides, until I-Beam bracket is tight, flush and centered across bottom of I-Beam. **Tighten until bolts are snug + 1/4 turn**
- Step 7. Ensure I-beam bracket is perpendicular to I-beam lower flange. See Figure 3-15B below.
- Step 8. Secure mounting bracket to rail by tightening two (2) M10 x 30 mm HHCS until lock washers are flat. Do not over tighten.

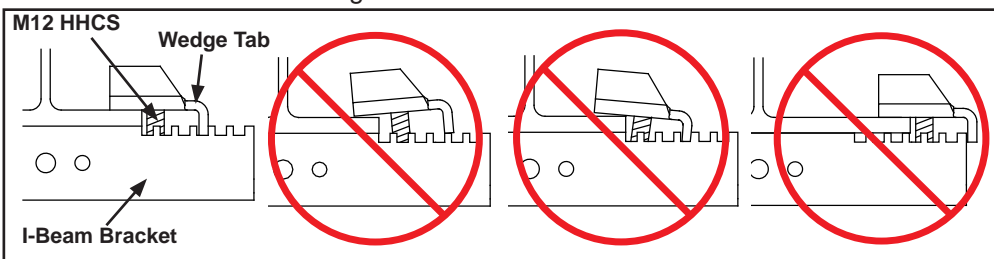

Figure 3-15A

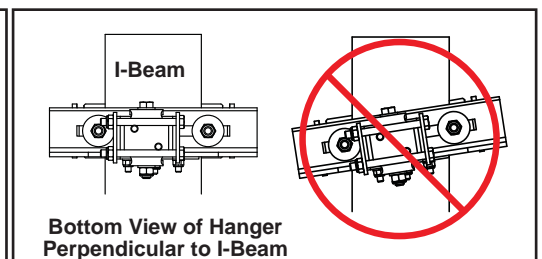

Figure 3-15B

Continued on next page.

HANGER INSTALLATION (CONTINUED)

Adjustable Height I-Beam Clamp Hanger (continued)

▲ NOTE

Knight hanger systems are designed to pivot intentionally to allow for self alignment.

Leveling And Safeguarding

- Step 1. Rail height can be adjusted in 1/8 in (3.2 mm) increments at each hanger; total hanger adjustment is 2 in (50 mm).
- Step 2. Remove two (2) M8 x 30 mm HHCS and loosen two (2) M12 x 40 mm HHCS on I-Beam plate. See Figure 3-16.
- Step 3. Set desired height and line up nearest matching set of 5/16 in (8 mm) clearance holes and reinstall bolts, nuts and washers. See Figure 3-17.
- Step 4. Tighten M12 x 40 mm HHCS and nuts. **Tighten until bolts are snug + 1/4 turn.**
- Step 5. Tighten M8 x 30 mm HHCS and nuts. **Tighten until bolts are snug + 1/4 turn.**
- Step 6. Verify rail pivots at hanger. M12 Pivot Bolt through I-Beam plate should not be over tightened.
- Step 7. Install safety cable at each hanger location. Refer to this manual section “Safety Cabling” page 3-45.

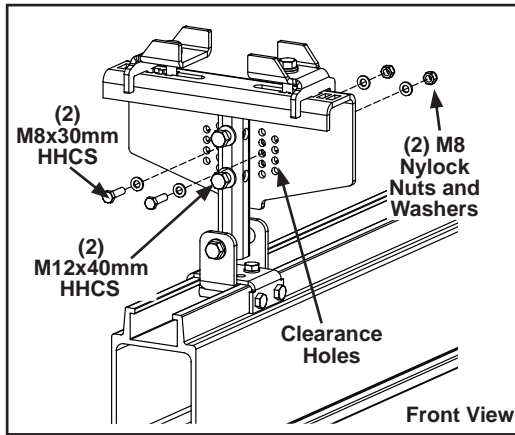

Figure 3-16

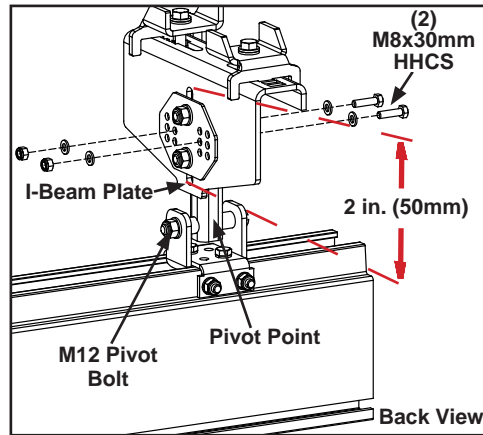

Figure 3-17

Cross Bolts

▲ NOTE

The use of the supplied cross bolts are dictated by local safety regulations and specifications. Knight requires the use of the cross bolts when a hanger is centered over a rail splice.

- Step 1. Use rail mounting bracket as template to mark rail. See Figure 3-18
- Step 2. Drill two (2) holes using 13/32 in (11 mm) drill bit. Do not attempt to drill holes in-line. See Figure 3-19.
- Step 3. Install two (2) M10 x 110 mm HHCS with M10 nylock nuts. **Tighten until bolts are snug + 1/4 turn.** Do not over tighten. Over tightening could cause bracket to bend. See Figure 3-20.

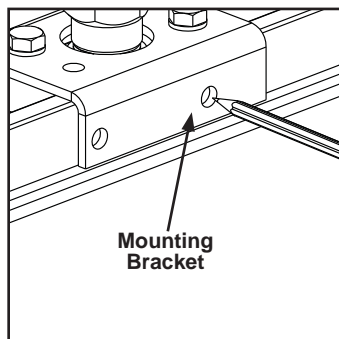

Figure 3-18

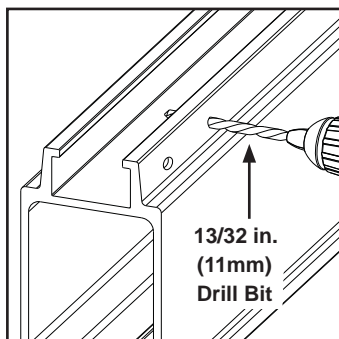

Figure 3-19

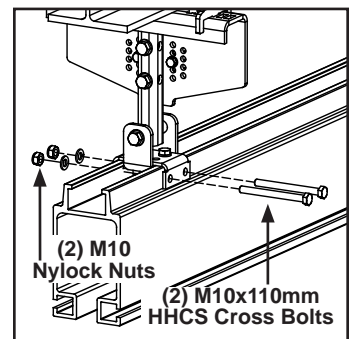
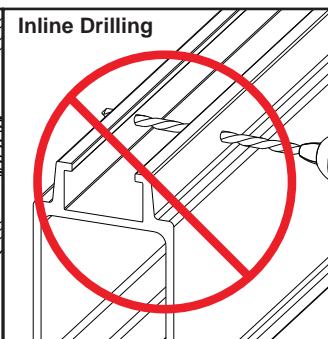





Figure 3-20

HANGER INSTALLATION (CONTINUED)

Short Stack Parallel I-Beam Hanger Installation

Part Number(s): TRH20821, MRHS40821

	 WARNING
	<p>Use only fasteners provided by Knight Global. Do not use a system if end caps or stop assemblies are removed or damaged. All components must be installed according to instructions in this manual. All overhead attach points must have a safety cable installed according to manufacturer's instructions. Failure to comply may result in injury or death. Refer to page 2-3 for definition of "snug".</p>

	 NOTE
	<p>Use hanger for direct loads only. Clamp sizes will fit structural steel I-Beam flanges from two (2) in to eleven (11) in (51 mm to 279 mm). Max I-Beam Flange thickness: 7/16" (Thicker flange beams will require modified hanger, available upon request).</p>

Installation

- Step 1. Remove cross bolts. Slide rail mounting bracket on top of bracket channel and tap plate into bracket channel at top of runway rail. Position per system layout. See Figures 3-21 through 3-23.
- Step 2. Use a lift assist to raise hangers and rail into position.
- Step 3. Center I-Beam bracket on lower I-Beam flange.
- Step 4. Place wedge tabs on top of lower flange. See Figure 3-23.

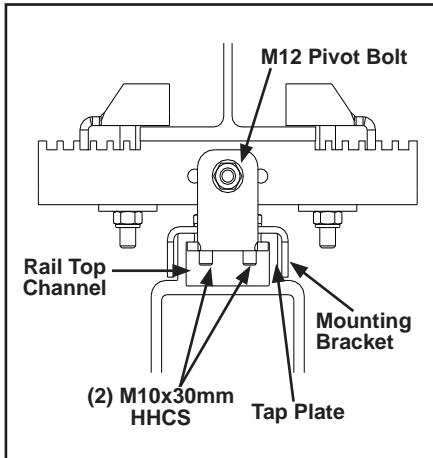

Figure 3-21

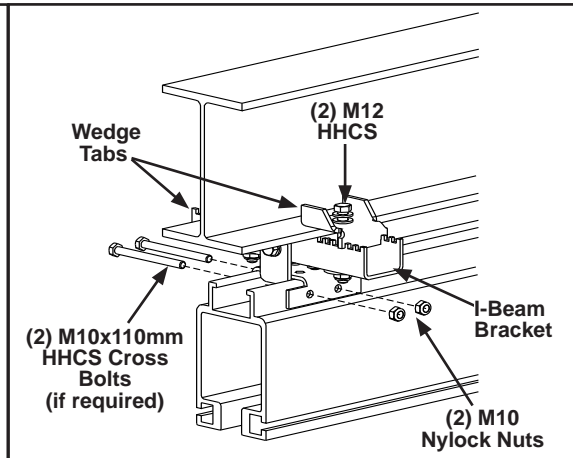

Figure 3-22

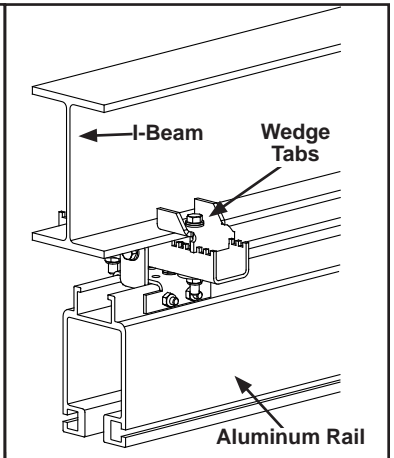

Figure 3-23

	 NOTE
	<p>Wedge Tabs must rest in one of the I-Beam bracket slots</p>

- Step 5. Slide wedge tabs in toward web of beam until two (2) M12 x 100 mm HHCS contact I-Beam flange sides. See Figure 3-24A.
- Step 6. Tighten bolts alternating between sides, until I-Beam bracket is tight, flush and centered across bottom of I-Beam. **Tighten until bolts are snug + 1/4 turn.**
- Step 7. Ensure I-beam bracket is perpendicular to I-beam lower flange. See Figure 3-24B below.
- Step 8. Tighten M10 x 30 mm HHCS rail mounting bracket bolts until lock washers are flat. Do not over tighten.
- Step 9. Install safety cable at each hanger location. Refer to this manual section "Safety Cabling" page 3-45.

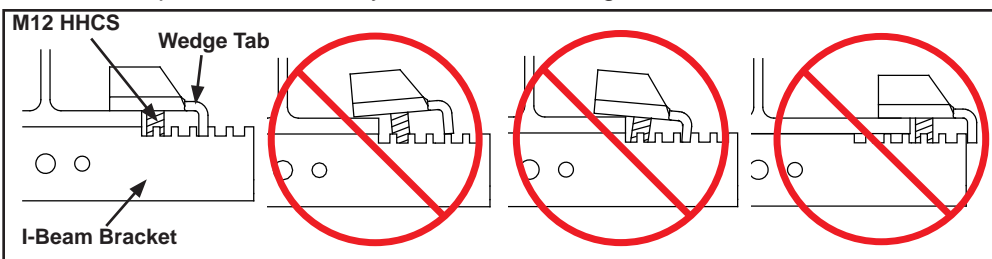

Figure 3-24A

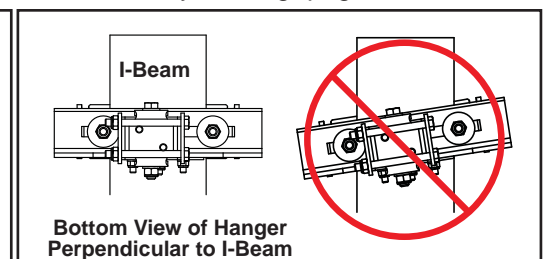

Figure 3-24B

Continued on next page.

HANGER INSTALLATION (CONTINUED)

Short Stack Parallel I-Beam Hanger (continued)

⚠ NOTE

Knight hanger systems are designed to pivot intentionally to allow for self alignment.

Leveling and Safeguarding

- Step 1. Verify rail pivots at hanger. M12 Pivot Bolt through hanger body should not be overtightened.
- Step 2. If leveling is required, loosen M12 x 100 mm HHCS , I-Beam bracket bolt and insert spacers, maximum 1/4 in (6 mm), between I-Beam bracket and bottom flange of I-Beam. See Figure 3-26.
- Step 3. Tighten M12 x 100mm HHCS until bolts are **snug + 1/4 turn**. Do not over tighten. Over tightening could cause bracket to bend.

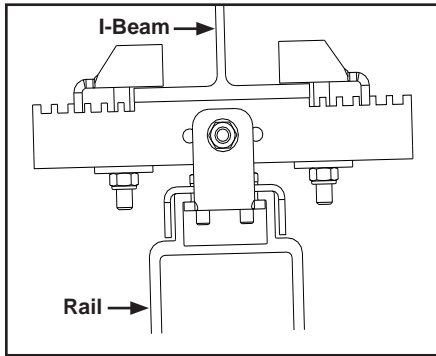

Figure 3-25

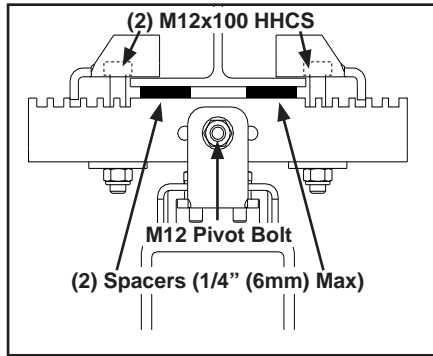

Figure 3-26

⚠ NOTE

The use of the supplied cross bolts are dictated by local safety regulations and specifications. Knight requires the use of the cross bolts when a hanger is centered over a rail splice.

Cross Bolts

- Step 1. Use rail mounting bracket as template to mark rail. See Figure 3-27.
- Step 2. Drill two (2) holes using 13/32 in (11 mm) drill bit. Do not attempt to drill holes in-line. See Figure 3-28.
- Step 3. Install two (2) M10 x 110 mm HHCS with M10 nylock nuts. **Tighten until bolts are snug + 1/4 turn**. Do not over tighten. Over tightening could cause bracket to bend. See Figure 3-29

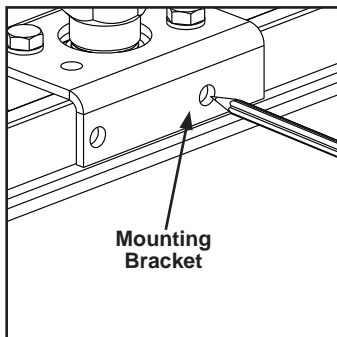

Figure 3-27

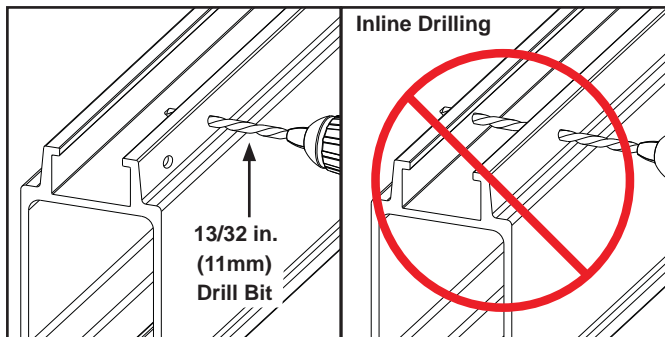

Figure 3-28

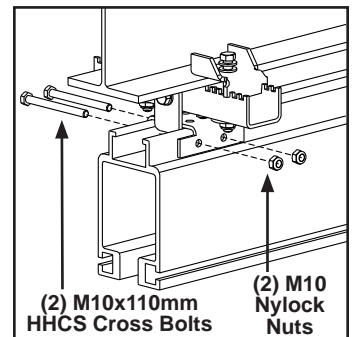



Figure 3-29

HANGER INSTALLATION (CONTINUED)

Short Stack Perpendicular I-Beam Hanger

Part Number(s): MRHS40771, MRHS40781

	WARNING
Use only fasteners provided by Knight Global. Do not use a system if end caps or stop assemblies are removed or damaged. All components must be installed according to instructions in this manual. All overhead attach points must have a safety cable installed according to manufacturer's instructions. Failure to comply may result in injury or death. Refer to page 2-3 for definition of "snug".	

	NOTE
Use hanger for direct loads only. Clamp sizes will fit structural steel I-Beam flanges from two (2) in to eleven (11) in (51 mm to 279 mm). Max I-Beam Flange thickness: 7/16" (Thicker flange beams will require modified hanger, available upon request).	

Installation

- Step 1. Remove cross bolts. Slide rail mounting bracket on top of the bracket channel and tap plate into bracket channel at top of runway rail. Position per system layout. See Figure 3-30.
- Step 2. Use a lift assist to raise hangers and rail into position.
- Step 3. Center I-Beam brackets on lower I-Beam flange. See Figure 3-31.

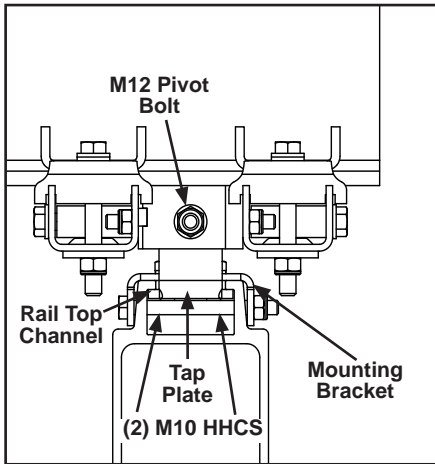

Figure 3-30

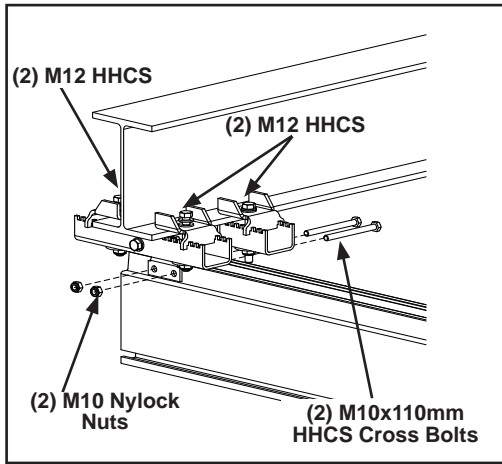

Figure 3-31

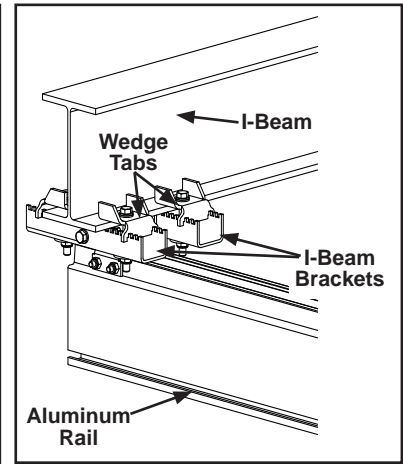



Figure 3-32

	NOTE
Wedge Tabs must rest in one of the I-Beam bracket slots	

- Step 4. Place wedge tabs on top of lower flange.
- Step 5. Slide wedge tabs on each bracket in toward web of beam until two (2) M12 x 100 mm HHCS contact I-Beam flange sides on each side of I-Beam. See Figure 3-33 below.
- Step 6. Tighten bolts alternating between sides, until I-Beam bracket is tight, flush and centered across bottom of I-Beam. **Tighten until bolts are snug + 1/4 turn.**
- Step 7. Ensure I-beam bracket is perpendicular to I-beam lower flange. See Figure 3-33B below.

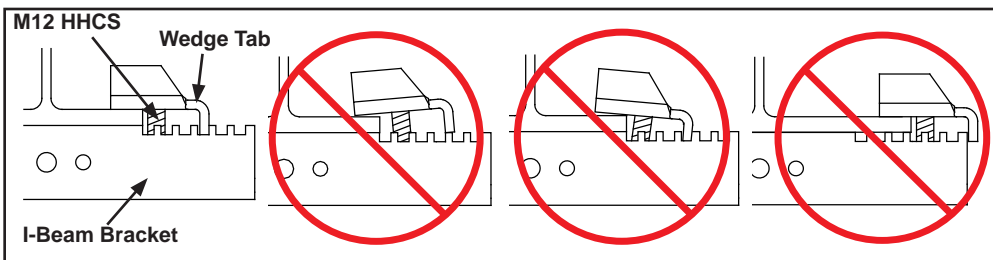

Figure 3-33A

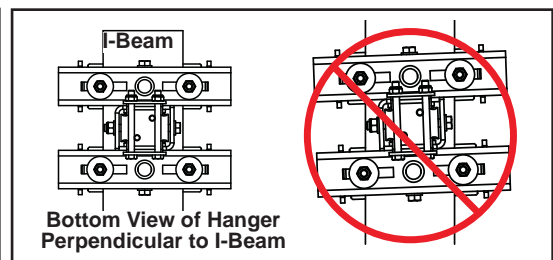

Figure 3-33B

Continued on next page.

HANGER INSTALLATION (CONTINUED)

Short Stack Perpendicular I-Beam Hanger (continued)

	NOTE
Knight hanger systems are designed to pivot intentionally to allow for self alignment.	

- Step 8. Tighten two (2) M10 x 30 mm HHCS until lock washers are flat to lock rail mounting bracket to rail. Do not over tighten.
- Step 9. Install safety cable at each hanger location. Refer to this manual section "Safety Cabling" page 3-45.

Leveling and Safeguarding

- Step 1. Verify rail pivots at hanger. Horizontal bolt through hanger body should not be overtightened.
- Step 2. If leveling is required, loosen M12 x 100 mm HHCS , I-Beam bracket bolt and insert spacers, maximum 1/4 in (6 mm), between I-Beam bracket and bottom flange of I-Beam. See Figure 3-35
- Step 3. Install two (2) M10 x 110 mm HHCS with M10 nylock nuts. **Tighten until bolts are snug + 1/4 turn.** Do not over tighten. Over tightening could cause bracket to bend.

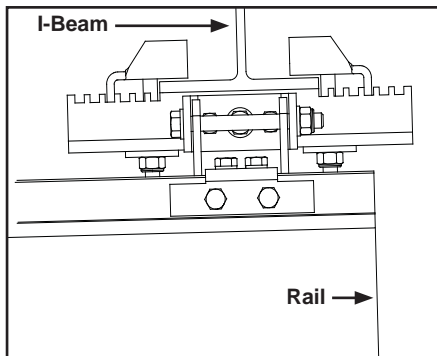

Figure 3-34

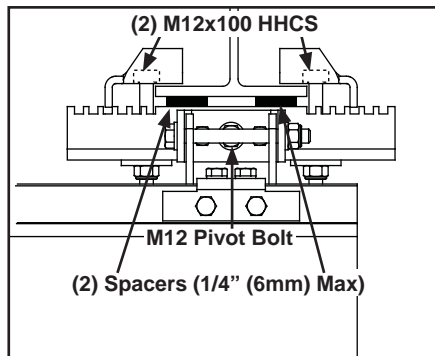



Figure 3-35

	NOTE
The use of the supplied cross bolts are dictated by local safety regulations and specifications. Knight requires the use of the cross bolts when a hanger is centered over a rail splice.	

Cross Bolts

- Step 1. Use rail mounting bracket as template to mark rail. See Figure 3-36
- Step 2. Drill two (2) holes using 13/32 in (11 mm) drill bit. Do not attempt to drill holes in-line. See Figure 3-37.
- Step 3. Install two (2) M10 x 110 mm HHCS with M10 nylock nuts. **Tighten until bolts are snug + 1/4 turn.** Do not over tighten. Over tightening could cause bracket to bend. See Figure Figure 3-38.

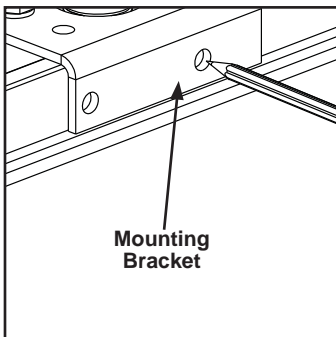

Figure 3-36

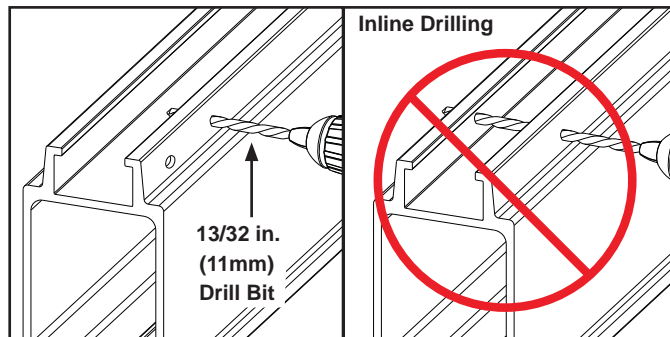

Figure 3-37

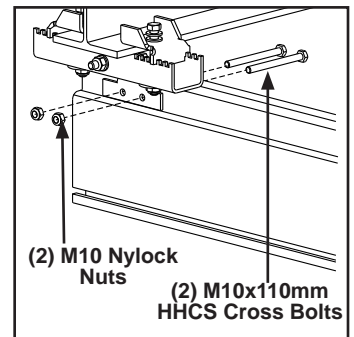



Figure 3-38

HANGER INSTALLATION (CONTINUED)

Rod and Ball C-Channel Hanger Installation

Part Number(s): TRH2034, MRHS4034

	WARNING
Use only fasteners provided by Knight Global. Do not use a system if end caps or stop assemblies are removed or damaged. All components must be installed according to instructions in this manual. All overhead attach points must have a safety cable installed according to manufacturer's instructions. Failure to comply may result in injury or death. Refer to page 2-3 for definition of "snug".	

	NOTE
Rod and Ball hangers are designed to be used for direct loads only.	

	CAUTION
Hanger is designed to use up to a 12 in. (304mm) threaded rod. Please consult with a Knight Global representative if a longer rod is required.	

Installation

- Step 1. Remove cross bolts. Slide rail mounting bracket on top of bracket channel and tap plate into bracket channel at top of runway rail. See Figure 3-39. Position per system layout.
- Step 2. Use a lift assist to raise hangers and rail into position.
- Step 3. Place C-Channel bracket on top of structural steel. See Figure 3-40.
- Step 4. Clamp wedge to structural steel, tightening M12 nylock nut on M12 x 100 mm HHCS. **Tighten until bolt is snug + 1/4 turn.** Do not over tighten. Over tightening could cause bracket to bend. See Figure 3-40.
- Step 5. Verify C-Channel bracket is tight to face and top flange of structural steel.

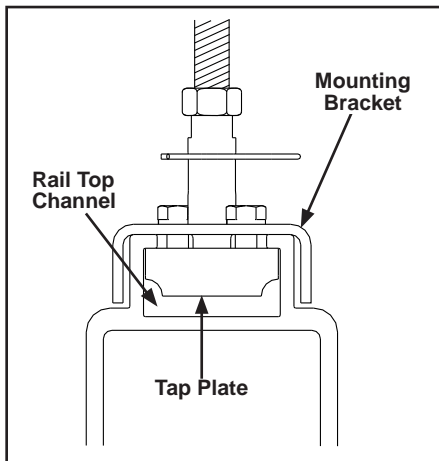

Figure 3-39

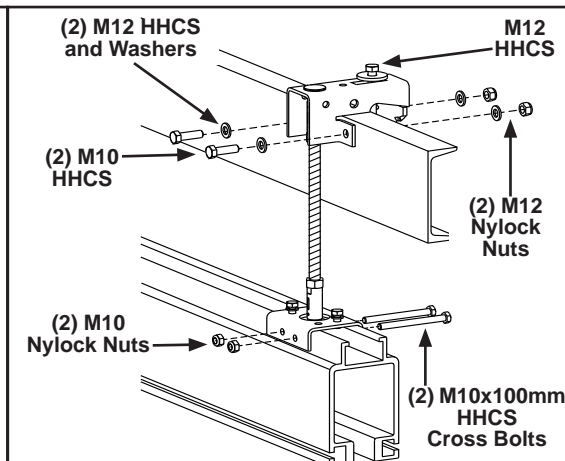

Figure 3-40

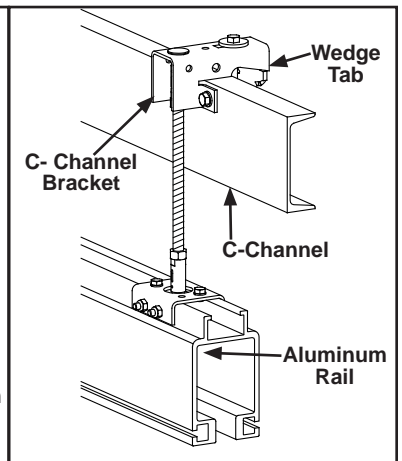

Figure 3-41

Continued on next page.

HANGER INSTALLATION (CONTINUED)

Rod and Ball C-Channel Hanger (continued)

Leveling And Safeguarding

	<p>WARNING</p>
<p>The spring clips and jam nuts are redundant safety features on this style hanger and MUST be used. All overhead attach points must have safety cable installed according to instructions in this manual. Failure to comply may result in injury or death.</p>	

- Step 1. Level rail according to system layout +/- 1/4 in.(6.4 mm). Use wrench flats to turn swivels for leveling. Refer to this manual section “Enclosed Track Rail Specs” page APPENDIX 1.
 - Turn counter clockwise to lower rail. Turn clockwise to raise rail.
- Step 2. Verify threads are visible in thread slots when finished leveling system. See Figure 3-42.
- Step 3. Loosen two (2) M10 x 30mm HHCS and tap C-Channel bracket or rail bracket lightly with a hammer until threaded rod is perpendicular to rail.
- Step 4. Tighten two (2) M10 x 30 mm HHCS until lock washers are flat to lock mounting bracket to rail. Do not over tighten.
- Step 5. Tighten M16 hex jam nuts to each rod connector to lock rod into connector. See Figure 3-43.
- Step 6. Drill into threaded rod through each thread slot with a 1/8 in (4 mm) drill bit and insert spring clips. See Figure 3-44.
- Step 7. Install safety cable. Refer to this manual section “Safety Cabling” page 3-40.

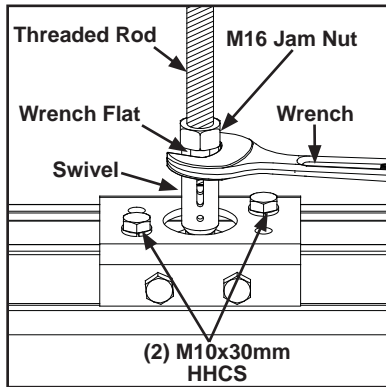

Figure 3-42

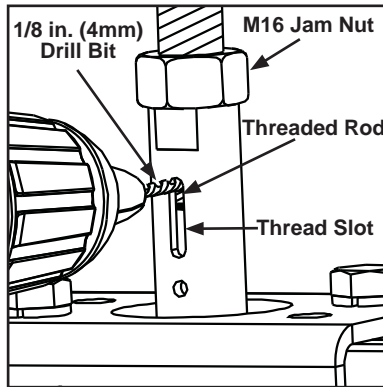

Figure 3-43

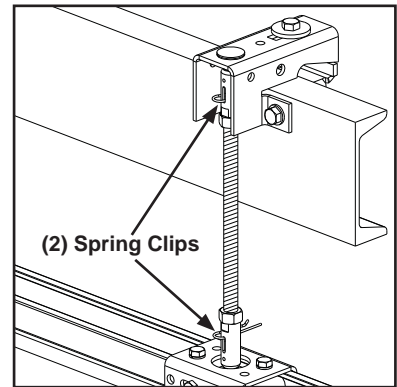



Figure 3-44

 <p>NOTE</p>	<p>The use of the supplied cross bolts are dictated by local safety regulations and specifications. Knight requires the use of the cross bolts when a hanger is centered over a rail splice.</p>
--	--

Cross Bolts

- Step 1. Use rail mounting bracket as template to mark rail. See Figure 3-45.
- Step 2. Drill two (2) holes using 13/32 in.(11 mm) drill bit. Do not attempt to drill holes in-line. See Figure 3-46.
- Step 3. Install two (2) M10 x 110 mm HHCS with M10 nylock nuts. **Tighten until bolts are snug + 1/4 turn.** Do not over tighten. Over tightening could cause bracket to bend. See Figure 3-47.

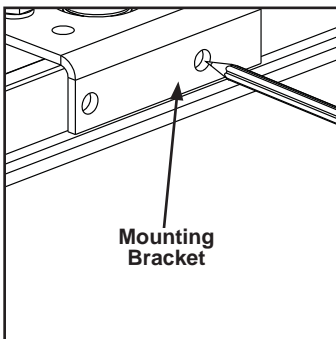

Figure 3-45

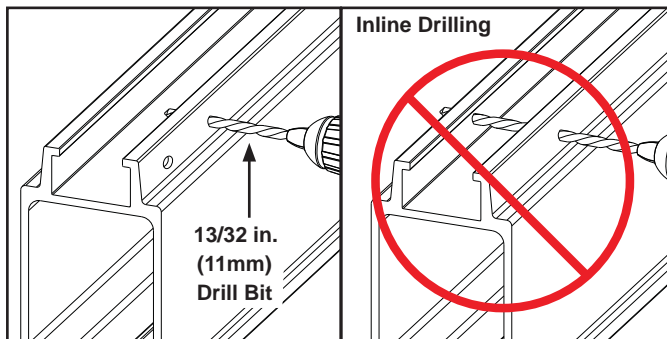

Figure 3-46

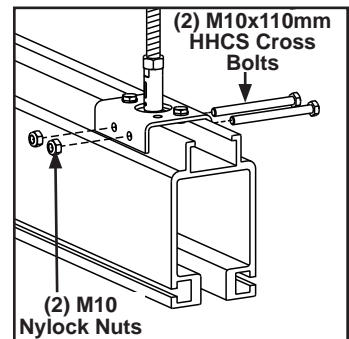

Figure 3-47

HANGER INSTALLATION (CONTINUED)

Sway Bracing Installation

Part Number(s): MRWS40161, MRWS41431

WARNING

Use only fasteners provided by Knight Global. All components must be installed according to instructions in this manual. All overhead attach points must have a safety cable installed according to manufacturer's instructions. Failure to comply may result in injury or death. Refer to page 2-3 for definition of "snug".

NOTE

Sway bracing is required, but not limited, on installations where hanger rod is longer than twenty-four (24) in (610 mm) and less than sixty (60) in (1524 mm).

NOTE

Additional structural steel may be needed for the attachment of brackets perpendicular to the runway.

- Step 1. Remove hanger bracket assembly by pulling spring clip and unscrewing female swivel from threaded rod.
- Step 2. Insert end of threaded rod through M16x1.5 hex nut, lower sway bar bracket, and M16x1.5 hex nut into the female swivel. See Figure 3-48.
- Step 3. Reassemble and insert spring clip into hanger bracket assembly.
- Step 4. Align the upper rod bracket with the I-Beam mounting bracket. See Figure 3-49.
- Step 5. Insert M10x30mm HHCS through (2) M10 washers, upper rod bracket, I-Beam mounting bracket and M10x1.5 hex nut. **Tighten until bolts are snug + 1/4 turn.** Do not over tighten. Over tightening could cause bracket to bend. See Figure 3-49.
- Step 6. Clamp I-Beam bracket with sway rod mounting bracket assembly to I-Beam adjacent to hanger to be braced. See Figure 3-49.
- Step 7. Place wedge tabs on top of lower flange of I-Beam.
- Step 8. Slide wedge tabs in toward web of beam until two (2) M12 x 100 mm HHCS contact I-Beam flange sides. See Figure 3-50A below.
- Step 9. Ensure I-beam bracket is perpendicular to I-beam lower flange. See Figure 3-50B below.

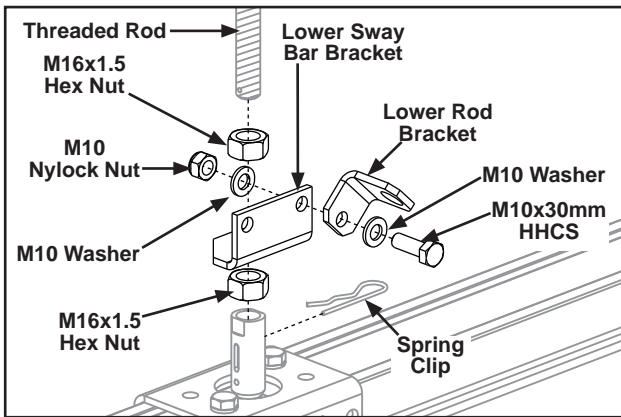

Figure 3-48

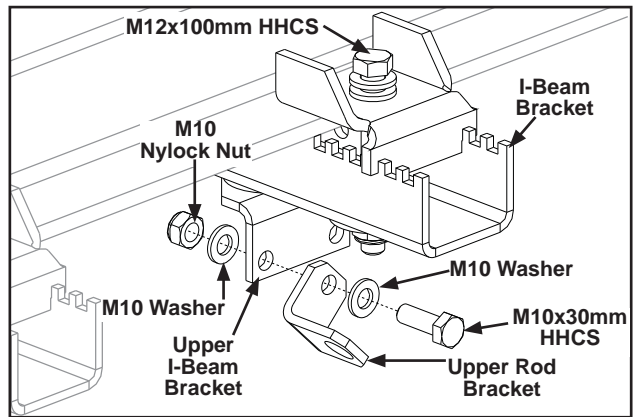

Figure 3-49

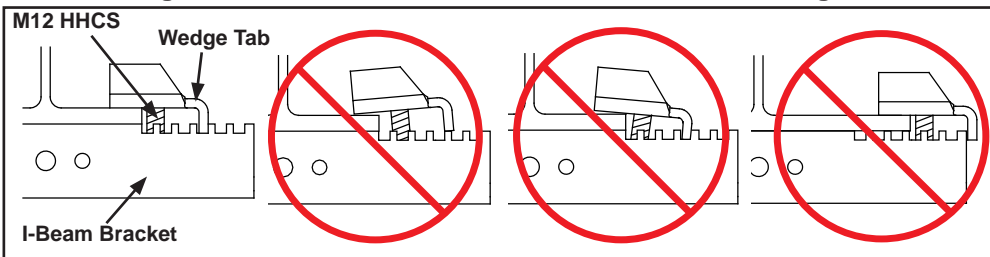

Figure 3-50A

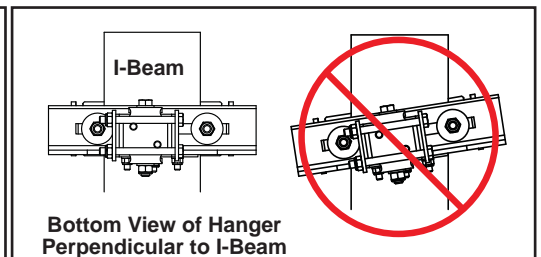

Figure 3-50B

Continued on next page.

Sway Bracing (continued)

- Step 10. Tighten (2) M12 x 100 mm HHCS, alternating between sides, until I-Beam bracket is tight but able to slide on the I-Beam for sway bar adjustments.
- Step 11. Insert threaded rod through lower rod bracket. Threaded rod should be at a 45° angle. See Figure 3-51.
- Step 12. Start two (2) M16 x 1.5 hex nuts on the threaded rod. See Figure 3-51
- Step 13. Insert rod end through the lower I-Beam rod bracket. See Figure 3-51.
- Step 14. Install two (2) M16 x 1.5 hex nuts on both ends. Tighten four (4) M16 x 1.5 hex nuts on threaded rod to brackets. See Figure 3-52.
- Step 15. Tighten two (2) M12 x 100 mm HHCS bolts on the sway bar brace I-Beam bracket, alternating between sides, until I-Beam bracket is tight. **Tighten until bolts are snug + ¼ turn.** Do not over tighten. Over tightening could cause bracket to bend. Do not over tighten. See Figure 3-52.

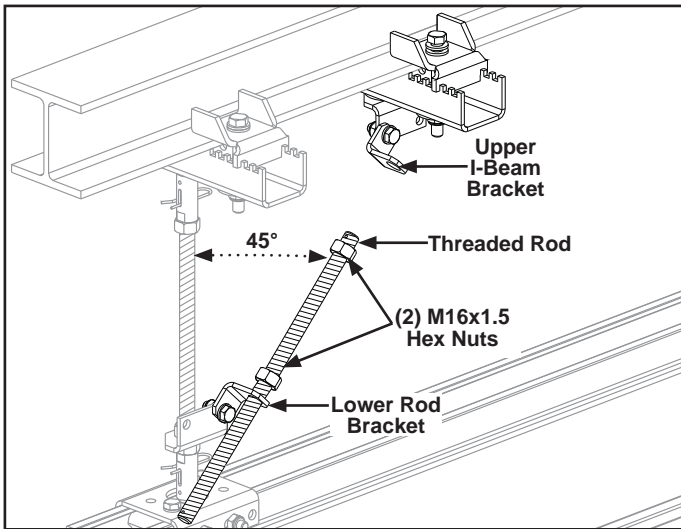

Figure 3-51

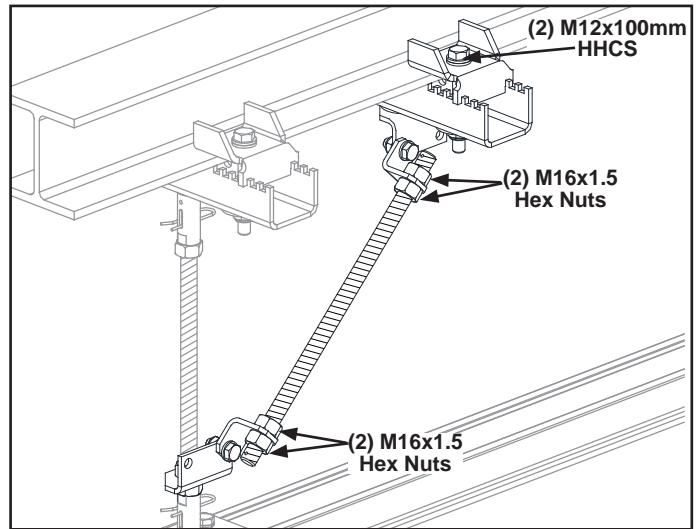



Figure 3-52

HANGER INSTALLATION (CONTINUED)

Rod and Ball Swivel I-Beam Hanger Installation

Part Number(s): TRH20361, TRH20431, MRHS40361, MRHS4043

 **WARNING**

Use only fasteners provided by Knight Global. Do not use a system if end caps or stop assemblies are removed or damaged. All components must be installed according to instructions in this manual. All overhead attach points must have a safety cable installed according to manufacturer's instructions. Failure to comply may result in injury or death. Refer to page 2-3 for definition of "snug".

 **NOTE**

Use hanger for direct loads only. Clamp sizes will fit structural steel I-Beam flanges from two (2) in to eleven (11) in (51 mm to 279 mm). Max I-Beam Flange thickness: **7/16"** (Thicker flange beams will require modified hanger, available upon request).

- Step 1. Remove cross bolts. Slide rail mounting bracket on top of bracket channel and tap plate into bracket channel at top of runway rail. Position per system layout. See Figure 3-53 through Figure 3-55.
- Step 2. Use a lift assist to raise hangers and rail into position.

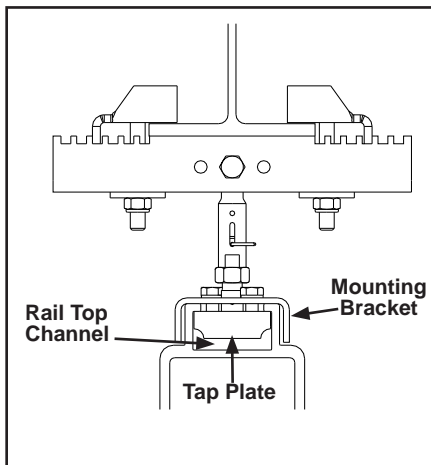

Figure 3-53

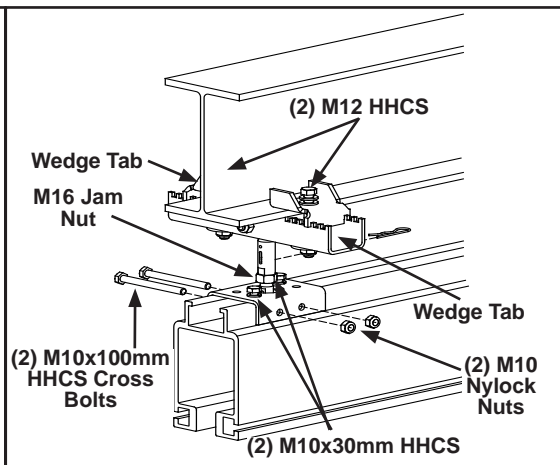

Figure 3-54

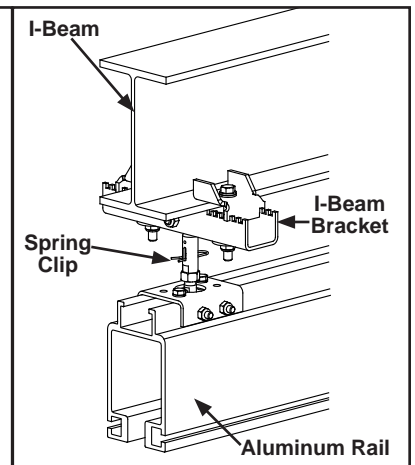



Figure 3-55

 **NOTE**

Wedge Tabs must rest in one of the I-Beam bracket slots.

- Step 3. Center I-Beam bracket on lower I-Beam flange.
- Step 4. Place wedge tab on top of lower flange. See Figure 3-56.
- Step 5. Slide wedge tabs in toward web of beam until wedges contact I-Beam flange sides. See Figure 3-56A below.
- Step 6. Tighten bolts alternating between sides, until I-Beam bracket is tight, flush and centered across bottom of I-Beam. **Tighten until bolts are snug + 1/4 turn.**
- Step 7. Ensure I-beam bracket is perpendicular to I-beam lower flange. See Figure 3-56B below.

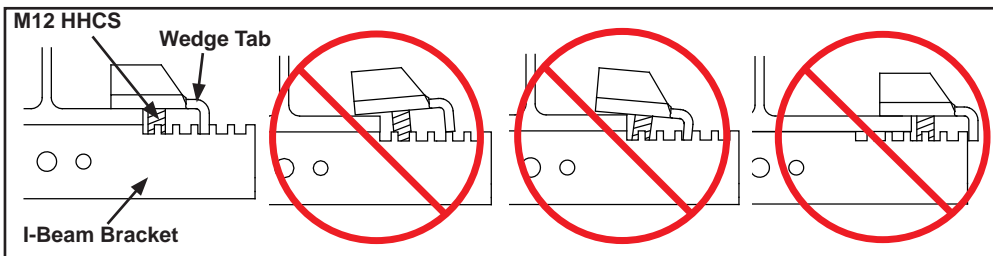

Figure 3-56A

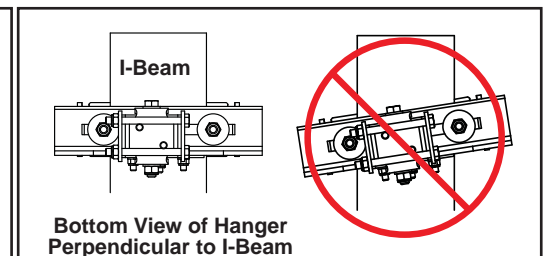

Figure 3-56B

Continued on Next page.

HANGER INSTALLATION (CONTINUED)

Rod and Ball Swivel I-Beam Hanger (continued)

	WARNING
<p>The spring clips and hex nut are redundant safety features on this style hanger and MUST be used. All components must be installed according to instructions in this manual. Failure to comply may result in injury or death.</p>	

Leveling And Safeguarding

- Step 1. Level rail according to system layout +/- 1/4 in.(6.4 mm). Use wrench flats to turn swivels for leveling. Refer to this manual section “Enclosed Track Rail Specs” page APPENDIX 1”.
 - Turn counter clockwise to lower rail. Turn clockwise to raise rail.
- Step 2. Verify threads are visible in thread slot when finished leveling system. See Figure 3-57.
- Step 3. Tap C-Channel bracket or rail bracket lightly with a hammer until threaded rod is perpendicular to rail.
- Step 4. Tighten two (2) M10 x 30 mm HHCS to lock mounting bracket to rail. Tighten bolts until lock washer is flat. Do not over tighten. See Figure 3-57
- Step 5. Tighten M16 hex jam nut to rod connector to lock rod into connector. See Figure 3-57.
- Step 6. Drill into threaded rod through thread slot with a 1/8 in (4 mm) drill bit and insert spring clip. See Figure 3-58 and Figure 3-59.
- Step 7. Install safety cable. Refer to this manual section “Safety Cabling” page 3-45.

Cross Bolts

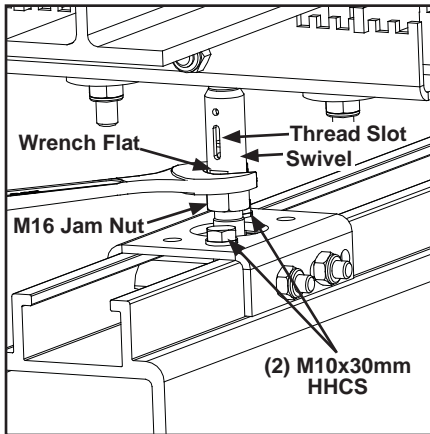

Figure 3-57

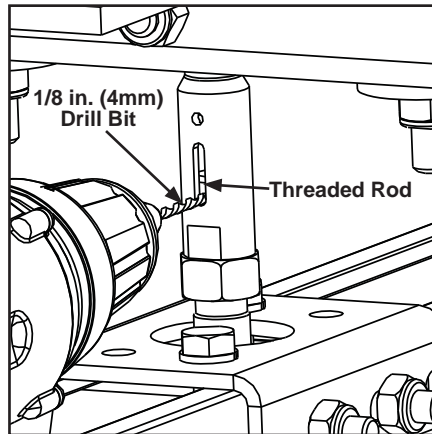

Figure 3-58

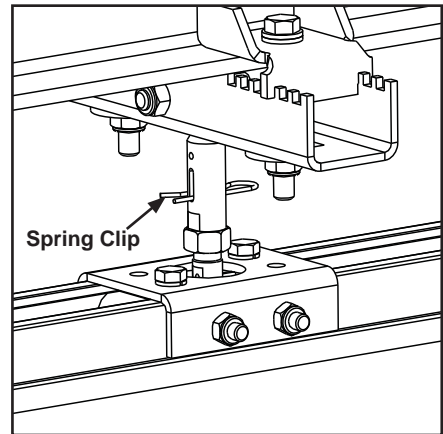



Figure 3-59

	NOTE
<p>The use of the supplied cross bolts are dictated by local safety regulations and specifications. Knight requires the use of the cross bolts when a hanger is centered over a rail splice.</p>	

- Step 1. Use rail mounting bracket as template to mark rail and drill two (2) holes using 13/32 in (11 mm) drill bit. Do not attempt to drill holes in-line. See Figure 3-60 and Figure 3-61.
- Step 2. Install two (2) M10 x 100 mm HHCS with M10 nylock nuts. **Tighten until bolts are snug + 1/4 turn.** Do not over tighten. Over tightening could cause bracket to bend. See Figure 3-62

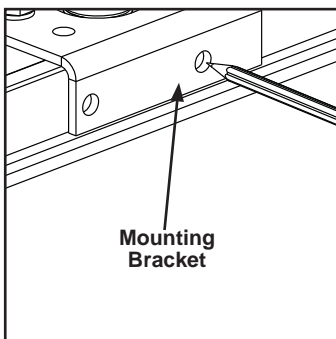

Figure 3-60

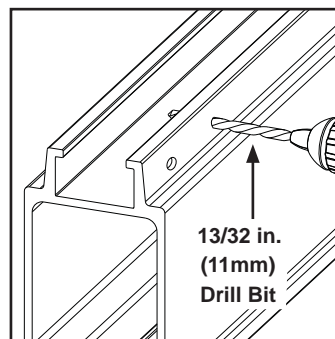

Figure 3-61

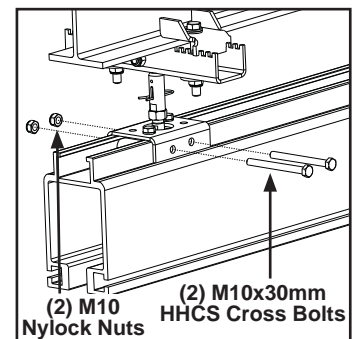
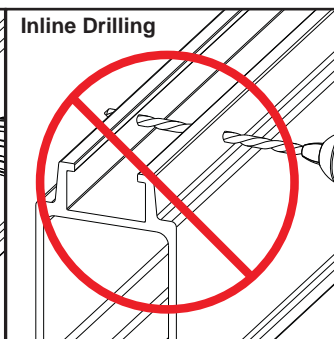



Figure 3-62

HANGER INSTALLATION (CONTINUED)

Extended Stack Rod and Ball Swivel I-Beam Hanger Installation

Part Number(s): TRH20471, TRH20511, MRHS40471, MRHS40511

	WARNING
<p>Use only fasteners provided by Knight Global. Do not use a system if end caps or stop assemblies are removed or damaged. All components must be installed according to instructions in this manual. All overhead attach points must have a safety cable installed according to manufacturer's instructions. Failure to comply may result in injury or death. Refer to page 2-3 for definition of "snug".</p>	

	NOTE
<p>Use hanger for direct loads only. Clamp sizes will fit structural steel I-Beam flanges from two (2) in to eleven (11) in (51 mm to 279 mm). Max I-Beam Flange thickness: 7/16" (Thicker flange beams will require modified hanger, available upon request).</p>	

	CAUTION
<p>Sway bracing is required, but not limited, on installations where hanger rod is longer than twenty-four (24) in (610 mm) and less than sixty (60) in (1524 mm).</p>	

Step 1. Remove cross bolts. Slide rail mounting bracket on top of bracket channel and tap plate into bracket channel at top of runway rail. Position per system layout. See Figure 3-63 and Figure 3-64.

Step 2. Use a lift assist to raise hangers and rail into position.

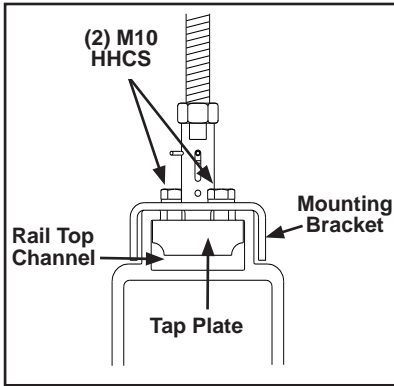

Figure 3-63

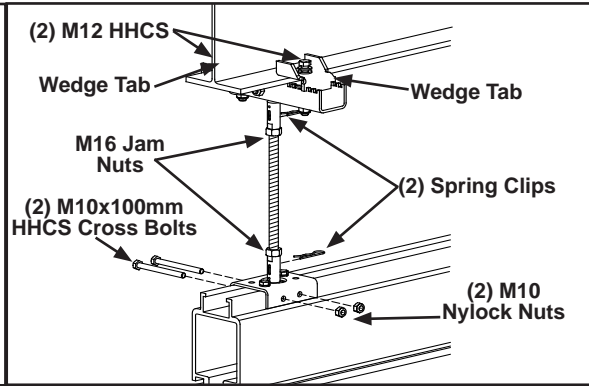

Figure 3-64

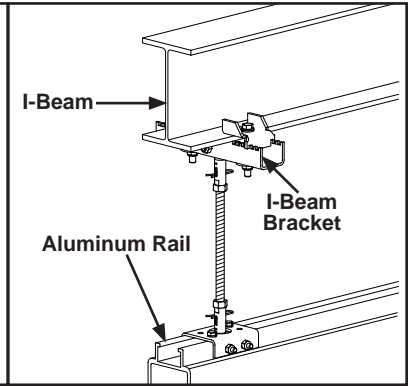



Figure 3-65

	NOTE
<p>Wedge Tabs must rest in one of the I-Beam bracket slots.</p>	

Step 3. Center I-Beam bracket on lower I-Beam flange. See Figure 3-65.

Step 4. Place wedge tab on top of lower flange. See Figure 3-66.

Step 5. Slide wedge tabs in toward web of beam until wedges contact I-Beam flange sides. See Figure 3-66A below.

Step 6. Tighten bolts alternating between sides, until I-Beam bracket is tight, flush and centered across bottom of I-Beam. **Tighten until bolts are snug + 1/4 turn.**

Step 7. Ensure I-beam bracket is perpendicular to I-beam lower flange. See Figure 3-66B below.

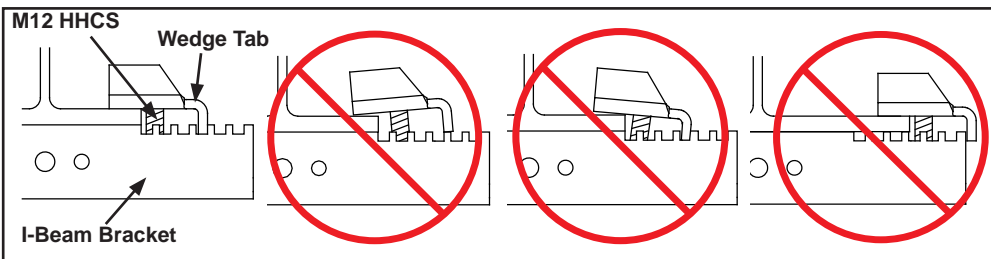

Figure 3-66A

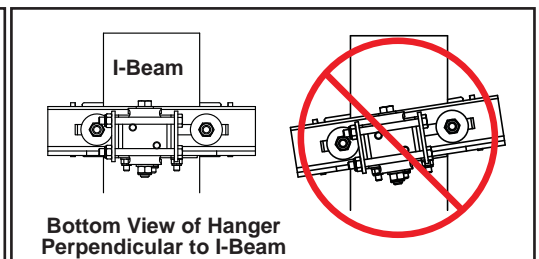

Figure 3-66B

Continued on next page.

HANGER INSTALLATION (CONTINUED)

Extended Stack Rod and Ball Swivel I-Beam Hanger (continued)

Leveling And Safeguarding

- Step 1. Level rail according to system layout +/- 1/4 in.(6.4 mm). Use wrench flats to turn swivels for leveling. Refer to this manual section “Enclosed Track Rail Specs” page APPENDIX 1.
 - Turn counter clockwise to lower rail. Turn clockwise to raise rail.
- Step 2. Verify threads are visible in thread slots when finished leveling system. See Figure 3-67.
- Step 3. Tap C-Channel bracket or rail bracket lightly with a hammer until threaded rod is perpendicular to rail.
- Step 4. Tighten two (2) M10 x 30 mm HHCS to lock mounting bracket to rail. Tighten bolts until lock washer is flat. Do not over tighten. See Figure 3-67.
- Step 5. Tighten M16 hex jam nuts to each rod connector to lock rod into connector. See Figure 3-67.
- Step 6. Drill into threaded rod through each thread slot with a 1/8 in (4 mm) drill bit and insert spring clips. See Figure 3-68 and Figure 3-69.
- Step 7. Install safety cable. Refer to this manual section “Safety Cabling” page 3-45.

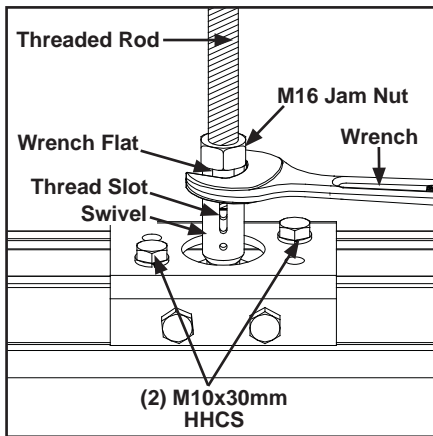

Figure 3-67

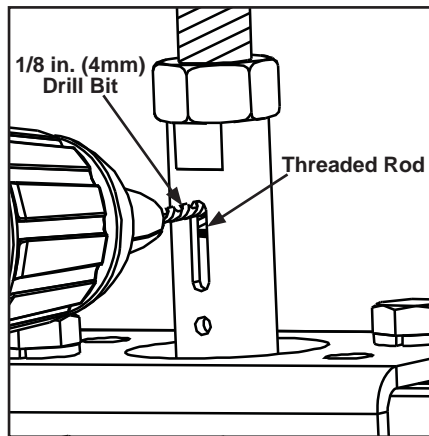

Figure 3-68

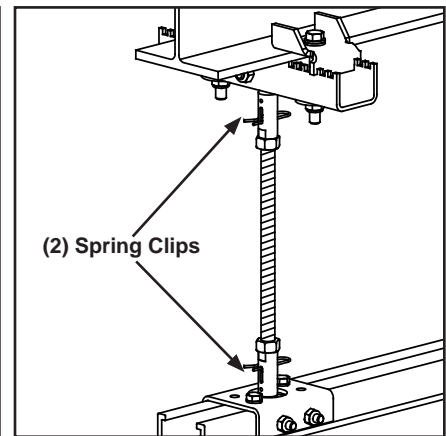

Figure 3-69

Cross Bolts

	NOTE
<p>The use of the supplied cross bolts are dictated by local safety regulations and specifications. Knight requires the use of the cross bolts when a hanger is centered over a rail splice.</p>	

- Step 1. Use rail mounting bracket as template to mark rail. See Figure 3-70
- Step 2. Drill two (2) holes using 13/32 in (11 mm) drill bit. Do not attempt to drill holes in-line. See Figure 3-71.
- Step 3. Install two (2) M10 x 100 mm HHCS with M10 nylock nuts. **Tighten until bolts are snug + 1/4 turn.** Do not over tighten. Over tightening could cause bracket to bend. See Figure 3-72.

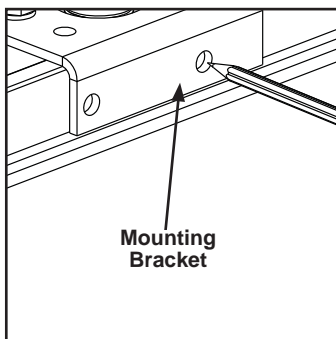

Figure 3-70

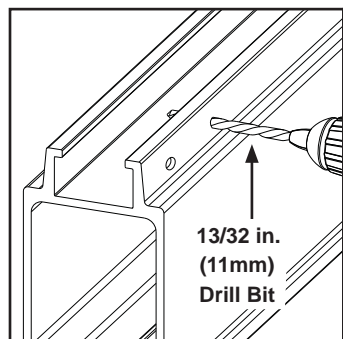

Figure 3-71

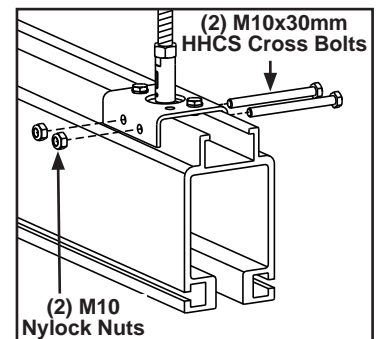
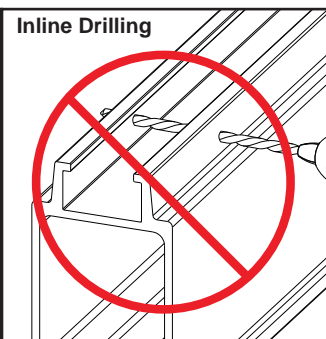

Figure 3-72

SPLICE KIT INSTALLATION

Part Number(s): TRS2067, MRHA4445, MRHA4485, MRHA7503, MRHA7585



WARNING

Use only fasteners provided by Knight Global. All components must be installed according to instructions in this manual. Failure to comply may result in injury or death. Refer to page 2-3 for definition of “snug”.

For RAD 7510, RAD 6110 and RAD 4110 series aluminum rail hanger location is based on rail layout and application i.e., there should be a hanger either directly over or within 18” of either side of splice. Each section of rail must be supported by at least two (2) hangers. (A splice is not considered a hanger.) Refer to Appendix page A-5 for figure of correct and incorrect hanger position.

- Step 1. Remove cross bolts. Slide top rail mounting bracket on top of bracket channel and tap plate into bracket channel at top of rail. Position per system layout. See Figure 3-73.
- Step 2. Place rails to be spliced end to end to ensure they are square to each other and exhibit no gaps.
- Step 3. Separate rails for splice installation.
- Step 4. Slide top rail mounting bracket and tap plate together. Ensure tap plate is below lip of bracket channel. See Figure 3-74.
- Step 5. Slide one side splice bar into each splice slot located on bottom of each side of rail.
- Step 6. Place second rail square to rail with splice bracket and splice bars.
- Step 7. Center top rail mounting bracket directly over splice.
- Step 8. Tighten two (2) M10 x 30 mm HHCS on top rail mounting bracket to align and secure two (2) rails. Tighten bolts until lock washer is flat. Do not over tighten.
- Step 9. Center two (2) side splice bars over splice.
- Step 10. Tighten eight (8) M8 x 30 mm HHCS on side splice bars. Tighten bolts until lock washer is flat. Do not over tighten. Verify splice joint has no gaps. See Figure 3-75.
- Step 11. Use top rail mounting bracket as template to mark rail and drill two (2) holes using 13/32 in (11 mm) drill bit. Do not attempt to drill holes in-line.
- Step 12. Install two (2) M10 x 110 mm HHCS with M10 nylock nuts. **Tighten until bolts are snug + ¼ turn.** Do not over tighten. Over tightening could cause bracket to bend.

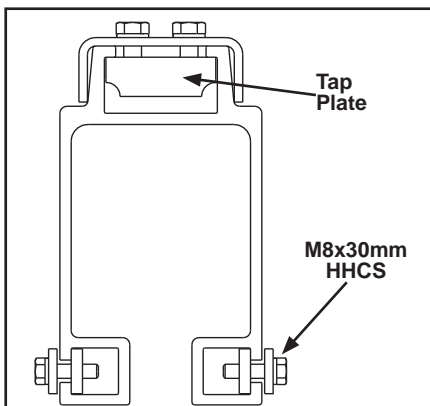

Figure 3-73

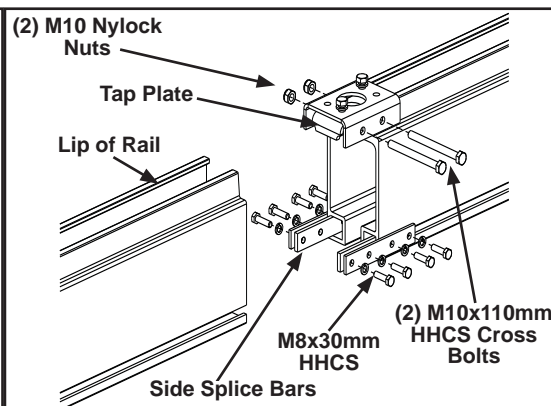

Figure 3-74

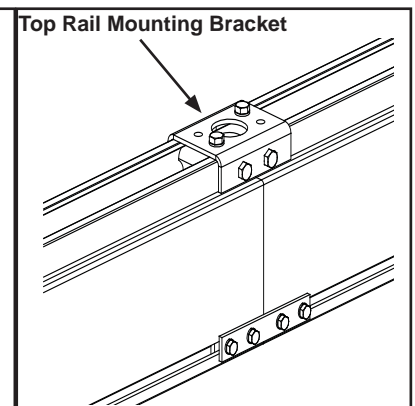



Figure 3-75



END CAPS AND STOPS INSTALLATION

End Cap Part Number(s): TRN2016, MRAA4011, MRAA6104, MRAA4804

End Cap (w/shock) Part Number(s): MRAA4462, MRAA6105, MRAA4805

	 WARNING
	<p>Use only fasteners provided by Knight Global. Do not use a system if end caps or stop assemblies are removed or damaged. All components must be installed according to instructions in this manual. All overhead attach points must have a safety cable installed according to manufacturer's instructions. Failure to comply may result in injury or death. Refer to page 2-3 for definition of "snug".</p>

	 CAUTION
	<p>An end cap and mid rail stop combination is to be used as a redundant stop assembly. End cap should not be used as a primary stop.</p>

	 NOTE
	<p>MRAA6104 (six inch) and MRAA4804 (eight inch) end caps have bosses to prevent overtightening.</p>

End Cap Installation

- Step 1. Determine end of rail that needs to be capped by locating pre-drilled end cap holes.
- Step 2. Install M10 x 110 mm HHCS, M10 nylock nuts, and M10 flat washers. **Tighten all end cap bolts until bolts are snug + 1/4 turn.** Do not over tighten. See Figure 3-76 for end cap models.

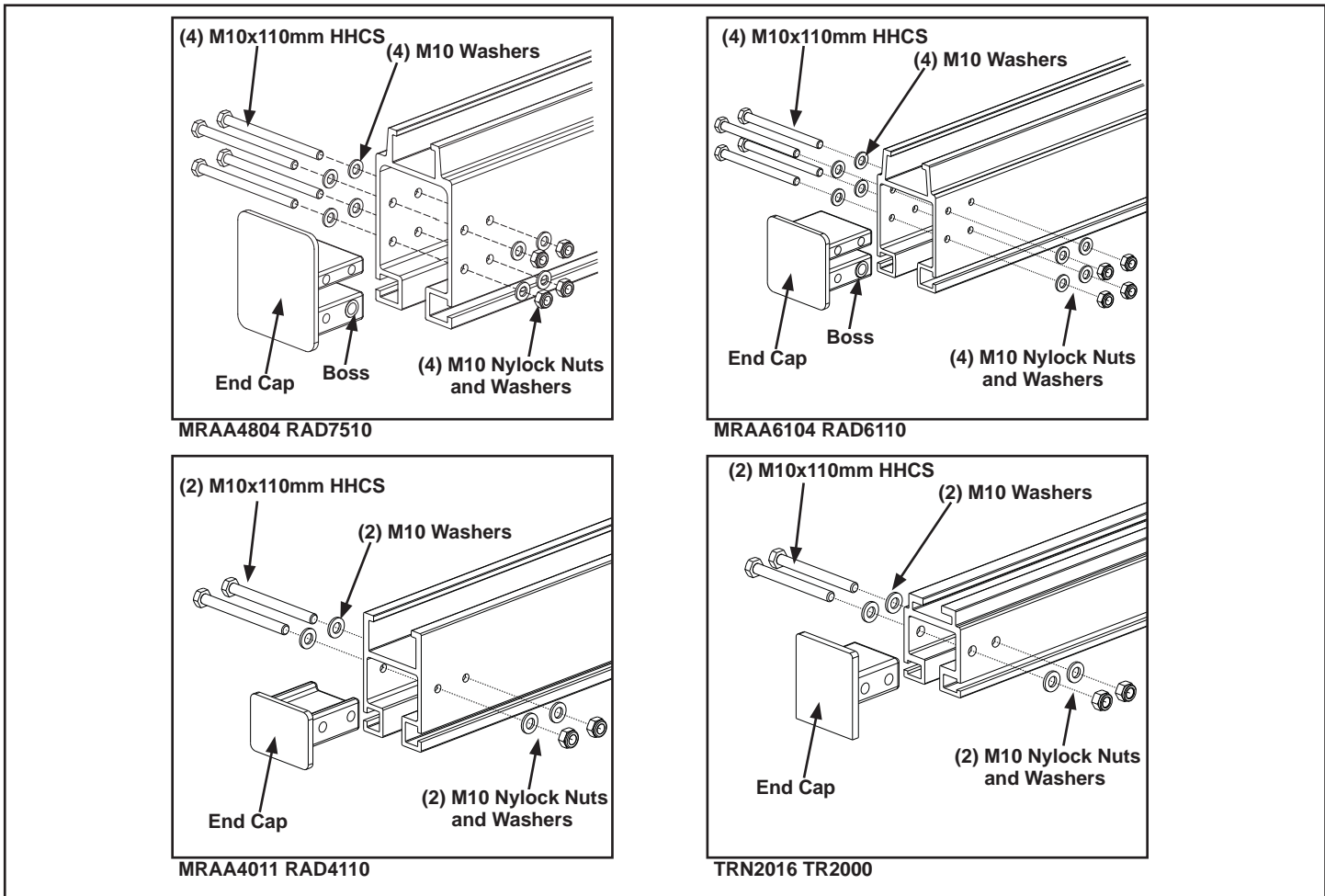

Figure 3-76

Redundant Stop and Mid Rail Stop Installation

Redundant Stop Part Number(s): TRN2114, MRAS4454, MRAS6133, MRAS7533

Mid Rail Stop Part Number(s): TRA2070, MRAA4455, MRAA6111, MRAA7511

Mid Rail Stop (w/shock) Part Number(s): MRAA4243, MRAA6022, MRA7022

- Step 1. Verify rubber bumper faces load. See Figure 3-77 Redundant Stop. Loosen cage nut with stop tab until flush with end of bolt.
- Step 2. Go to step **2a** for **Redundant stop** (installation) or step **2b** for **Mid Rail Stop** (installation).
- a. Redundant Stop :** Insert cage nut with stop tab into bottom rail slot near end cap. Tighten M12 x 80 mm HHCS, on bottom until secure. Tightening will turn trapping stop tab until it engages inner side wall, capturing stop inside rail. Attach lanyard to any end cap bolt. **Tighten all end cap bolts until bolts are snug + ¼ turn.** Do not over tighten. Over tightening could cause bracket to bend.
- b. Mid Rail Stop:** Insert cage nut with tab into bottom rail slot, per system layout. Tighten M12 x 80 mm HHCS until secure. Tightening will turn stop tab until it engages inner side wall, capturing stop inside rail. Attach lanyard to either M10x150mm cross bolt. **Tighten all bolts until bolts are snug + ¼ turn.** Do not over tighten.

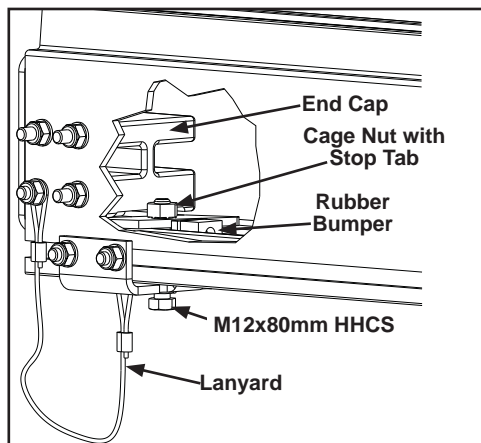

Figure 3-77 Redundant Stop

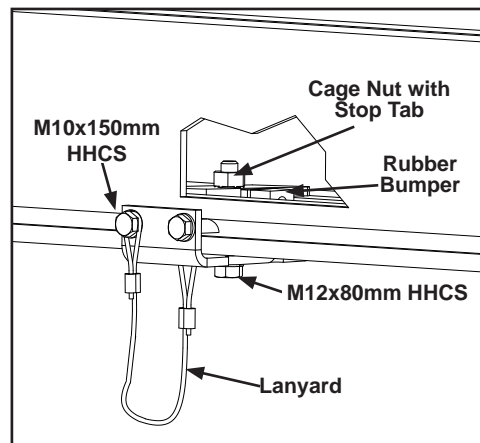



Figure 3-78 Mid Rail Stop

TROLLEYS

Balancer Trolley

Part Number(s): TRT2001, MRTA4001, MRTA6106, MRTA7706

	⚠ WARNING
	<p>Use only fasteners provided by Knight Global. Do not use a system if end caps or stop assemblies are removed or damaged. All components must be installed according to instructions in this manual. All overhead attach points must have a safety cable installed according to manufacturer's instructions. Failure to comply may result in injury or death. Refer to page 2-3 for definition of "snug".</p>

Installation

Step 1. Slide two (2) M16 x 100 mm HHCS with M16 washers through the air bracket and on one side of can bracket. See Figure 3-79.

	⚠ NOTE
	<p>Air bracket must be installed on same side of air supply inlet. See Figure 3-44</p>

Step 2. Sandwich trolley with spacers inside balancer bracket by sliding one (1) 5/8 in (16 mm) x 1 in (25 mm) spacer on each bolt and slide bolts through mounting holes on trolley. See Figure 3-79.

Step 3. Install two (2) remaining spacers, one (1) per bolt, between trolley and second plate on can bracket.

Step 4. Install two (2) M16 x 2.0 nylock nuts and M16 flat washers onto mounting bolts.

Step 5. Tighten nylock nuts until **snug and verify bolts do not rotate by hand**. Do not over tighten bolts.

Step 6. Install safety cable. Refer to this manual section "Safety Cabling" page 3-45.

Step 7. Remove end cap and stop assemblies from rail. Refer to this manual section "End Caps and Stops" page 3-20.

Step 8. Wipe rolling surfaces of rail with a clean dry rag.

Step 9. Roll trolley into rail. See Figure 3-80.

Step 10. Reinstall end cap and stop assemblies. Refer to this manual section "End Caps and Stops" page 3-20.

	⚠ CAUTION
	<p>Do not over-tighten fasteners. Stress from over-tightening will cause damage to the can bracket.</p>

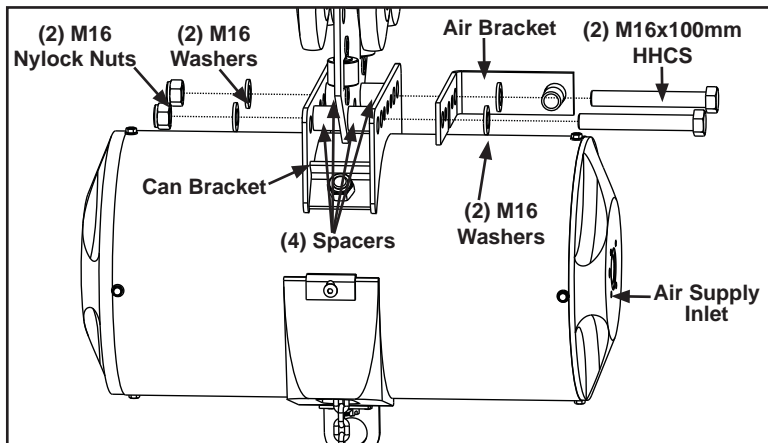

Figure 3-79

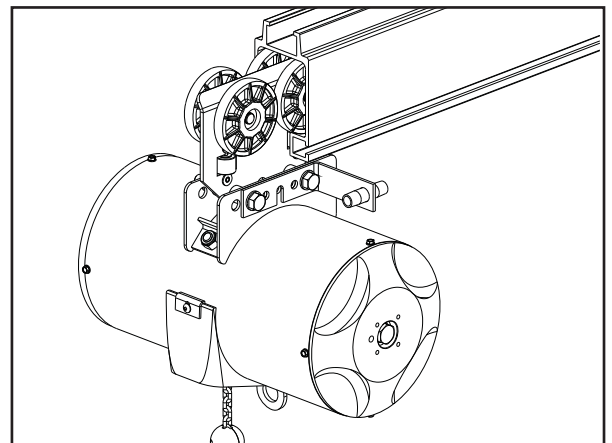

Figure 3-80

TROLLEY INSTALLATION (CONTINUED)

Boss Trolley

Part Number(s): TRT2002, MRTA4003, MRTA4312, MRTA6102, MRTA7002, MRTA7765

Yoke Trolley

Part Number(s): MRTA4009, MRTA4266, MRTA6123, MRTA7723, MRTA7786

Eye Hook Trolley

Part Number(s): TRT2003, MRTA4029, MRTA4393, MRTA6119, MRT7719, MRTA7787

**WARNING**

Use only fasteners provided by Knight Global. Do not use a system if end caps or stop assemblies are removed or damaged. All components must be installed according to instructions in this manual. All overhead attach points must have a safety cable installed according to manufacturer's instructions. Failure to comply may result in injury or death. Refer to page 2-3 for definition of "snug".

Installation

- Step 1. Slide M16 x 150 mm HHCS pivot bolt through bosses and item to be suspended.
- Step 2. Tighten nylock nuts until **snug and verify bolts do not rotate by hand**. Do not over tighten bolts.
- Step 3. Install safety cable. Refer to this manual section "Safety Cabling" page 3-45.
- Step 4. Remove end cap and stop assemblies from rail.
- Step 5. Wipe rolling surfaces of rail with a clean dry rag.
- Step 6. Roll trolley into trolley channel.
- Step 7. Reinstall end cap and stop assemblies according to instructions. Refer to this manual section "End Caps and Stops" page 3-20.

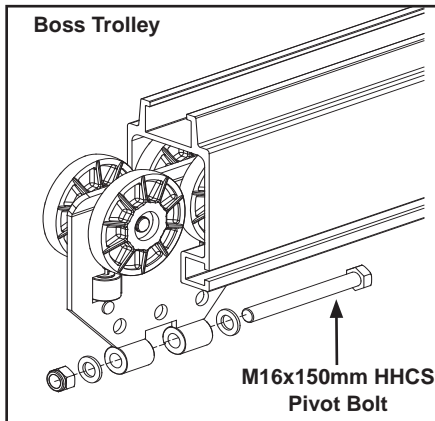

Figure 3-81

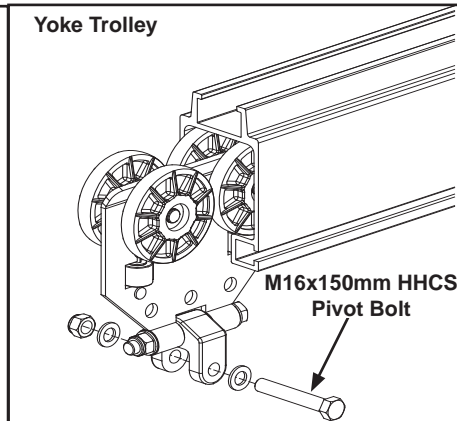

Figure 3-82

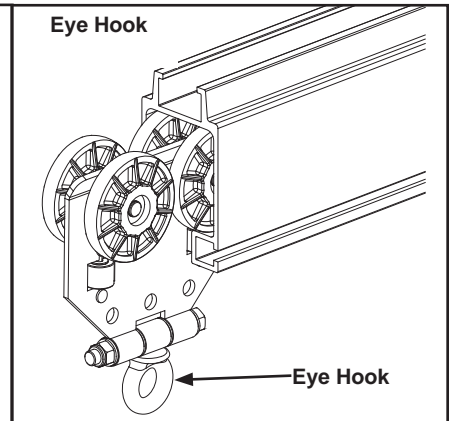

Figure 3-83

END TRUCKS

Pivoting End Truck

Single Bridge End Truck

Part Number(s): TRE2025, MRES4025, MRES4310, MRES6128, MRES7728, MRES7904
Dual Bridge End Truck

Part Number(s): MRES4072, MRES4311, MRES6117, MRES7717, MRES7903
Dual Trolley Single or Dual Bridge End Trucks

Part Number(s): MRES4073, MRES6118, MRES7718

	⚠ WARNING
Use only fasteners provided by Knight Global. Do not use a system if end caps or stop assemblies are removed or damaged. All components must be installed according to instructions in this manual. All overhead attach points must have a safety cable installed according to manufacturer's instructions. Failure to comply may result in injury or death. Refer to page 2-3 for definition of "snug".	

	⚠ NOTE
Knight Global End Trucks are designed to pivot and self align themselves.	

	⚠ NOTE
Ensure cable is properly installed on end truck. If removed, cable must be replaced with approved cable and clips.	

Installation

- Step 1. Single, dual, and special order bridges are supplied pre-assembled. If bridge is not pre-assembled, assemble according to plan layout.
- Step 2. Place safety cable along bottom of mounting bracket that is attached to trolley. Install safety cable. Refer to this manual section "Safety Cabling" page 3-45.
- Step 3. Remove cross bolts. Slide rail mounting bracket on top of bracket channel and tap plate into bracket channel at top of bridge rail. Position per system layout.
- Step 4. Use a lift assist to raise hangers and rail into position. See Figure 3-84.
- Step 5. Position end truck on bridge according to system layout and tighten two (2) M10 x 30 mm HHCS to clamp end trucks in place. Tighten bolts until lock washer is flat. Do not over tighten.
- Step 6. Repeat steps 2 through 5 for other side of bridge.

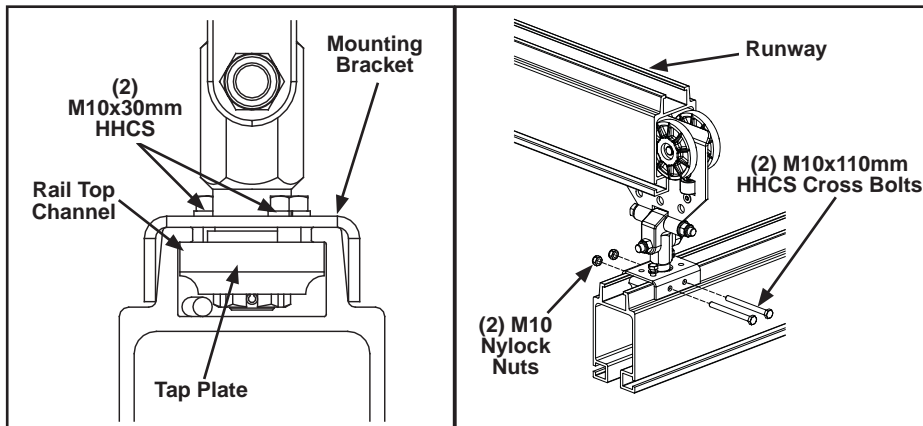

Figure 3-84

Figure 3-85

- Step 7. Remove end cap and stop assemblies from rail.
- Step 8. Wipe rolling surfaces of rail with a clean dry rag.
- Step 9. Raise bridge and roll end trucks into runway.

Continued on next page.

END TRUCK INSTALLATION (CONTINUED)

Pivoting End Trucks Installation (continued)

- Step 10. Reinstall end cap and stop assemblies according to instructions. Refer to this manual section “End Caps and Stops” page 3-20.
- Step 11. If centering adjustment is needed, loosen two (2) M10 x 30 mm HHCS and lightly tap end truck bracket with a hammer to match runway center to center.
- Step 12. **Tighten until bolts are snug + ¼ turn.** Do not over tighten. Over tightening could cause bracket to bend. Check bridge travel along runway. Repeat until bridge travels smoothly.

NOTE

The use of the supplied cross bolts are dictated by local safety regulations and specifications. Knight requires the use of the cross bolts when a hanger is centered over a rail splice.

Cross Bolts

- Step 1. Use rail mounting bracket as template to mark rail. See Figure 3-86.
- Step 2. Drill two (2) holes using 13/32 in (11 mm) drill bit. Do not attempt to drill holes in-line. See Figure 3-87.
- Step 3. Install two (2) M10 x 100 mm HHCS with M10 nylock nuts. **Tighten until snug.** See Figure 3-88.

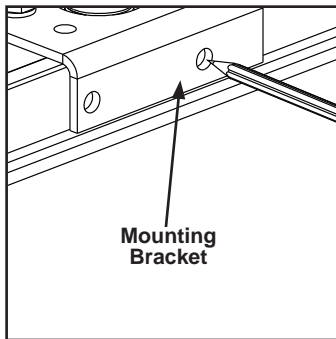

Figure 3-86

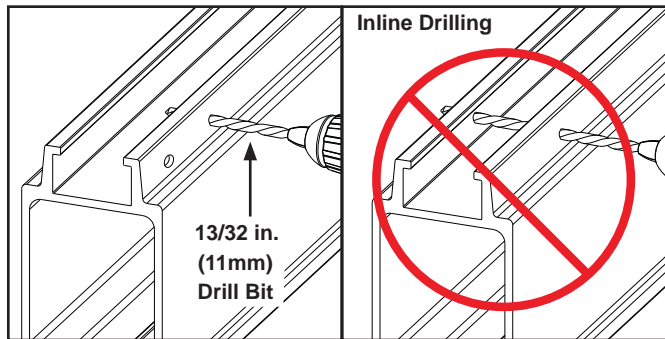

Figure 3-87

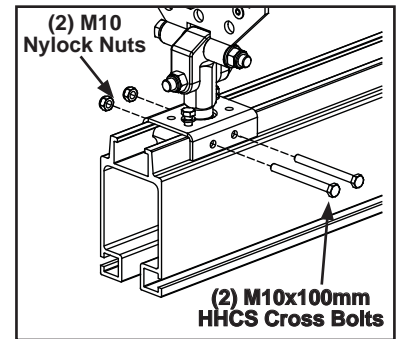

Figure 3-88

Assembly for TRE2025 only

- Step 1. Single, dual, and special order bridges are supplied pre-assembled. If bridge is not pre-assembled, assemble according to plan layout.
- Step 2. Insert safety cable through two (2) tab holes on tap plate and through a hole in the trolley plate.
- Step 3. Slide rail mounting bracket and the two (2) side mounting bars on the sides of the rail while also sliding the tap plate into top bracket channel at top of bridge rail. Position per system layout. See Figure 3-89.
- Step 4. Use a lift assist to raise hangers and rail into position. See Figure 3-90.
- Step 5. Position end truck on bridge according to system layout and tighten two (2) M8 x 20 mm HHCS for the tap plate and the four (4) M6 x 20 mm HHCS on the two (2) side mounting bars to clamp end trucks in place. **Tighten until bolts are snug + ¼ turn.** Do not over tighten. Over tightening could cause bracket to bend.
- Step 6. Repeat steps 2 through 5 for other side of bridge.

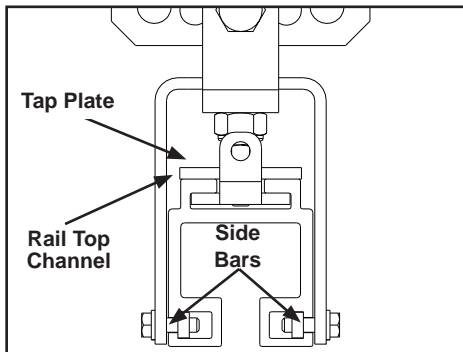

Figure 3-89

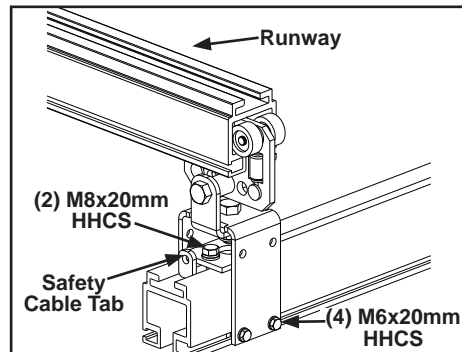

Figure 3-90

END TRUCK INSTALLATION (CONTINUED)

Rigid Single or Dual Bridge Rigid End Truck

Part Number(s): MRES4226, MRES6135, MRES7735

**WARNING**

Use only fasteners provided by Knight Global. Do not use a system if end caps or stop assemblies are removed or damaged. All components must be installed according to instructions in this manual. All overhead attach points must have a safety cable installed according to manufacturer's instructions. Failure to comply may result in injury or death. Refer to page 2-3 for definition of "snug".

Installation

- Step 1. Remove cross bolts from the three (3) mounting brackets and slide rail mounting brackets on top of bracket channel and the three (3) tap plates into bracket channel at top of runway rail. See Figure 3-91 and Figure 3-92.
- Step 2. Position end truck on bridge according to system layout.
- Step 3. Tighten two (2) M10 x 30 mm HHCS and nylock nut on each of three (3) mounting brackets. Tighten bolts until lock washer is flat. Do not over tighten. See Figure 3-93
- Step 4. Repeat steps 1 through 3 for opposite side of bridge.
- Step 5. Remove end cap and stop assemblies from runway rail.
- Step 6. Wipe rolling surfaces of rail with a clean dry rag.
- Step 7. Raise bridge and roll end trucks into runway.
- Step 8. Reinstall end cap and stop assemblies according to instructions. Refer to this manual section "End Caps and Stops" page 3-20.
- Step 9. If centering adjustment is needed, loosen three (3) M10 x 30 mm HHCS and nylock nuts, tap end truck bracket to match runway center to center.
- Step 10. Tighten bolts and check bridge travel along runway. Repeat until bridge travels smoothly.
- Step 11. Install safety cable. Refer to this manual section "Safety Cabling" page 3-45.

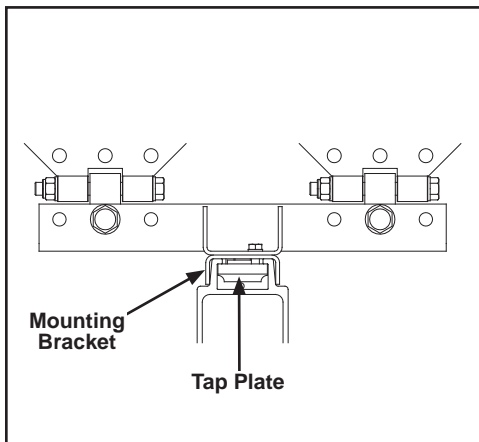

Figure 3-91

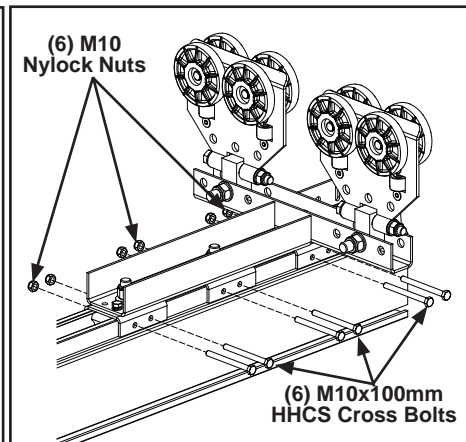

Figure 3-92

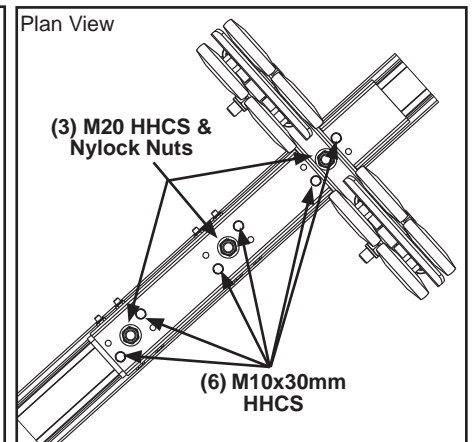

Figure 3-93

Continued on next page.

END TRUCK INSTALLATION (CONTINUED)

Rigid End Trucks Installation (continued)

Cross Bolts

- Step 1. Use rail mounting bracket as template to mark rail. See Figure 3-94.
- Step 2. Drill two (2) holes using 13/32 in (11 mm) drill bit. Do not attempt to drill holes in-line. See Figure 3-95.
- Step 3. Install two (2) M10 x 100 mm HHCS with M10 nylock nuts. **Tighten until bolts are snug + ¼ turn.** Do not over tighten. Over tightening could cause bracket to bend. See Figure 3-96.

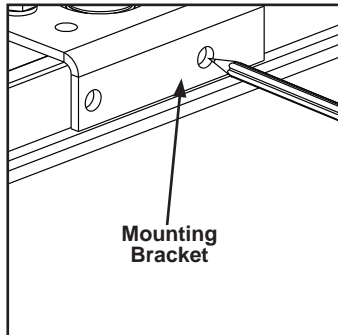

Figure 3-94

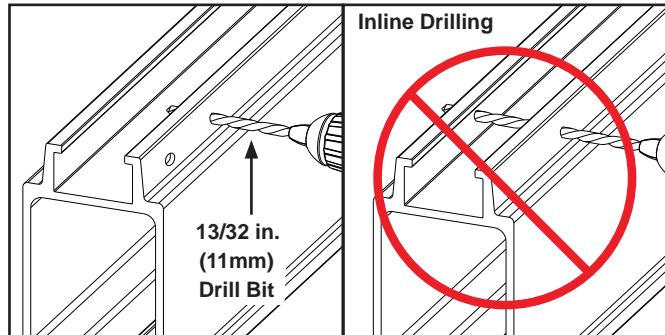

Figure 3-95

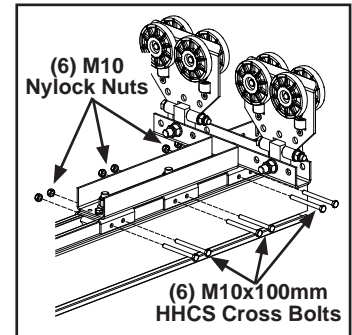

Figure 3-96

END TRUCK INSTALLATION (CONTINUED)

Same Plane Single or Dual Bridge End Truck

Part Number(s): MRES4476, MRES6174, MRES7528

Same Plane Single or Dual Bridge Pivoting End Truck

Part Number(s): MRES4472, MRES7575

**WARNING**

Use only fasteners provided by Knight Global. Do not use a system if end caps or stop assemblies are removed or damaged. All components must be installed according to instructions in this manual. All overhead attach points must have a safety cable installed according to manufacturer's instructions. Failure to comply may result in injury or death. Refer to page 2-3 for definition of "snug".

INSTALLATION

- Step 1. Slide three (3) tap plates and mounting bracket assemblies into bracket channel. See Figure 3-97.
- Step 2. Insert two (2) splice block assemblies into bottom channels of rail with tapped hole facing end of rail.
- Step 3. Place same plane assembly over two (2) 3/4 - 10 bolts pointing up from mounting bracket assemblies.
- Step 4. Tap same plane end truck assembly with a rubber mallet until flush with end of rail.
- Step 5. Verify slotted holes in vertical end of same plane end truck assembly line up with splice slots.
- Step 6. Install two (2) M10 x 30 mm HHCS into tapped holes in splice blocks on face of bracket. **Tighten until snug.** See Figure 3-97.
- Step 7. Secure tap plate assemblies to rail by tightening six (6) M10 x 30 mm HHCS at top of rail. Tighten bolts until lock washer is flat. Do not over tighten See Figure 3-98.
- Step 8. Install two (2) 3/4 nylock nuts onto two (2) 3/4 bolts on top of end truck body. Tighten nylock nuts until **snug**, verify bolts do not rotate by hand, do not over tighten bolts.

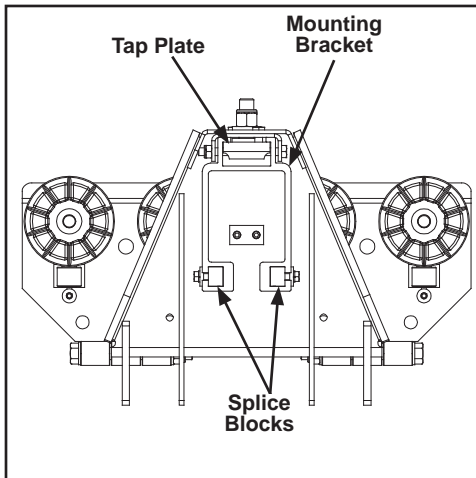

Figure 3-97

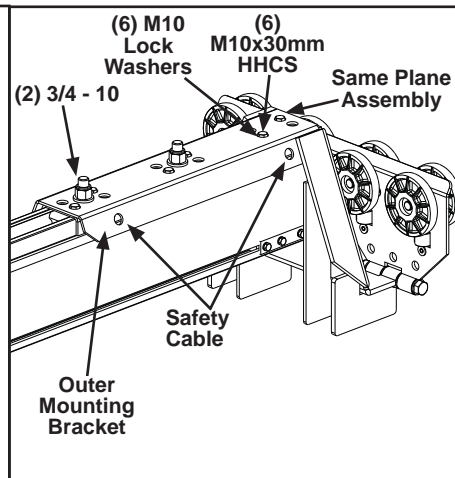

Figure 3-98

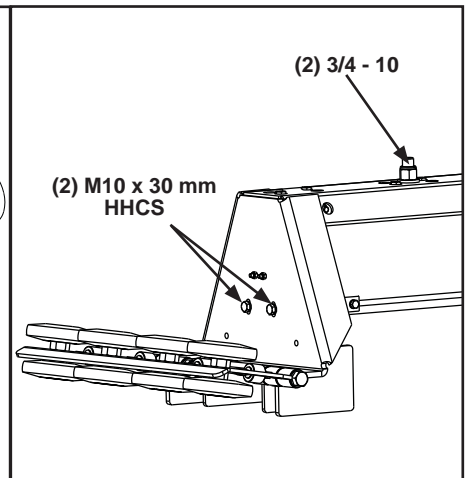

Figure 3-99

Continued on next page.

Same Plane End Truck Installation (continued)

Step 9. Using same plane end truck body as a guide drill four (4) 13/32 in (11 mm) holes in top of rail through bracket channel at two (2) outer mounting brackets. See Figure 3-100 and Figure 3-101. Do not drill in-line.

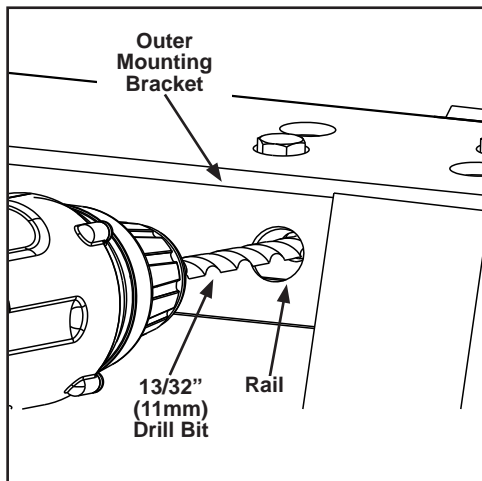

Figure 3-100

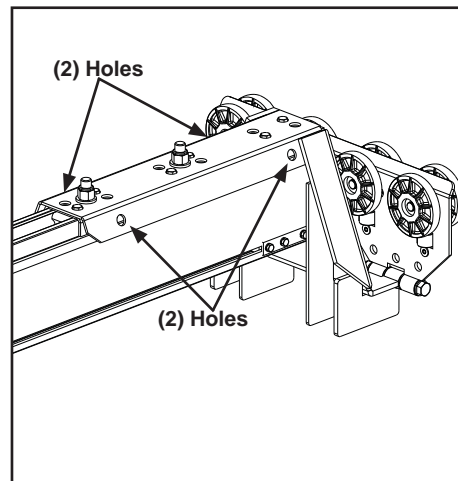

Figure 3-101

Step 10. Safety cable end truck body to rail using two (2) outside holes of outer mounting bracket. See Figure 3-134 on page 3-47. Refer to this manual section "Safety Cabling" page 3-45.

Step 11. !!! IMPORTANT !!! Insert trolley that will run inside bridge prior to installing same plane end truck assembly on other end of bridge.

Step 12. Repeat steps 1-11 for opposite end of bridge runway rail.

**NOTE**

Integral Access Gates are required on all same plane bridge installations.

Step 13. Remove end cap and stop assemblies from rail.

Step 14. Wipe rolling surfaces of rail with a clean dry rag.

Step 15. Verify trolley centers match runway centers. If matches don't exist, the runway must be moved.

Step 16. Raise bridge and roll end trucks into runway.

Step 17. Reinstall end cap and stop assemblies according to instructions. Refer to this manual section "End Caps and Stops" page 3-20.

Step 18. Install safety cable. Refer to this manual section "Safety Cabling" page 3-45.

ACCESSORIES

Hose Trolley

Part Number(s): MRMA4019, MRMA6114, MRMA4814

	⚠ WARNING
	<p>Use only fasteners provided by Knight Global. Do not use a system if end caps or stop assemblies are removed or damaged. All components must be installed according to instructions in this manual. All overhead attach points must have a safety cable installed according to manufacturer's instructions. Failure to comply may result in injury or death. Refer to page 2-3 for definition of "snug".</p>

	⚠ NOTE
	<p>One hose trolley is used per five (5) ft (1524 mm) of rail. Verify hose loops hang down from trolley with a length of approximately three (3) ft (914 mm). Refer to this manual section "Festooned Hose Management Kit" page 3-32.</p>

	⚠ NOTE
	<p>Hose trolleys are ordered separately from hose management kits.</p>

	⚠ CAUTION
	<p>Ensure that there are no obstructions for the hose to get snagged on.</p>

Installation

- Step 1. Remove end cap and stop assemblies from rail.
- Step 2. Roll Hose Trolleys into open end of rail, alternating direction the U-bolt faces on every other trolley. See Figure 3-102 and Figure 3-103.
- Step 3. Reinstall end cap and stop assemblies. Refer to this manual section "End Caps and Stops" page 3-20.

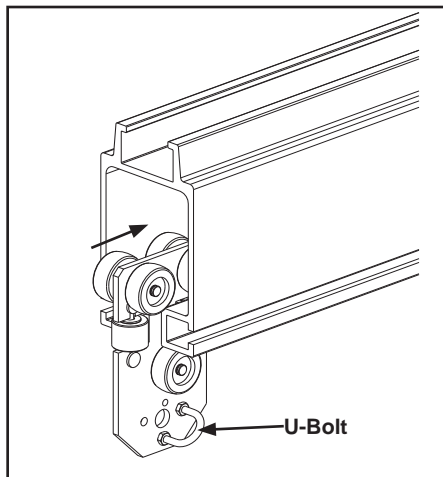

Figure 3-102

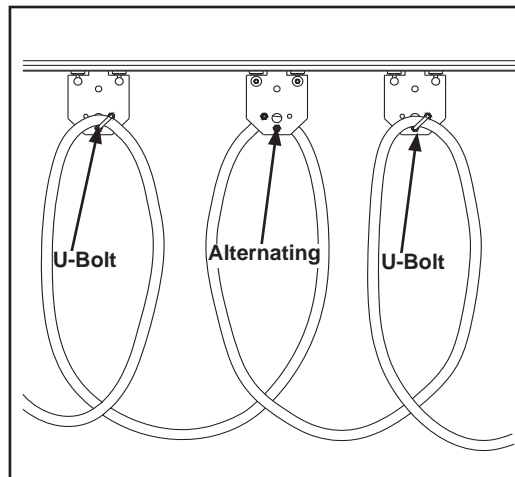





Figure 3-103

ACCESSORIES (CONTINUED)

Hose Trolley with Cable Saddle

Part Number(s): MRMA4215, MRMA6115, MRMA4815

	<p style="text-align: center;">⚠ WARNING</p>
	<p style="text-align: center;">⚠ NOTE</p>
	<p style="text-align: center;">⚠ NOTE</p>
	<p style="text-align: center;">⚠ CAUTION</p>
<p>Use only fasteners provided by Knight Global. Do not use a system if end caps or stop assemblies are removed or damaged. All components must be installed according to instructions in this manual. All overhead attach points must have a safety cable installed according to manufacturer's instructions. Failure to comply may result in injury or death. Refer to page 2-3 for definition of "snug".</p> <p>Average cable length is five (5) ft. (1524 mm) of cable per cable saddle. Verify hose loops hang down from trolley with a length of approximately three (3) ft. (914 mm).</p> <p>Hose trolleys are ordered separately from hose management kits.</p> <p>Ensure that there are no obstructions for the hose to get snagged on.</p>	

Installation

- Step 1. Install hose trolleys in rail.
- Step 2. Drape cables/hoses on saddles. Adjust the size of the loop and tighten Velcro straps. See Figure 3-105.
- Step 3. Reinstall end cap and stop assemblies. Refer to this manual section "End Caps and Stops" page 3-20.

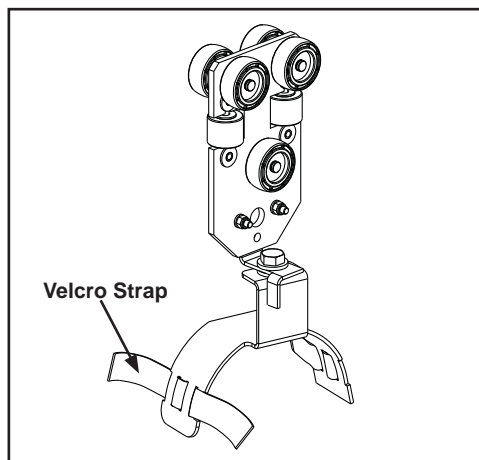

Figure 3-104

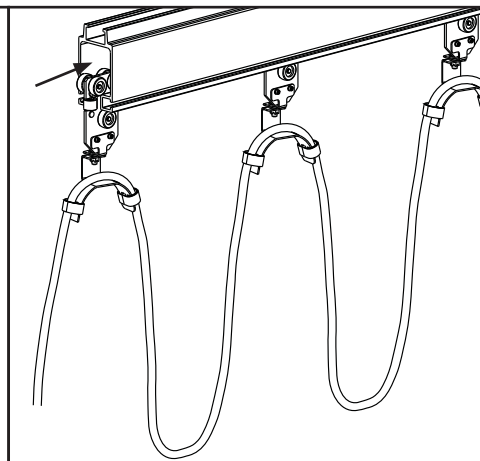

Figure 3-105

ACCESSORIES (CONTINUED)

Festooned Hose Management Kit

Part Number(s): MRMS4201

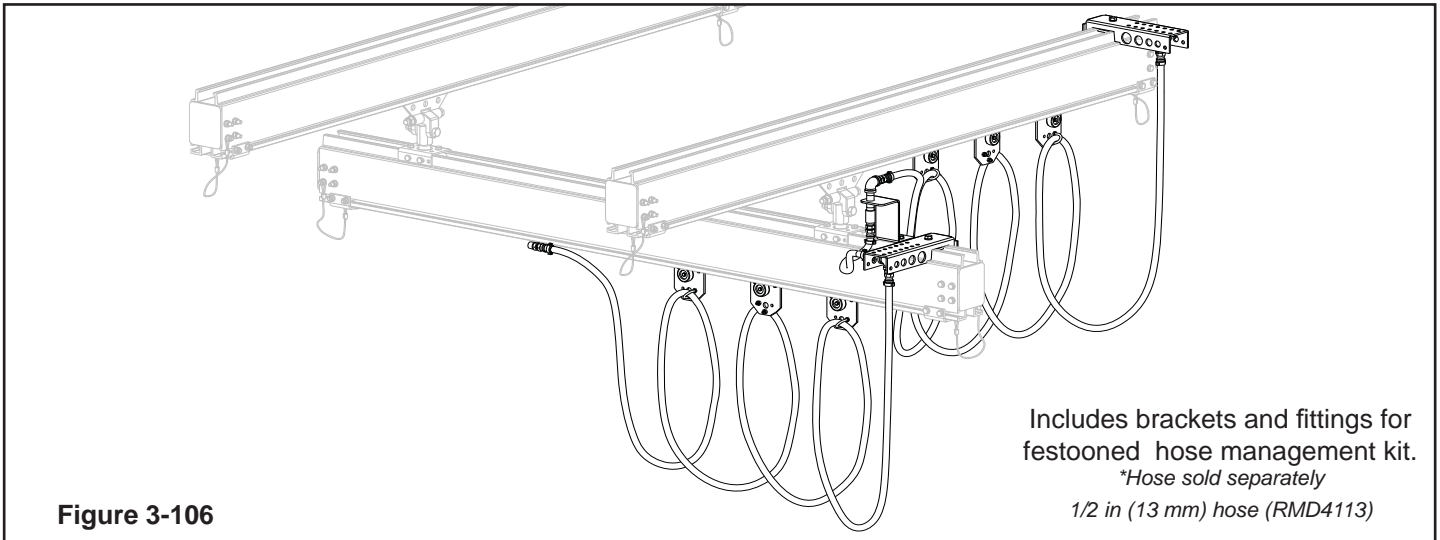





Figure 3-106

Includes brackets and fittings for festooned hose management kit.
 *Hose sold separately
 1/2 in (13 mm) hose (RMD4113)

	 WARNING
<p>Use only fasteners provided by Knight Global. Do not use a system if end caps or stop assemblies are removed or damaged. All components must be installed according to instructions in this manual. All overhead attach points must have a safety cable installed according to manufacturer's instructions. Failure to comply may result in injury or death. Refer to page 2-3 for definition of "snug".</p>	

	 NOTE
<p>All Knight products require clean, dry air only. Use thread sealant on all pipe threaded fittings, do not tape or "dope" 37° fittings.</p>	

INSTALLATION

Festoon Hose Installation To Runway Rail

- Step 1. Start at runway rail end closest to plant air supply. Attach rail support bracket by loosening cage nut and sliding rail support bracket into rail top channel. See Figure 3-107 and Figure 3-108.
- Step 2. Tighten M12 x 50 mm HHCS to secure rail support bracket to rail. **Tighten until bolts are snug + 1/4 turn.** Do not over tighten. Over tightening could cause bracket to bend.

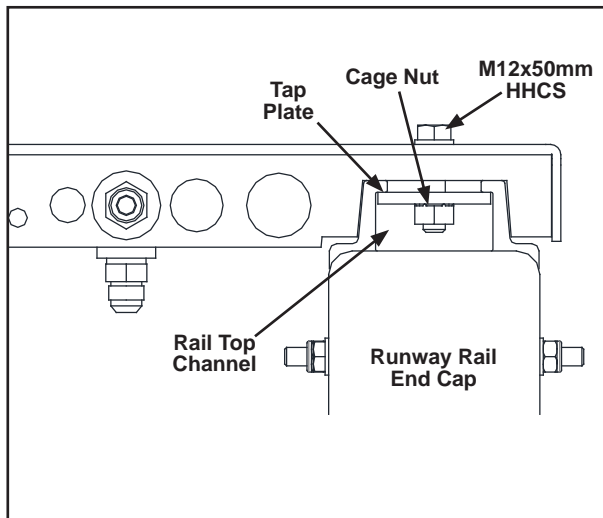

Figure 3-107

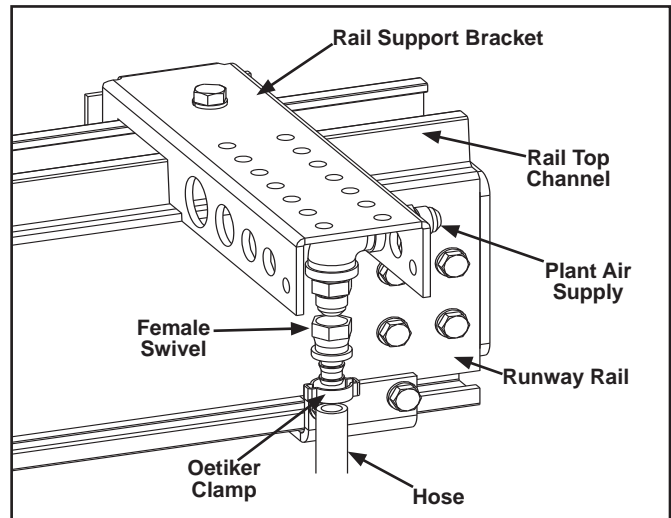

Figure 3-108

Continued on next page.

ACCESSORIES (CONTINUED)

Festooned Hose Management Kit (Continued)

If filter regulator was purchased continue with steps

Filter Regulator Installation

- a. Start at runway rail end closest to plant air supply. Loosen M12 HHCS and slide regulator bracket on to runway rail top channel. See Figure 3-109.
- b. Attach Leader hose from runway bracket assembly to regulator "out" port.
- c. Tighten M12 HHCS on regulator bracket assembly.
- d. Attach plant air supply to "in" port on filter regulator. Use at least one (12) in (305 mm) of hose between regulator and plant hard pipe.

CONTINUE WITH STEP 3.

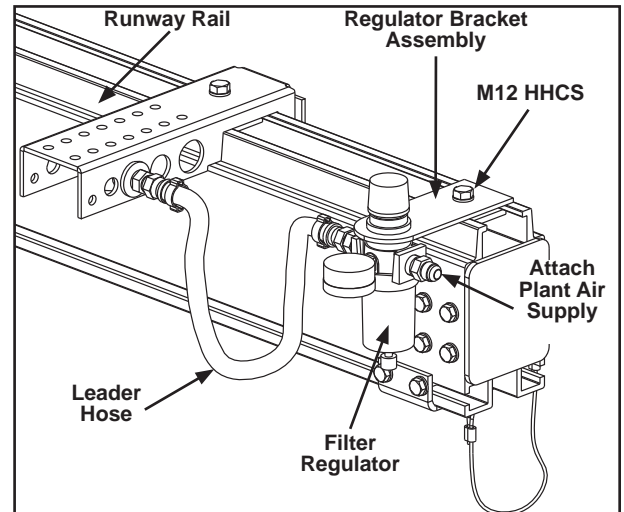



Figure 3-109

- Step 3. Remove runway rail end cap and roll hose trolley(s) into runway rail, alternating U-Bolts. Refer to this manual section "Hose Trolley" page 3-30.
- Step 4. Connect female swivel push on fitting with Oetiker clamp to hose end and attach to male part of assembly.
- Step 5. Remove U- bolts from festoon trolleys in order to attach hose.
- Step 6. Reinstall U-bolts trapping hose on trolley, alternating hose loops from inside to outside. Verify hose loops hang down from trolley with a length of approximately thirty-six (36) in (914 mm). Refer to this manual section "Hose Trolley" page 3-30.
- Step 7. Install runway rail end cap. Refer to this manual section "End Caps and Stops" page 3-20.

Transition Festoon Hose from Runway Rail to Bridge Rail

- Step 1. Loosen M10 x 50 mm HHCS on tap plate; slide transition bracket on to bridge rail bracket channel. Position bracket approximately six (6) inches (152 mm) from end truck. See Figure 3-110.
- Step 2. Tighten M10 x 50 mm HHCS to secure transition bracket to bridge. **Tighten until bolts are snug + 1/4 turn.** Do not over tighten. Over tightening could cause bracket to bend.
- Step 3. Install female swivel push on fitting with Oetiker clamp to hose end. Attach trailing end of runway rail hose into transition bracket assembly. See Figure 3-110.

	NOTE
Alternating hose loops will prevent hose pinching when bridge, fixture or hoist is rolled to air supply end of system. Hose should hang from trolley "U" bolts as if coiled on a spool.	

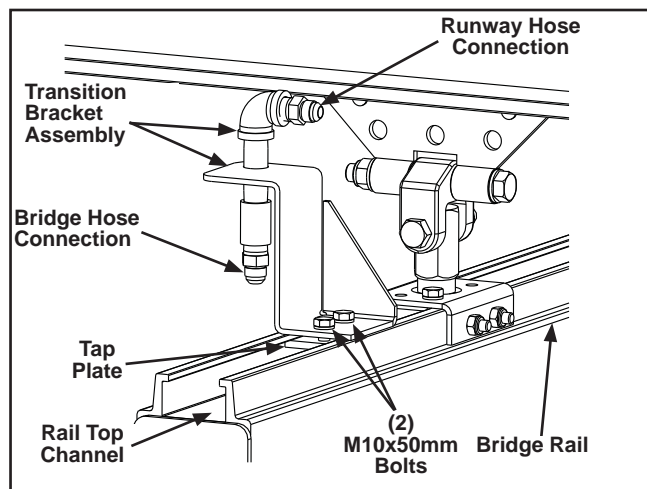

Figure 3-110

Continued on next page.

ACCESSORIES (CONTINUED)

Festooned Hose Management Kit (continued)

Festoon Hose Installation To Bridge

- Step 1. Attach rail support bracket by loosening cage nut and sliding rail support bracket into rail top channel. Position bracket approximately six (6) in (152 mm) from end of bridge rail. See Figure 3-111.
- Step 2. Tighten M12 x 50 mm HHCS to secure rail support bracket to rail. **Tighten until bolts are snug + ¼ turn.** Do not over tighten. Over tightening could cause bracket to bend.
- Step 3. Install leader hose between the runway and transition bracket.
- Step 4. Install female swivel push on fitting with Oetiker clamp to transition bracket end. Attach trailing end of leader hose to rail support bracket.
- Step 5. Remove rail end cap and roll hose trolley(s) into runway rail, alternating U-Bolts. Refer to this manual section "Hose Trolley" page 3-30.
- Step 6. Connect female swivel push on fitting with Oetiker clamp to hose end and attach to male part of assembly.
- Step 7. Remove U- bolts from festoon trolleys in order to attach hose.
- Step 8. Reinstall U-bolts trapping hose on trolley, alternating hose loops from inside to outside. Verify hose loops hang down from trolley with a length of approximately three (3) ft (914 mm). Refer to this manual section "Hose Trolley" page 3-30.
- Step 9. Insure all fittings are secure.
- Step 10. Install bridge rail end cap. Refer to this manual section "End Caps and Stops" page 3-20.
- Step 11. Attach leader plant air supply to rail support bracket 90 degree fitting (supplied). See Figure 3-112. Use at least twelve (12) in (305 mm) of hose between bracket and plant hard pipe. Do not hard pipe.
- Step 12. Install female swivel push on fittings with Oetiker clamp hose to end and attach male part of assembly.
- Step 13. Pressurize system and check for leaks.

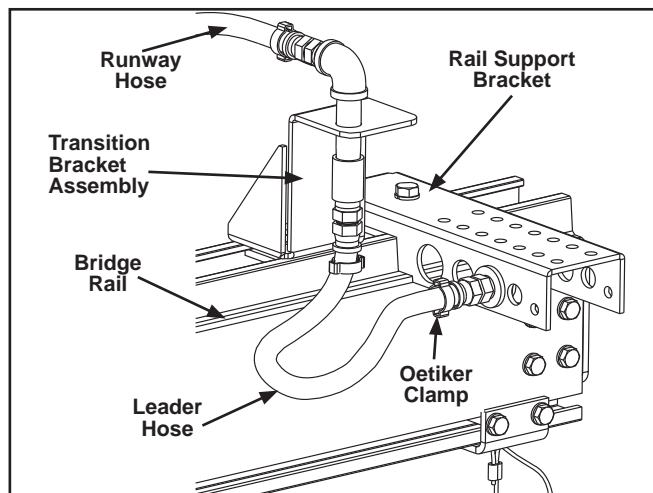

Figure 3-111

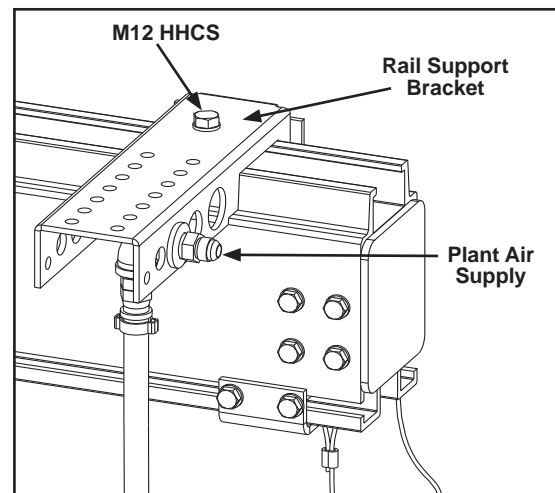

Figure 3-112

ACCESSORIES (CONTINUED)

Coiled Hose Management Kit

Part Number(s): MRMS4202

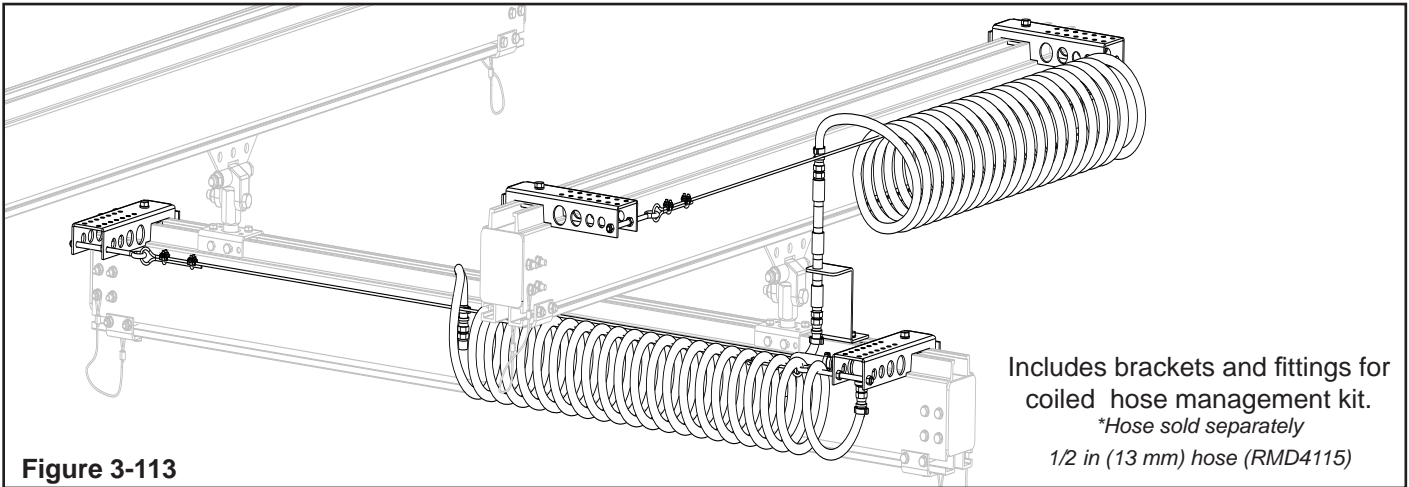



Figure 3-113

Includes brackets and fittings for coiled hose management kit.
 *Hose sold separately
 1/2 in (13 mm) hose (RMD4115)

⚠ WARNING



Use only fasteners provided by Knight Global. Do not use a system if end caps or stop assemblies are removed or damaged. All components must be installed according to instructions in this manual. All overhead attach points must have a safety cable installed according to manufacturer's instructions. Failure to comply may result in injury or death. Refer to page 2-3 for definition of "snug".

⚠ NOTE



All Knight products require clean, dry air only. Use thread sealant on all pipe threaded fittings, do not tape or "dope" 37° fittings.

⚠ NOTE



Coiled hose is not recommended with travel distances greater than twenty five (25) ft (7.62m)

INSTALLATION

Coiled Hose Installation To (Runway) Rail

- Step 1. Start at runway rail end closest to plant air supply. Attach rail support bracket (support bracket with fittings), loosen cage nut and slide support bracket on to rail top channel. Position approximately one (1) in (25 mm) from end of rail. See Figure 3-114 through Figure 3-116.
- Step 2. Tighten M12 x 50 mm HHCS to secure support bracket to top rail channel. **Tighten until bolts are snug + 1/4 turn.** Do not over tighten. Over tightening could cause bracket to bend.

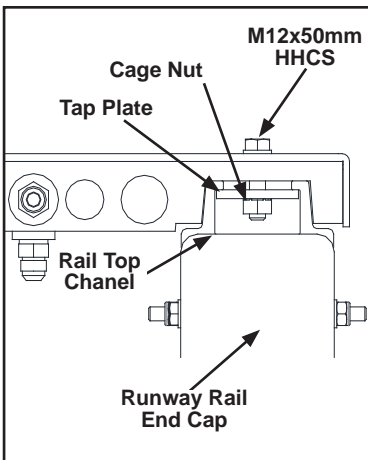

Figure 3-114

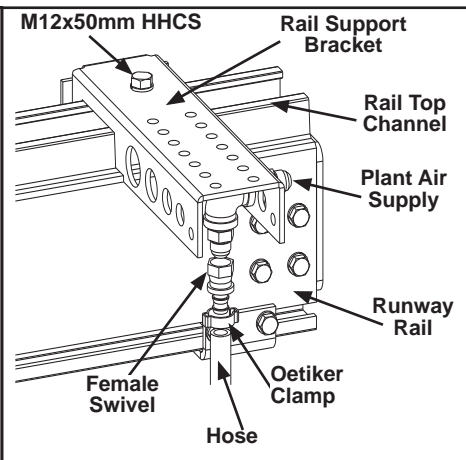

Figure 3-115

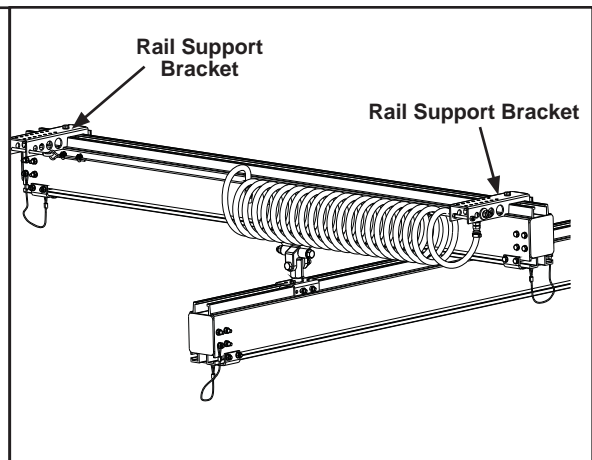

Figure 3-116

Continued on next page.

ACCESSORIES (CONTINUED)

Coiled Hose Management Kit (continued)

If filter regulator was purchased continue with steps

Filter Regulator Installation

- a. Start at runway rail end closest to plant air supply. Loosen M12 HHCS and slide regulator bracket on to runway rail top channel. See Figure 3-117.
- b. Attach Leader hose from runway bracket assembly to regulator "out" port.
- c. Tighten M12 HHCS on regulator bracket assembly.
- d. Attach plant air supply to "in" port on filter regulator. Use at least one (12) in (305 mm) of hose between regulator and plant hard pipe.

CONTINUE WITH STEP 3.

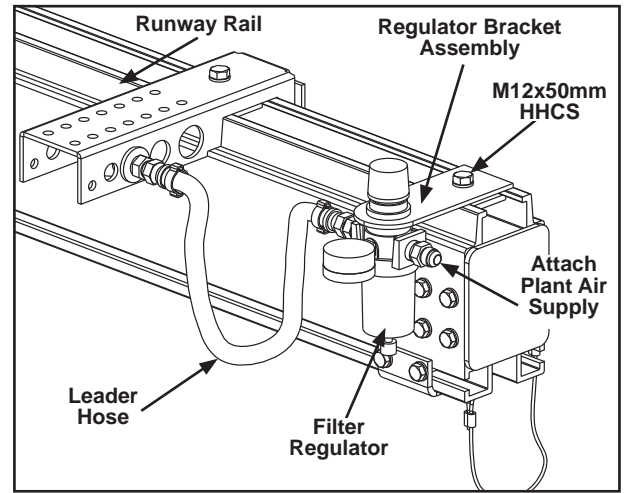

Figure 3-117

Attach (Runway) Rail Support Bracket To Opposite End Of (Runway) Rail

- Step 3. At opposite end of runway rail, attach rail support bracket assembly (bracket without fittings) by loosening cage nut on tap plate and sliding rail support bracket into rail top channel.
- Step 4. Tighten M12 x 50 mm HHCS to secure rail support bracket to rail. **Tighten until bolts are snug + ¼ turn.** Do not over tighten. Over tightening could cause bracket to bend. See Figure 3-118 and Figure 3-119.

Insert (Runway) Messenger Cable Through Coiled Hose

- Step 5. Determine length of messenger cable needed between rail support brackets.
- Step 6. Attach eye-bolt to rail support bracket assembly (bracket with fittings). See Figure 3-74.

	CAUTION
Plastic coating must be removed where Crosby® clamps contact messenger cable	

- Step 7. Loop end of messenger cable around eye-bolt. Attach Crosby® clamps over dead end of stripped messenger cable with cable resting in saddles. Tighten nuts on clamps, alternating sides.
- Step 8. Connect female swivel push on fitting with Oetiker clamp to hose end and attach to male part of assembly.
- Step 9. Thread eye-bolt and messenger cable through hose coils. Continue threading messenger cable through coils to other end of rail support bracket assembly. See Figure 3-118.
- Step 10. Attach eye-bolt to runway bracket assembly (bracket without fittings).
- Step 11. Loop end of messenger cable around eye-bolt. Attach Crosby® clamps over dead end of stripped messenger cable with cable resting in saddles. Tighten nuts on clamps, alternating sides.
- Step 12. Tighten eye-bolts until messenger cable is taut.

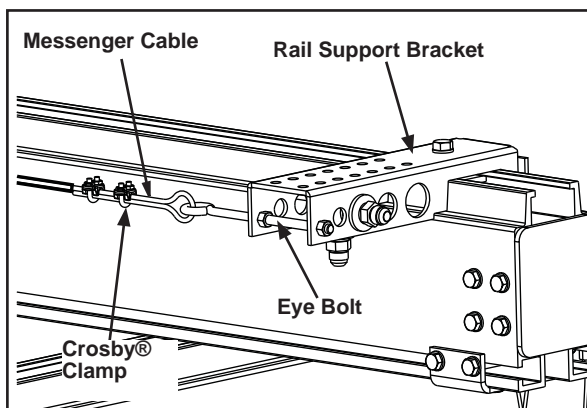

Figure 3-118

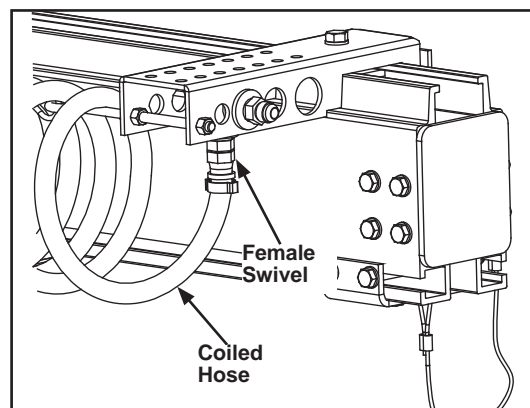

Figure 3-119

Continued on next page.

ACCESSORIES (CONTINUED)

Coiled Hose Management Kit (continued)

Transition Runway to Bridge

- Step 1. Attach transition bracket assembly to bridge rail. See Figure 3-120.
- Step 2. Loosen M10 HHCS x 50 mm on tap plate; slide transition bracket on to bridge top rail channel.
- Step 3. Tighten M10 bolts to secure transition bracket to bridge top rail channel. **Tighten until bolts are snug + ¼ turn.** Do not over tighten. Over tightening could cause bracket to bend. Attach trailing end of runway hose to transition bracket. See Figure 3-120.
- Step 4. Ensure runway hose coil is entering transition bracket from top.

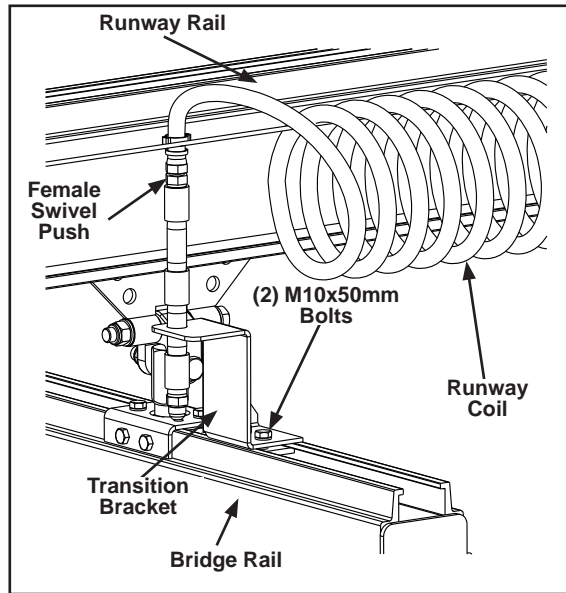

Figure 3-120

Coiled Hose Installation for (Bridge) Rail

- Step 1. Attach rail support bracket, loosen M12 HHCS and slide rail support bracket into bridge top channel.
- Step 2. Tighten M12 HHCS to secure support bracket to bridge top rail channel. See Figure 3-121.
- Step 3. Attach leader hose from transition bracket assembly. Install female swivel push on leader hose with Oetiker clamp to hose end and attach to male part of assembly.

Attach (Bridge) Rail Support Bracket to Opposite End

- Step 4. At opposite end of rail, attach rail support bracket by loosening M12 HHCS and sliding rail support bracket into bridge top channel. Tighten M12 HHCS to secure rail support bracket to rail. **Tighten until bolts are snug + ¼ turn.** Do not over tighten. Over tightening could cause bracket to bend. See Figure 3-122.

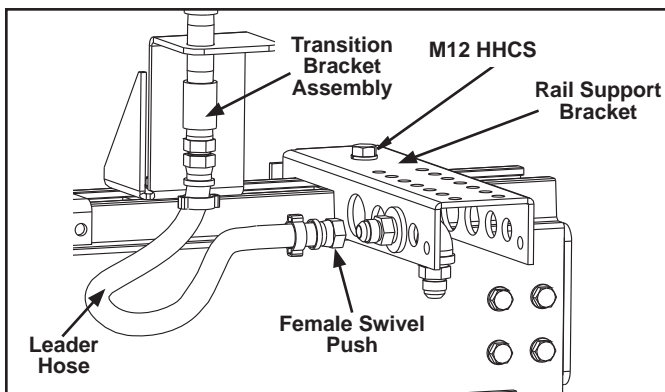

Figure 3-121

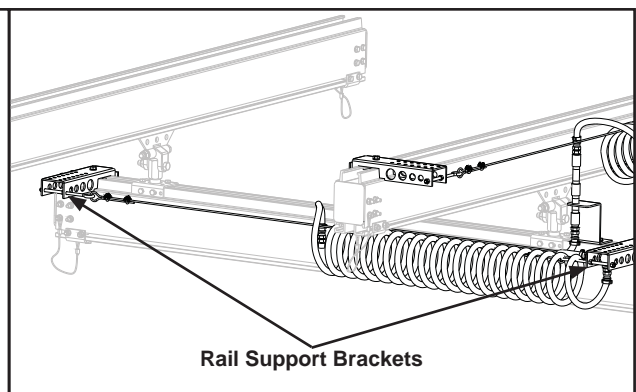

Figure 3-122

Continued on next page.

ACCESSORIES (CONTINUED)

Insert (Bridge) Messenger Cable Through Coiled Hose**CAUTION**

Plastic coating must be removed where Crosby® clamps contact messenger cable

- Step 5. Determine length of messenger cable needed between rail support brackets.
- Step 6. Attach eye-bolt to rail support bracket assembly (bracket with fittings). See Figure 3-123.
- Step 7. Loop end of messenger cable around eye-bolt. Attach Crosby® clamps over dead end of stripped cable with cable resting in saddles. Tighten nuts on clamps, alternating sides.
- Step 8. Connect female swivel push on fitting with Oetiker clamp to hose end and attach to male part of assembly.
- Step 9. Thread eye-bolt and messenger cable through hose coils. Continue threading messenger cable through coils to other end of rail support bracket assembly. See Figure 3-124.
- Step 10. Attach eye-bolt to bridge bracket assembly (bracket without fittings).
- Step 11. Loop end of messenger cable around eye-bolt. Attach Crosby® clamps over dead end of stripped cable with cable resting in saddles. Tighten nuts on clamps, alternating sides. See Figure 3-123
- Step 12. Tighten eye-bolts until messenger cable is taut.

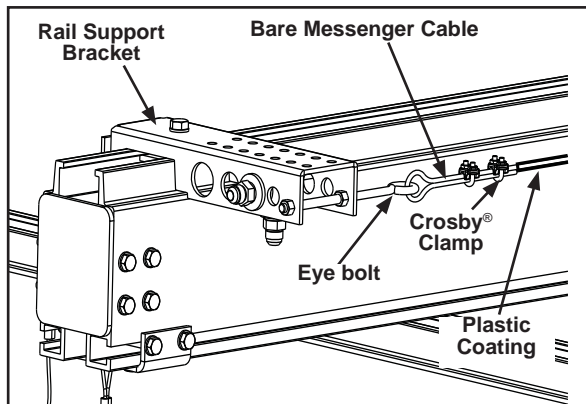

Figure 3-123

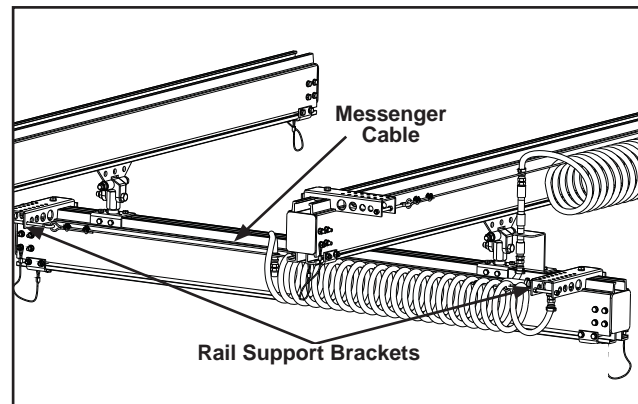

Figure 3-124

- Step 13. Attach leader plant air supply to rail support bracket at 90 degree fitting (supplied). See Figure 3-125. Use at least twelve (12) in (305 mm) of hose between bracket and plant hard pipe. Do not hard pipe. Install female swivel push on fittings with Oetiker clamp hose to end and attach male part of assembly.
- Step 14. Pressurize system and check for leaks.

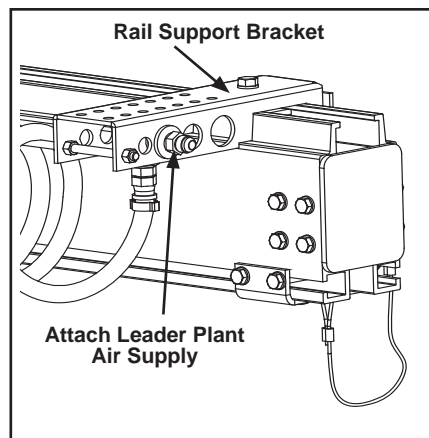



Figure 3-125

Add On Access Gate

Part Number(s): MRMA4975, MRMA7570

	WARNING
Use only fasteners provided by Knight Global. Do not use a system if end caps or stop assemblies are removed or damaged. All components must be installed according to instructions in this manual. All overhead attach points must have a safety cable installed according to manufacturer's instructions. Failure to comply may result in injury or death. Refer to page 2-3 for definition of "snug".	

	NOTE
Check layout for correct installation position. <i>A hanger must be installed above the add-on inspection gate.</i>	

Installation

- Step 1. Ensure side splice brackets and top rail mounting brackets are installed to Add On Access Gate.
- Step 2. Hoist access gate assembly into position between runway rails. Position rail and access gate together. See Figure 3-126 and Figure 3-127.
- Step 3. Center access gate between two rails to ensure they are square to each other and exhibit no gaps.
- Step 4. Slide one side splice bar into splice slot channel located on bottom of rail and access gate assembly, center over both end rail and access gate assembly.
- Step 5. Repeat process for second runway rail and access gate assembly.
- Step 6. Center top rail mounting bracket directly over splice created between rail and access gate assembly.
- Step 7. Repeat process with top rail mounting bracket, second runway rail and access gate.
- Step 8. Tighten eight (8) M10 x 30 mm HHCS on top rail mounting bracket to secure both rails to access gate. Tighten bolts until lock washer is flat. Do not over tighten.
- Step 9. Tighten sixteen (16) M8 x 30 mm HHCS on side splice bars. **Tighten until bolts are snug + ¼ turn.** Do not over tighten. Verify splice joint has no gaps.

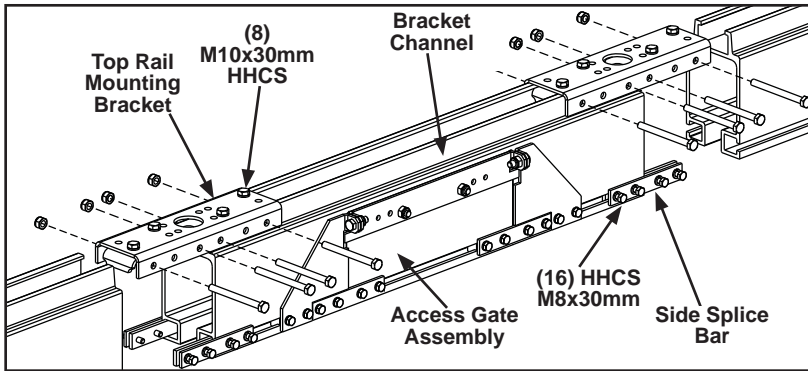

Figure 3-126

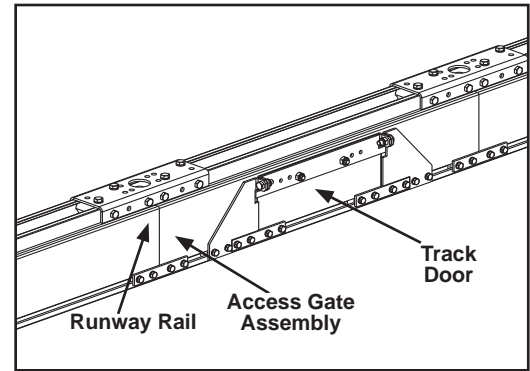

Figure 3-127

Cross Bolts

- Step 1. Use top rail mounting bracket as template to mark rail and drill four (4) holes on each end of access gate assembly, using 13/32 in (11 mm) drill bit. Do not attempt to drill holes in-line. See Figure 3-128.
- Step 2. Install four (4) M10 x 100 mm HHCS with M10 nylock nuts on each end of access gate. **Tighten until bolts are snug + ¼ turn.** Do not over tighten.

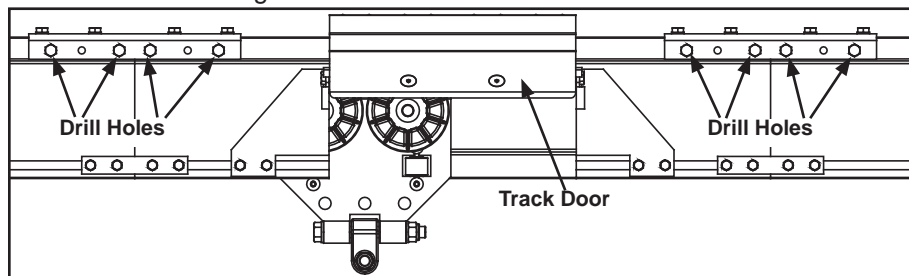

Figure 3-128

ACCESSORIES (CONTINUED)

Integrated Access Gate

Part Number(s): MRAA7560, MRAA6160, MRAA4965

**WARNING**

Use only fasteners provided by Knight Global. Do not use a system if end caps or stop assemblies are removed or damaged. All components must be installed according to instructions in this manual. All overhead attach points must have a safety cable installed according to manufacturer's instructions. Failure to comply may result in injury or death. Refer to page 2-3 for definition of "snug".

**NOTE**

Check layout for correct installation position. If there is no layout, ensure gate is positioned where access to the trolley is easily accessible. A hanger must be installed within 12" (305mm) of the inspection gate.

Installation

- Step 1. Loosen four (4) M8 x 30 mm HHCS on each of the two (2) splice bars.
- Step 2. Slide splice bars towards middle of track door.
- Step 3. Lift track door open for access to inside rail and inspection of trolley(ies).
- Step 4. Close gate and slide splice bars over track door and bottom of rail.
- Step 5. Tighten eight (8) M8 x 30 mm HHCS on side splice bars. Tighten bolts until lock washer is flat. Do not over tighten.

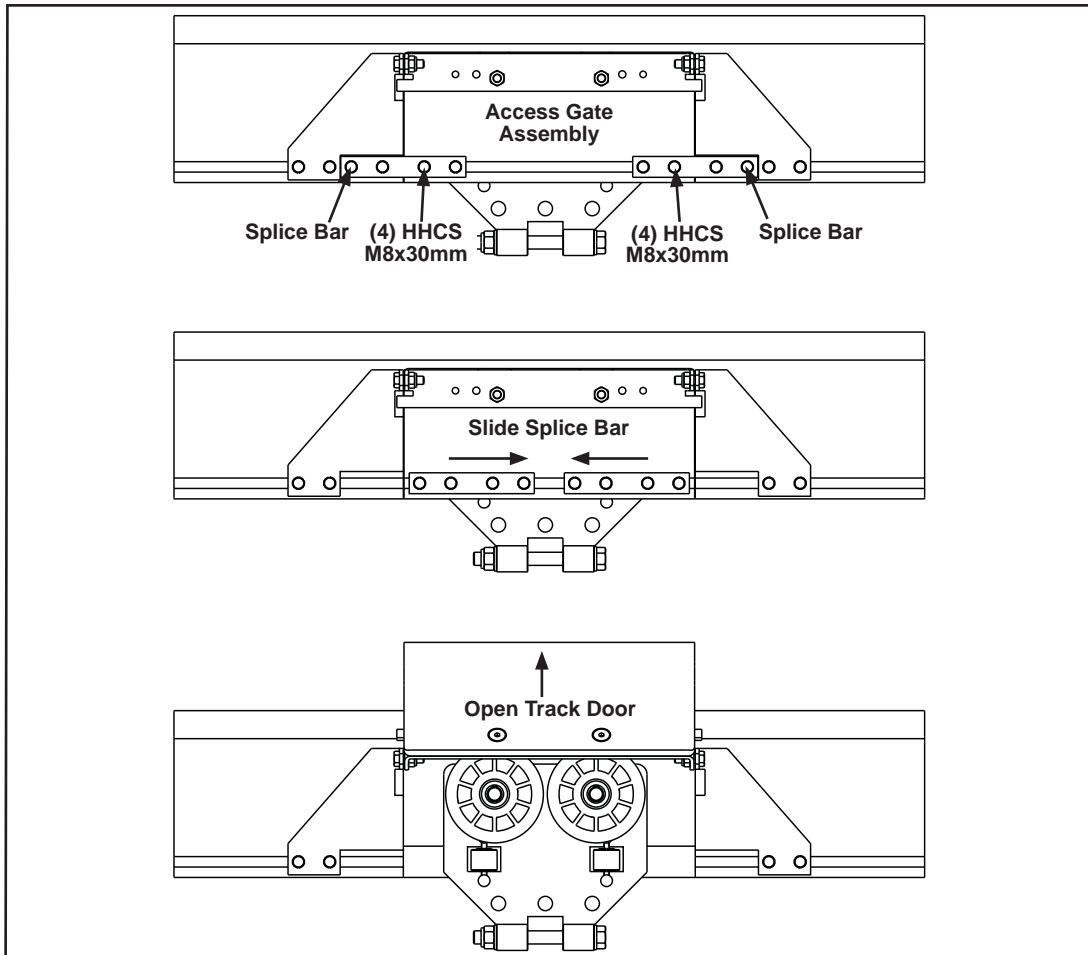
**Figure 3-129**

ACCESSORIES (CONTINUED)

Zone Ramp with Limit Switch

Part Number(s): MRAA7170-12, MRAA7170-24, MRAA7170-36, MRAA7170-48

**WARNING**

Use only fasteners provided by Knight Global. Do not use a system if end caps or stop assemblies are removed or damaged. All components must be installed according to instructions in this manual. All overhead attach points must have a safety cable installed according to manufacturer's instructions. Failure to comply may result in injury or death. Refer to page 2-3 for definition of "snug".

Installation

- Step 1. Loosen four (4) M8 x 30mm HHCS mounting bracket bolts and slide ramp tap plates and mounting bracket on side of tool channel. Position per system layout. Do not tighten ramp to rail, adjustments will be made in later steps. See Figure 3-130 and 3-131 .
- Step 2. Secure limit switch assembly bracket to trolley by inserting two (2) M16x40mm HHCS through trolley bolt hole pattern and limit switch bolt hole pattern. **Tighten until bolts are snug + ¼ turn.** Do not over tighten. Over tightening could cause bracket to bend. See Figure 3-132.
- Step 3. Align roller lever and ramp to ensure lever is activated when making contact with ramp. If necessary, adjust ramp vertically by loosening the four (4) M8x30mm HHCS bolts and move the adjustment plate either up or down. Adjust the ramp horizontally by loosening the two (2) M8x20mm HHCS bolts and move the ramp inwards or outwards until limit roller is making contact. See Figures 3-133.
- Step 4. Roll trolley back and forth to ensure limit roller lever is properly hitting the ramp.
- Step 5. Tighten the four (4) M8x30mm HHCS bolts and (2) M8x20mm HHCS bolts loosened in Step 3. **Tighten until bolts are snug + ¼ turn.** Do not over tighten.

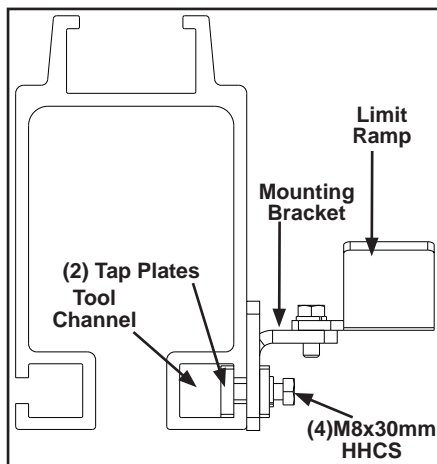

Figure 3-130

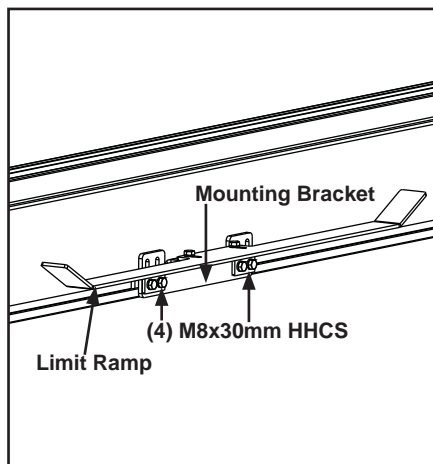

Figure 3-131

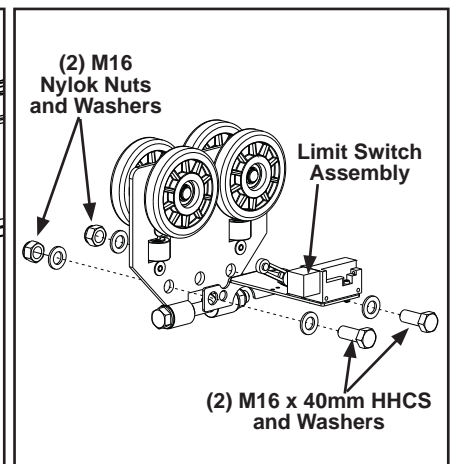

Figure 3-132

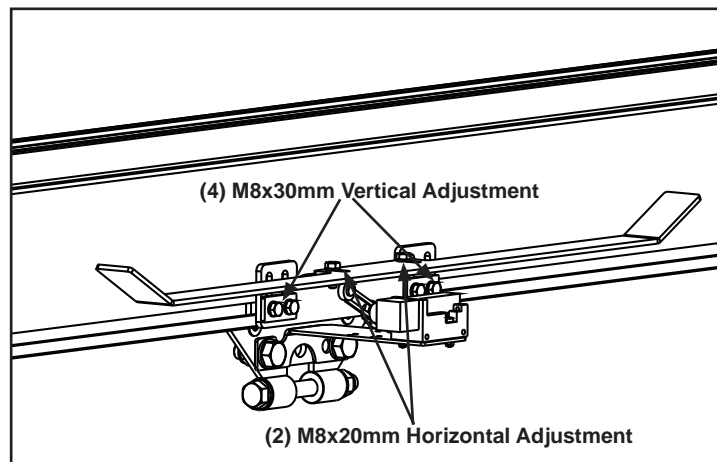

Figure 3-133

ACCESSORIES (CONTINUED)

End of Travel Limit Switch

Part Number(s): MRAA4228



WARNING

Use only fasteners provided by Knight Global. Do not use a system if end caps or stop assemblies are removed or damaged. All components must be installed according to instructions in this manual. All overhead attach points must have a safety cable installed according to manufacturer's instructions. Failure to comply may result in injury or death. Refer to page 2-3 for definition of "snug".

Installation

- Step 1. Remove cross bolts. Loosen M12 x 45mm HHCS mounting bracket bolt and slide rail mounting bracket on top of bracket channel and tap plate into bracket channel at top of runway rail. Position per system layout. See Figure 3-134.
- Step 2. Align roller lever onto limit switch pin. Do not tighten lever onto pin, adjustments will be made in later steps. See Figure 3-135.
- Step 3. Secure tripper flag bracket to trolley by inserting two (2) M16x40mm HHCS through trolley bolt hole pattern and tripper flag bolt hole pattern. **Tighten until bolts are snug + 1/4 turn.** Do not over tighten. Over tightening could cause bracket to bend. See Figure 3-136.
- Step 4. Align roller lever and tripper flag to ensure lever is activated when making contact with tripper flag. Adjust limit switch by loosening the four (4) M6x20mm SHCS bolts and move the adjustment plate either up or down. A minimum of 1/4 in. (6.3mm) between the bottom of the limit switch and tripper flag. Tighten the four (4) M6x20mm SHCS bolts. Tighten roller lever bolt on limit switch pin. See Figures 3-137 and 3-138.
- Step 5. Roll trolley back and forth to ensure limit roller lever is properly hitting the tripper flag.
- Step 6. Tighten M12x45mm HHCS mounting bracket bolt until lock washer is flat. Do not over tighten.

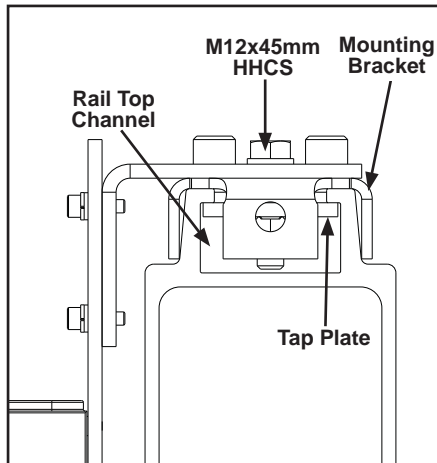

Figure 3-134

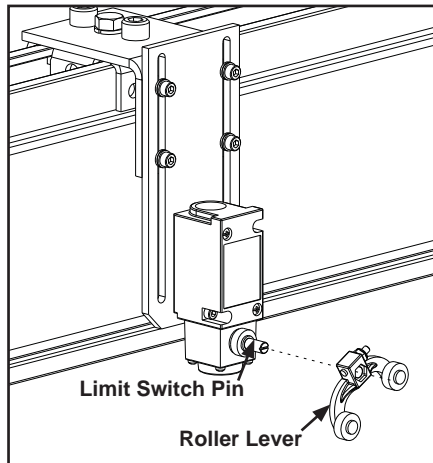

Figure 3-135

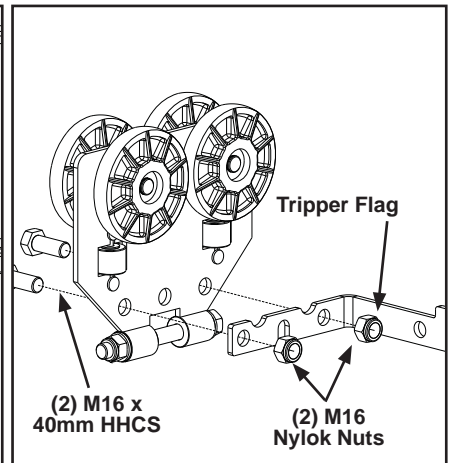

Figure 3-136

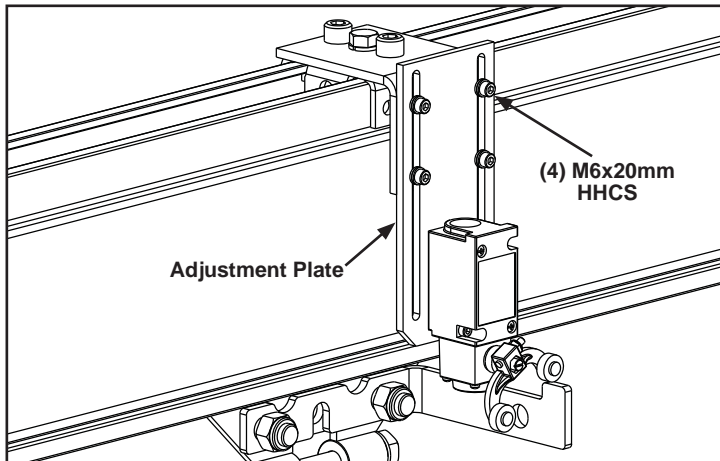

Figure 3-137

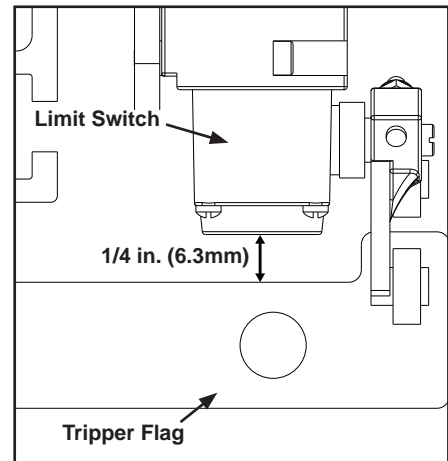

Figure 3-138

Side by Side Hanger

Part Number(s): TRH2020



WARNING

Use only fasteners provided by Knight Global. Do not use a system if end caps or stop assemblies are removed or damaged. All components must be installed according to instructions in this manual. All overhead attach points must have a safety cable installed according to manufacturer's instructions. Failure to comply may result in injury or death. Refer to page 2-3 for definition of "snug".

Installation

- Step 1. Remove the M10 x 100mm HHCS and M10 Nylok from the U-bracket on all TRH2020 hanger assemblies. See Figure 3-139
- Step 2. Remove end cap(s) on TR2000 side rail.
- Step 3. Loosen (2) M8 x 20mm HHCS mounting U-bracket bolts and slide rail mounting bracket on top of bracket channel and tap plate into bracket channel at top of TR2000 side rail. Repeat for each hanger as needed. Position hangers on side TR2000 rail per system layout. Leave U-brackets loose to allow for adjustments if needed later in the installation process. See Figure 3-140.
- Step 4. Remove the M12 x 50mm mounting bracket bolt and lock washer from the top mounting bracket on the primary rail. Place the tap plate, flat side facing up and welded nut face down, inside the top bracket channel of the primary rail per system layout. See Figure 3-141.
- Step 5. Align top bracket of TRH2020 over the tap plate in the top bracket channel. Insert M12 x 50mm and flat washer through top bracket and into the tap plate. Lift tap plate until threads of the bolt enter the nut welded to tap plate and hand tighten bolt until snug. Repeat for each top bracket of TRH2020 as needed. See Figure 3-141

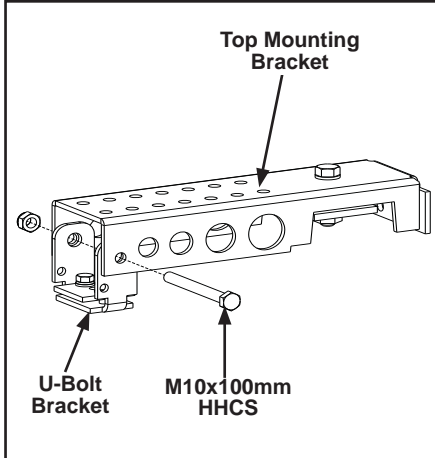

Figure 3-139

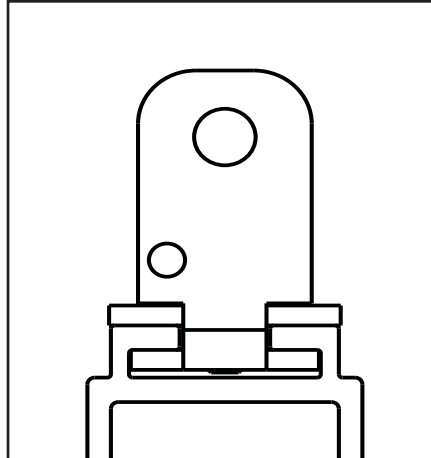

Figure 3-140

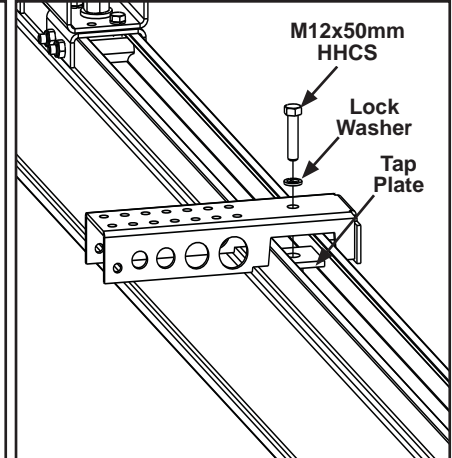

Figure 3-141

- Step 6. Lift the TR2000 side rail up to the primary rail and align the U-brackets with the top brackets of the TRH2020. Insert the M10 x 100mm HHCS and M10 Nylok removed in step 1 through the top bracket and U-bracket. **Tighten until bolts are snug + ¼ turn.** Do not over tighten. Over tightening could cause bracket to bend. Repeat for each bracket of TRH2020 as needed. See Figure 3-139.
- Step 7. Tighten M12x50mm HHCS mounting bracket bolts from step 5 until lock washers are flat. Do not over tighten.
- Step 8. Tighten M8 x 20mm HHCS mounting U-bracket bolts from step 3. **Tighten until bolts are snug + ¼ turn.** Do not over tighten. Over tightening could cause bracket to bend.
- Step 9. Install end cap(s) on TR2000 side rail.

Bridge Bumper

Part Number(s): MRAA4926



WARNING

Use only fasteners provided by Knight Global. Do not use a system if end caps or stop assemblies are removed or damaged. All components must be installed according to instructions in this manual. All overhead attach points must have a safety cable installed according to manufacturer's instructions. Failure to comply may result in injury or death. Refer to page 2-3 for definition of "snug".

Installation

- Step 1. Remove the two (2) M16 x 50mm HHCS, M16 Nylocks, and washers from the bridge bumper bracket assembly.
- Step 2. Align bolt hole pattern on bridge bumper with end truck bolt hole pattern as shown below. See Figure 3-142.
- Step 3. Insert the two (2) M16 x 50mm HHCS, M16 Nylocks, and washers removed in step 1 through the bridge bumper bracket assembly and end truck. **Tighten until bolts are snug + ¼ turn.** Do not over tighten. Over tightening could cause bracket to bend. See Figure 3-142.
- Step 4. Repeat steps 1-3 for each bridge bumper required. Refer to station layout drawings if provided. See Figure 3-144 to show two (2) bridge bumpers installed.

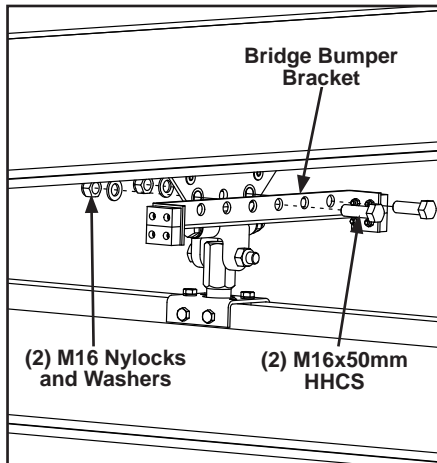

Figure 3-142

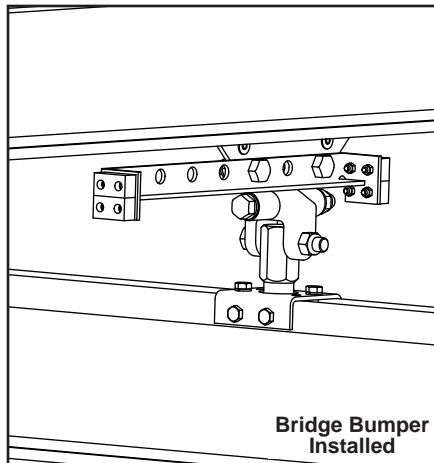

Figure 3-143

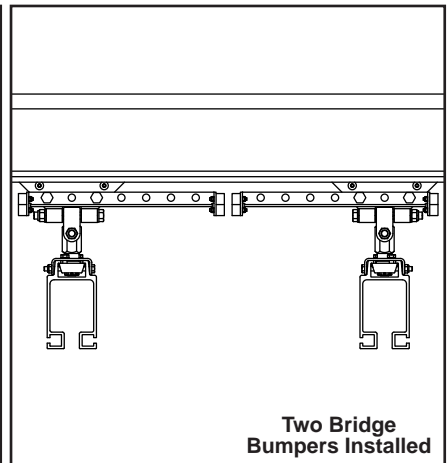

Figure 3-144

ACCESSORIES (CONTINUED)

Safety Cabling

Part Number(s): RWA4133

Parts List

- (1) Safety Cable (1/4" galvanized cable), (4) Crosby® Clips, (2) Cable Thimbles.

See Figure 3-145 to follow the Crosby Clip installation specifications below or download at <https://www.thecrosbygroup.com/wp-content/uploads/2013/12/56.pdf> to print a copy.

Figure 3-145

CROSBY® CLIPS
WARNINGS AND APPLICATION
INSTRUCTIONS



⚠ WARNING

- Failure to read, understand, and follow these instructions may cause death or serious injury.
- Read and understand these instructions before using clips.
- Match the same size clip to the same size wire rope.
- Prepare wire rope end termination only as instructed.
- Do not use with plastic coated wire rope.
- Apply first load to test the assembly. This load should be of equal or greater weight than loads expected in use. Next, check and retighten nuts to recommended torque (See Table 1).

Efficiency ratings for wire rope end terminations are based upon the minimum breaking force of wire rope. The efficiency rating of a properly prepared loop or thimble-eye termination for clip sizes 1/8" through 7/8" is 80%, and for sizes 1" through 3-1/2" is 90%.

The number of clips shown (see Table 1) is based upon using RRL or RLL wire rope, 6 x 19 or 6 x 36 Class, FC or IWRC; IPS or XIP, XXIP. If Seale construction or similar large outer wire type construction in the 6 x 19 Class is to be used for sizes 1 inch and larger, add one additional clip. If a pulley (sheave) is used for turning back the wire rope, add one additional clip.

The number of clips shown also applies to rotation-resistant RRL wire rope, 8 x 19 Class, IPS, XIP, XXIP sizes 1-1/2 inch and smaller; and to rotation-resistant RRL wire rope, 19 x 7 Class, IPS, XIP, XXIP sizes 1-3/4 inch and smaller.

For other classes of wire rope not mentioned above, we recommend contacting Crosby Engineering to ensure the desired efficiency rating.

For elevator, personnel hoist, and scaffold applications, refer to ANSI A17.1 and ANSI A10.4. These standards do not recommend U-Bolt style wire rope clip terminations. The style wire rope termination used for any application is the obligation of the user.

For OSHA (Construction) applications, see OSHA 1926.251.

1. Refer to Table 1 in following these instructions. Turn back specified amount of rope from thimble or loop.



Figure 1

Apply first clip one base width from dead end of rope. Apply U-Bolt over dead end of wire rope – live end rests in saddle (Never saddle a dead horse!). Use torque wrench to tighten nuts evenly, alternate from one nut to the other until reaching the recommended torque. (See Figure 1)

2. When two clips are required, apply the second clip as near the loop or thimble as possible. Use torque wrench to tighten nuts evenly, alternating until reaching the recommended torque.



Figure 2

When more than two clips are required, apply the second clip as near the loop or thimble as possible, turn nuts on second clip firmly, but do not tighten. (See Figure 2)

3. When three or more clips are required, space additional clips equally between first two – take up rope slack – use torque wrench to tighten nuts on each U-Bolt evenly, alternating from one nut to the other until reaching recommended torque. (See Figure 3)



Figure 3

4. If a pulley (sheave) is used in place of a thimble, add one additional clip. Clip spacing should be as shown. (See Figure 4)

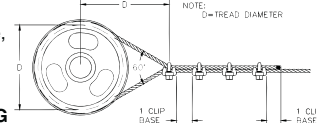

Figure 4

5. WIRE ROPE SPLICING PROCEDURES:

The preferred method of splicing two wire ropes together is to use inter-locking turnback eyes with thimbles using the recommended number of clips on each eye (See Figure 5).

An alternate method is to use twice the number of clips as used for a turnback termination. The rope ends are placed parallel to each other, overlapping by twice the turnback amount shown in the application instructions. The minimum number of clips should be installed on each dead end (See Figure 6). Spacing, installation torque, and other instructions still apply.

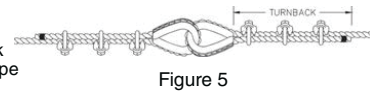

Figure 5

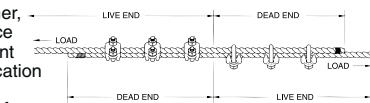

Figure 6

6. IMPORTANT

Apply first load to test the assembly. This load should be of equal or greater weight than loads expected in use. Next, check and use torque wrench to retighten nuts to recommended torque. In accordance with good rigging and maintenance practices, the wire rope end termination should be inspected periodically for wear, abuse, and general adequacy.

Table 1

Clip Size (in.)	Rope Size (in.)	Minimum No. of Clips	Amount of Rope to Turn Back in Inches	* Torque in Ft.Lbs.
1/8	1/8	2	3-1/4	4.5
3/16	3/16	2	3-3/4	7.5
1/4	1/4	2	4-3/4	15
5/16	5/16	2	5-1/4	30
3/8	3/8	2	6-1/2	45
7/16	7/16	2	7	65
1/2	1/2	3	11-1/2	65
9/16	9/16	3	12	95
5/8	5/8	3	12	95
3/4	3/4	4	18	130
7/8	7/8	4	19	225
1	1	5	26	225
1-1/8	1-1/8	6	34	225
1-1/4	1-1/4	7	44	360
1-3/8	1-3/8	7	44	360
1-1/2	1-1/2	8	54	360
1-5/8	1-5/8	8	58	430
1-3/4	1-3/4	8	61	590
2	2	8	71	750
2-1/4	2-1/4	8	73	750
2-1/2	2-1/2	9	84	750
2-3/4	2-3/4	10	100	750
3	3	10	106	1200
3-1/2	3-1/2	12	149	1200

If a pulley (sheave) is used for turning back the wire rope, add one additional clip. See Figure 4.

If a greater number of clips are used than shown in the table, the amount of turnback should be increased proportionately.

*The tightening torque values shown are based upon the threads being clean, dry, and free of lubrication.

ACCESSORIES (CONTINUED)

Safety Cabling Components Installation**Hangers** (See Figure 3-146)

- Step 1. Route safety cable underneath hanger tap plate located in top bracket channel of rail.
- Step 2. Continue to route safety cable over structural beam.
- Step 3. Do not overlap cable ends. Use interlocking eye method with thimbles shown on page 3-45.

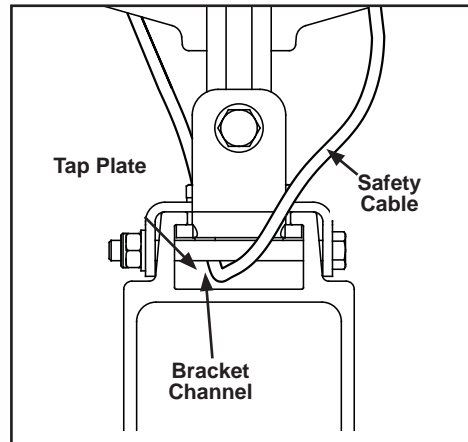
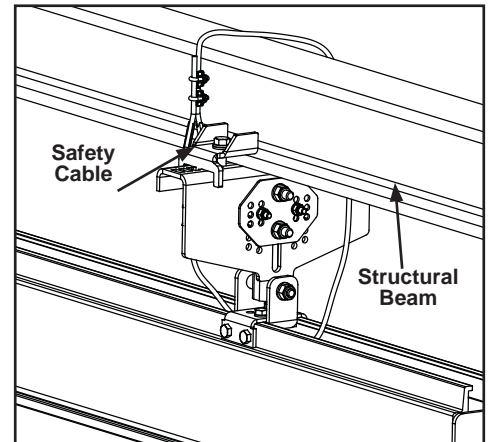

Figure 3-146

**Trolleys** (See Figure 3-147)

Any accessory attached to trolley must be safety cabled to trolley.

Trolleys attached to carriage frame must be safety cabled.

- Step 1. Insert safety cable through center hole of trolley.
- Step 2. Feed safety cable through carriage frame or fixture.

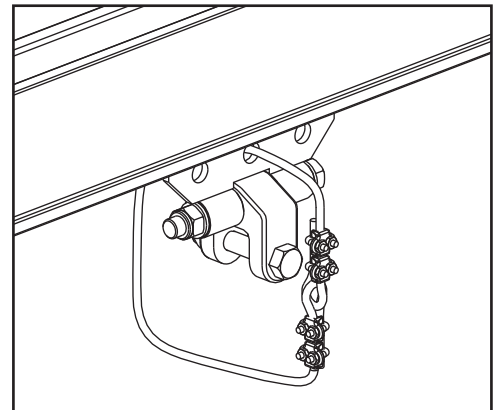

Figure 3-147

End Trucks (See Figure 3-148)

- Step 1. Verify End truck is pre-cabled. End trucks should have safety cable pass under rail bracket.
- Step 2. Insert safety cable through center hole of end truck.
- Step 3. Feed safety cable under hanger tap plate located underneath top channel lip.

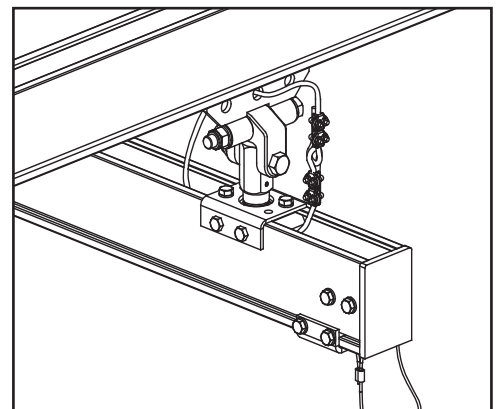

Figure 3-148

ACCESSORIES (CONTINUED)

Safety Cabling Components Installation

Rigid End Trucks (See Figure 3-149)

- Step 1. Insert safety cables (A) through bottom center hole of each trolley and feed through end hole of cross bracket.
- Step 2. Use top rail mounting bracket as template to mark rail and drill four (4) holes on each end of mounting bracket, using 13/32 in (11 mm) drill bit. Do not attempt to drill holes in-line.
- Step 3. Feed safety cables (B) through holes drilled in rail. Insert cable through mounting bracket.

Note: If end trucks are cross-bolted to rail, safety cables (B) are optional based upon plant specific safety regulations.

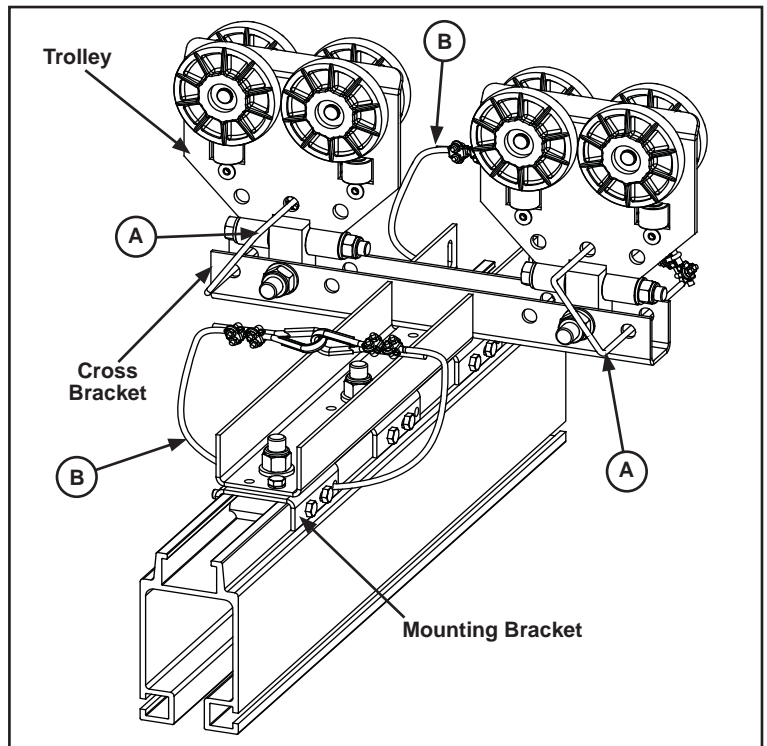

Figure 3-149

Same Plane End Trucks (See Figure 3-150)

- Step 1. Insert safety cable through bottom center hole of each trolley and feed through hole of back plate on same plane assembly.
- Step 2. Use top rail mounting bracket as template to mark rail and drill four (4) holes on each end of outer mounting bracket, using 13/32 in (11 mm) drill bit. Do not attempt to drill holes in-line.
- Step 3. Feed safety cables through holes drilled in rail. Insert cable through outer mounting bracket.

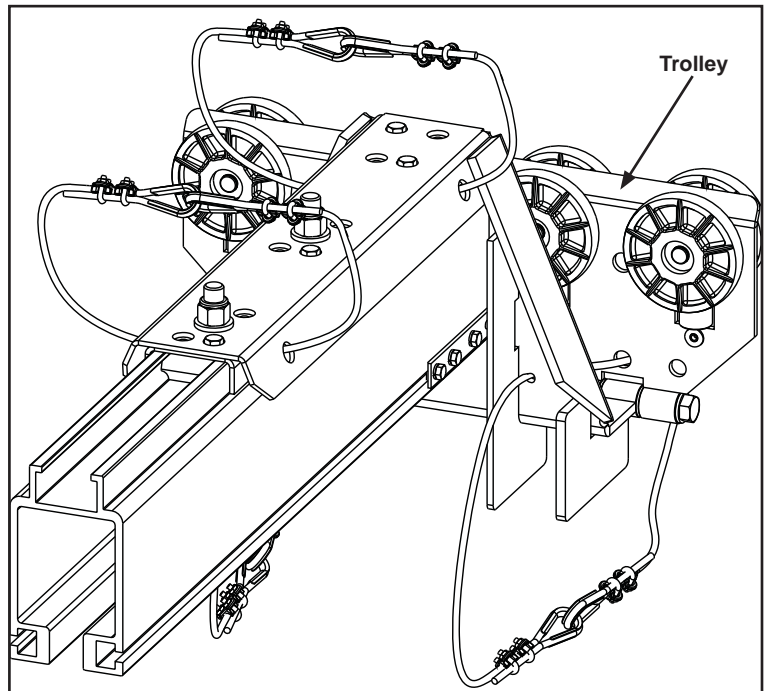

Figure 3-150

Optional Safety Cabling - Nicopress and Sleeves

Part Number(s): NICORWA4133

The required method of splicing two (2) wire ropes together is to use inter-locking turn-back eyes with thimbles, using recommended number of sleeves on each eye. See Figure 3-151.

Parts List

- (1) Safety Cable (1/4" galvanized aircraft cable Federal spec. #RR-W-410D, meeting military spec. #MIL-W-83420D for dimensional tolerance and strength)
- (2) Cable Thimbles (for loads exceeding 200 lbs. [91 kg.]
- (2) 1/4" copper oval Nicopress Sleeves
- (1) Nicopress sleeve gauge

	NOTE
Do not overlap cable ends. Use eye method with thimbles. See Figure 3-151.	

Safety Cabling Installation

- Step 1. Slide thimbles together. See Figure 3-151.
- Step 2. Turn back a minimum of 2.5" (63.5 mm) of the 1/4" cable rope on the thimble or loop as shown in Figure 3-151 below.
- Step 3. Assemble components together leaving a minimum of 1.00" (25.4 mm) of the 1/4" cable rope "dead-end" protruding out of the Nicopress sleeves as shown in Figure 3-151.
- Step 4. Using a hand or powered swagger press, press the Nicopress sleeve (3) times.
- Step 5. Using a sleeve press gage, check Nicopress sleeve clearances using the 1/4" Oval Sleeve slot and check for proper press. Sleeve gage should slide over swagger without applying any force.

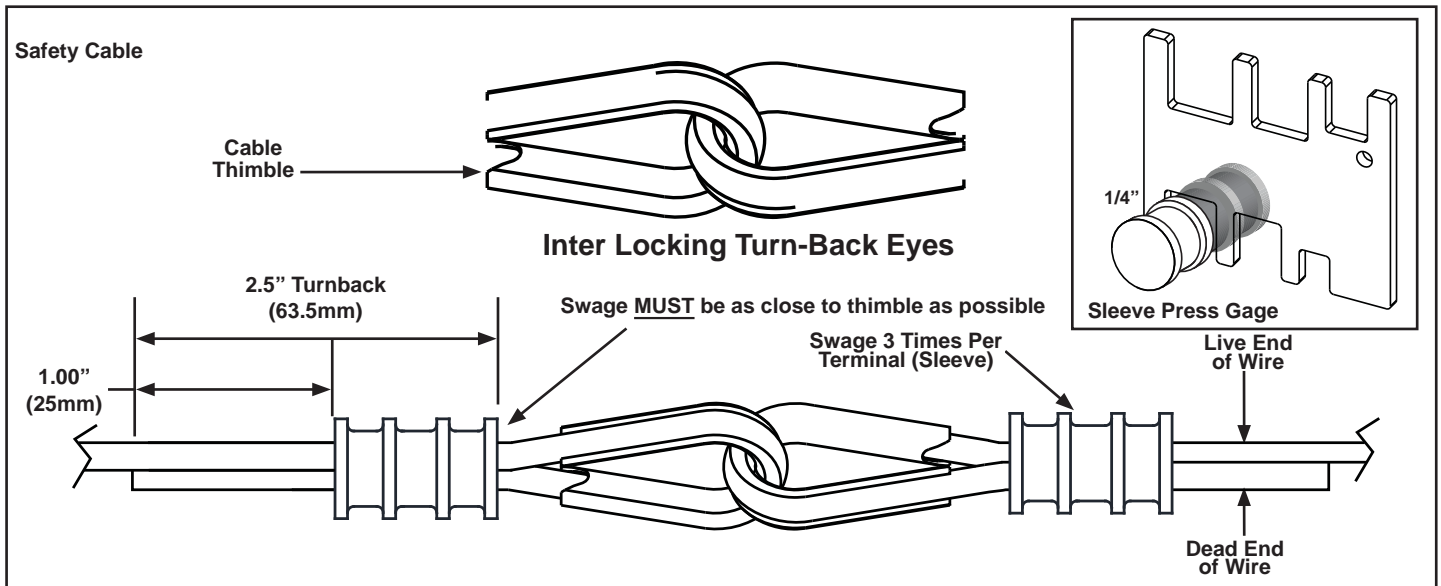

Figure 3-151

Continued on next page.

ACCESSORIES (CONTINUED)

Nicopress Safety Cabling Components Installation

NICOPRESS HAND TOOLS FOR NICOPRESS OVAL AND STOP SLEEVES

# 17-BA	# 51-B4-887	# 51-F2-850	# 3-C-887	# 3-G9-950
# 17-B4B	# 51-C-887	# 51-Q-929	# 3-G-887	# 3-H5-950
# 31-B	# 51-G-887	# 51-MJ	# 3-M-850	# 3-Q-929
# 31-B4	# 51-M-850	# 63V-XPM	# 3-P-850	# 3-MJ
# 32-VC:VG	# 51-P-850	# 64-CGMP	# 3-X-850	# 3V-CGMP
# 33V-CGB4	# 51-X-850	# 63V-XPM/Cutter	# 3-F2-850	# 3V-F6:X:M
	# 51-Y-850	# 64-CGMP/Cutter	# 3-F2-950	# 3V-XPM
			# 3-F6-950	

NICOPRESS BENCH TOOL HEADS

The heads used in bench tools are the same as the "heads only" of corresponding *Nicopress hand tools as follows:*

No. 510 Bench Tool Heads

# 51-B4-887 Head	# 51-X-850 Head	# 63V-XPM Head
# 51-C-887 Head	# 51-Q-929 Head	# 64-CGMP Head
# 51-G-887 Head	# 51-Y-850 Head	
# 51-M-850 Head	# 51-F2-850 Head	
# 51-P-850 Head	# 51-MJ Head	

No. 510 Bench Tool Heads are completely interchangeable with each other

No. 300 Bench Tool Heads

# 3-C-887 Head	# 3-F2-850 Head	# 3-Q-929 Head
# 3-G-887 Head	# 3-F2-950 Head	# 3-MJ Head
# 3-M-850 Head	# 3-F6-950 Head	# 3V-CGMP Head
# 3-P-850 Head	# 3-G9-950 Head	# 3V-F6:X:M Head
# 3-X-850 Head	# 3-H5-950 Head	# 3V-XPM Head

No. 300 Bench Tool Heads are completely interchangeable with each other

MAKING SPLICES WITH NICOPRESS OVAL SLEEVES

To make EYE SPLICES, pull enough cable through the sleeve so that the end will still protrude after swaging. Line up the sleeve between the tool jaws as shown with the long axis crosswise to the jaws.

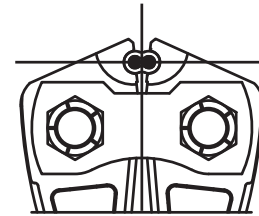
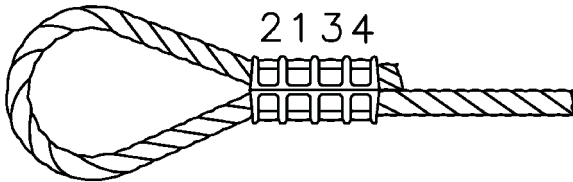

Using the proper Nicopress tool, swage the sleeve with the correct number of presses, spacing the presses evenly on the sleeve. If more than 1 compression is required per sleeve, use the pressing sequence shown above. Tables which follow list the number of presses required for each sleeve. Space crimps apart as shown, except where overlapped presses are specified. Overlapped presses are specified for sleeves that need more than one press, but do not have room for two complete presses. Overlapped presses should compress all of the sleeve. To properly install, it is important the sleeve be fully and correctly pressed. To check this, use the gauge furnished with the tool on a completed sleeve press. Sleeves should enter slot freely. Adjust tool if sleeve does not enter gauge. (See Page 4 for information on using the gauge and adjusting tools.)

For maximum holding strength: Use Nicopress Plain Copper Oval Sleeves or Zinc Plated Copper Oval Sleeves on Galvanized Steel Aircraft Cable. Use Nicopress Tin Plated Copper Oval Sleeves or Stainless Steel Oval Sleeves on Stainless Steel Aircraft Cable.

LAP SPLICES can also be made with Nicopress Oval Sleeves. Usually 2 sleeves are needed to develop full strength. A short space should be kept between the sleeves as shown. The cable ends should protrude after swaging.



Continued on next page.

ACCESSORIES (CONTINUED)

Nicopress Safety Cabling Components Installation

HAND TOOLS AND NO. 300 BENCH TOOL HEADS FOR OVAL SLEEVES					
CABLE SIZE	SLEEVE NUMBER	HAND TOOL NUMBER	300 BENCH TOOL HEAD NUMBER	TOOL GROOVE	PRESSES REQUIRED
3/64	168-1.5-VB4	3-B4-887	3-B4-887 HEAD	OVAL B4	1
1/16	168-2-VB4	3-B4-887	3-B4-887 HEAD	OVAL B4	1
	18-1-C; 28-1-C; 188-2-VC; 428-2-VC	3-C-887; 3V-CGMP	3-C-887 HEAD; 3V-CGMP HEAD	OVAL C	1
3/32	168-3-VC	3-C-887	3-C-887 HEAD	OVAL C	1
	18-2-G; 28-2-G; 428-3-VG	3-G-887; 3V-CGMP	3-G-887 HEAD; 3V-CGMP HEAD	OVAL G	1
	188-3-VG	3-G-887; 3V-CGMP	3-G-887 HEAD; 3V-CGMP HEAD	OVAL G	2 (overlapped)
1/8	168-4-VG	3-G-887	3-G-887 HEAD	OVAL G	1
	18-3-M; 28-3-M; 188-4-VM; 428-4-VM	3-M-850	3-M-850 HEAD	OVAL M	1
		3V-CGMP; 3V-XPM; 3V-F6:X:M	3V-CGMP HEAD; 3V-XPM HEAD; 3V-F6:X:M HEAD	OVAL M	2
		3-MJ	3-MJ HEAD	M	2
5/32	168-5-VM	3-M-850	3-M-850 HEAD	OVAL M	2 (overlapped)
	18-4-P; 28-4-P; 188-5-VP; 428-5-VP*	3-P-850	3-P-850 HEAD	OVAL P	1*
		3V-CGMP; 3V-XPM	3V-CGMP HEAD; 3V-XPM HEAD	OVAL P	2
3/16	18-6-X; 28-6-X; 188-6-VX; 428-6-VX	3-X-850; 3V-XPM; 3V-F6:X:M	3-X-850 HEAD; 3V-XPM HEAD; 3V-F6:X:M HEAD	OVAL X	2
7/32	168-7-VX	3-X-950	3-X-950 HEAD	OVAL X	4
	18-8-F2; 28-8-F2; 428-7-VF2	3-F2-850	3-F2-850 HEAD	OVAL F2	2
* 1/4	168-8-VF2	3-F2-950	3-F2-950 HEAD	OVAL F2	5
	18-10-F; 28-10-F6; 188-8-VF6; 428-8-VF6	3-F6-950; 3V-F6:X:M	3-F6-950 HEAD; 3V-F6:X:M HEAD	OVAL F6	3
5/16	18-13-G9; 28-13-G9; 428-10-VG9	3-G9-950	3-G9-950 HEAD	OVAL G9	4
	188-10-VG92	3-G9-950	3-G9-950 HEAD	OVAL G9	4
3/8	18-23-H5; 28-23-H5; 428-12-VH5	3-H5-950	3-H5-950 HEAD	OVAL H5	4
	188-12-VH5	3-H5-950	3-H5-950 HEAD	OVAL H5	4

* Knight products utilized.

Continued on next page.

ACCESSORIES (CONTINUED)

Nicopress Safety Cabling Components Installation**NOTES AND SAFETY REMINDERS**

Sleeve pressing with No. 63V-XPM/Cutter tool or No. 64-CGMP/Cutter tool is done the same way as with No. 63V-XPM tool or No. 64-CGMP tool respectively.

Proof testing is recommended whenever the possibility of personal injury or property damage exists. ALWAYS WEAR SAFETY GLASSES WHEN TOOL IS BEING USED.

Nicopress hand tools are designed to be used with Nicopress sleeves. Swaging non-Nicopress sleeves, other materials and other items should not be attempted as it may cause damage to equipment and/or injury to personnel.

ADJUSTMENT FOR HAND TOOLS

Open handles, loosen locking screw two turns. Turn adjustment screw 1/4 of a turn clockwise. After adjustment, tighten locking screw. Swage sleeve on wire and check with gauge. Repeat if necessary. Clean and oil periodically. Except for some spring at final closing, "empty" tool should work freely. The No. 17-BA and 17-B4B tools are not adjustable.

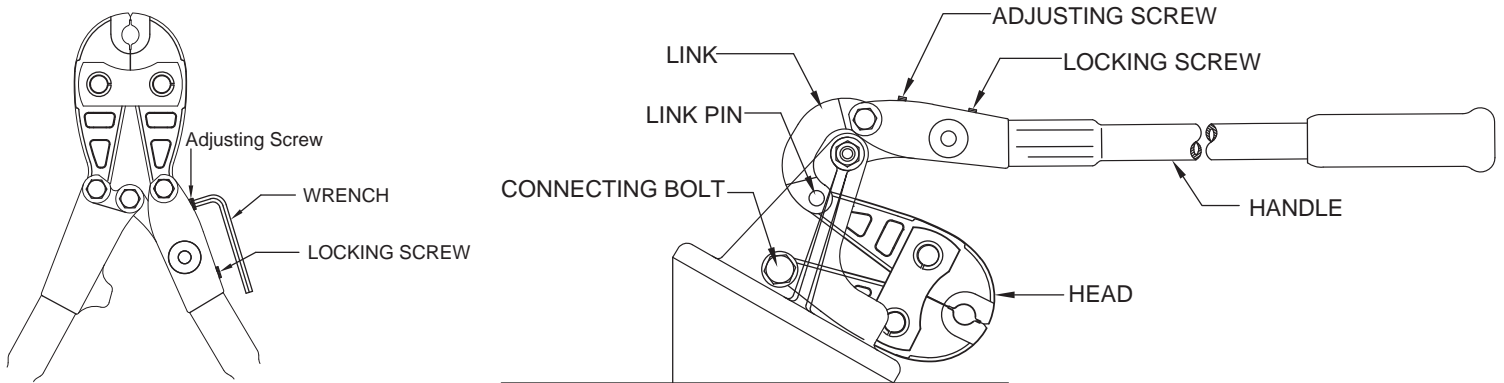
**NO. 300 BENCH TOOL AND NO. 510 BENCH TOOL: ADJUSTING AND CHANGING HEADS**

To remove the tool head: (1) Raise the handle to full open position. (2) Remove connecting bolt (see illustration). (3) Pull head out to expose link pin and remove it. To install a tool head, follow the reverse of this procedure. Always check tool adjustment when changing heads (see below).

To adjust the tool, raise the handle to the full open position, loosen the locking screw two turns. Turn adjustment screw 1/4 of a turn clockwise. After adjustment, tighten locking screw. Swage sleeve on wire and check with gauge. Repeat if necessary. Clean and oil periodically. Except for some spring at final closing, "empty" tool should work freely.

Continued on next page.

ACCESSORIES (CONTINUED)

Optional Safety Cabling - Eyebolt Method

Part Number(s): FDA4133

Parts List

- (2) Safety Cables (1/4" galvanized cable)
- (8) Crosby® Clamps
- (4) Cable Thimbles
- (2) 3/8" x 4 1/2" Eye Bolts

Eye Bolts

- Step 1. Use rail mounting bracket as template to mark rail. See Figure 3-152.
- Step 2. Drill two (2) holes using 13/32 in (11 mm) drill bit. Do not attempt to drill holes in-line. See Figure 3-152.
- Step 3. Install two (2) 3/8" x 4 1/2" Eye Bolts (alternating sides), (4) flat washers and (2) M10 nylock nuts. **Tighten until snug.**

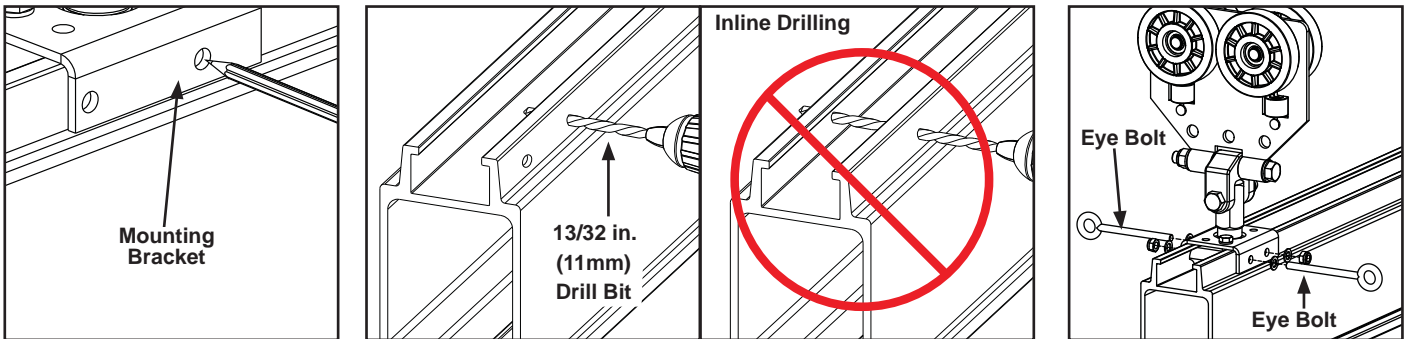

Figure 3-152

NOTE

- Do not overlap cable ends. Use eye method with thimbles. See Figure 3-145 ,Page 3-45.

Safety Cable

- Step 1. Insert first safety cable through bottom center hole of trolley plate and feed through hole of eye bolt.
- Step 2. Insert second safety cable through bottom center hole of trolley plate and through hole of other eye bolt.
- Step 3. Refer to page 3-45 for installing cable saddles.

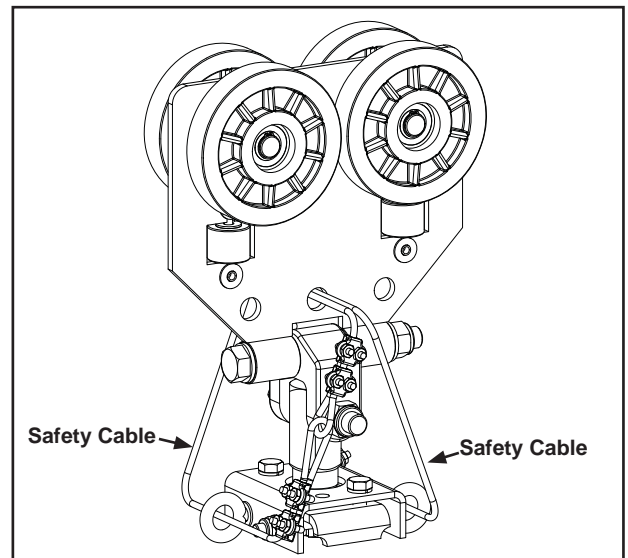

Figure 3-153

4. MAINTENANCE

Inspection Record Requirements

Duty Rating

Inspection frequency should be determined by a qualified person and is based upon duty service as defined below. Each rail system should be rated individually and inspections performed in accordance with rating. Inspections can be performed by qualified personnel.

Duty Service

Normal - Operation with uniform loads less than 65% of rated load for not more than 25% of time.

Heavy - Operation within rated load limit, which exceeds normal service.

Severe - Service that involves normal or heavy service with abnormal conditions.

Frequency of Documentation

Frequent Inspection (Non-Documented):

- Normal Service - quarterly
- Heavy Service – monthly.
- Severe Service - daily

“Rail Inspection Checklist”

“Rail Inspection Checklist” can be used as documentation sheet for new installations as well as to schedule routine maintenance. Use one sheet for each system inspected, additional forms can be copied from this booklet. Periodic maintenance should be performed every six months or more frequently depending on usage and environment. Inspect each system from “Item to be Checked” column. Fill in “Date Checked and “Checked by” columns to indicate that an inspection has been done and record any discrepancies that may appear. If any instructions or criteria are not clear, refer to applicable product page in this manual to help clarify.

Turn in a copy of completed checklist to supervisor for recording maintenance schedule and record keeping purposes.

Use one sheet for each system inspected, additional forms can be copied from this booklet, or download from our website: www.knightglobal.com/brochures/knight_rail_installation_checklist.pdf.

Periodic maintenance should be performed every six months or more frequently depending on usage and environment.

RAIL INSPECTION CHECKLIST				DATE:			
Work Cell Identification/Location:							
Rail-Type/Size:	Aluminum			2"	4"	6"	8"
What type of hangers?			How many hangers?				
Bridge?	Yes / No	Single / Dual	Notes:				
What type of load?	Direct	Cantilevered	Notes:				
Application:						Cycle Time:	

Item to be Checked	Date Checked	Checked by	Notes/Discrepancies/Comments
GENERAL			
Ensure all safety devices e.g., safety wire, safety cables, clips, pins, lock-nuts, etc. are properly installed.			
Safety cables installed at all hanger locations per rail section, ¼ in (.25 mm) cable with four (4) clips per cable. Cable clip saddles must be on "live" cable.			
Check all rail splices. Bolts should only be tightened " snugly "; over-tightening may cause bolts to strip out of splice plate.			
Ensure that each rail splice bracket is installed on top of rail at splice area with safety bolt holes drilled and bolts installed.			
For all types of rail, ensure that hanger / splice guidelines are followed.			
Visually check all fasteners for indications of over-torquing, especially on hanger pivot points and any other points where movement is required.			
Ensure hanger clamp alignment is perpendicular to beam and that bolts are not over torqued.			
Verify that hanger span is within guidelines for system capacity rating.			
Where applicable, check floor support base mounting bolts for presence and tightness.			

RAIL INSPECTION CHECKLIST (CONTINUED)

Item to be Checked	Date Checked	Checked by	Notes/Discrepancies/Comments
Mid-Rail Stop			
Rubber Bumper – Wear not to exceed .250 in (6.35 mm); safety cable properly attached.			
End Caps (polyurethane)			
Wear not to exceed - 7510 & 6110 =.325 in (8.25 mm); 4110 & 2000 =.125 in (3.175 mm)			
Trolley Wheels			
Inspect wheels, side rollers, axles, nut and hardware for security and damage, replace as needed. Inspect cable on end truck for wear or breakage.			
Load Eyes (Crane Eyes), Load Hooks			
Bent or distorted components; more than 5% wear in hook throat, wear greater than 5% of original diameter on bolts or pins, loose or damaged locking gates, any visible twisting of hook or eye.			
Hangers (Rod and Ball type)			
Wear resulting in $\geq .125$ in (3.175 mm) reduction of ball diameter; $\geq .125$ in (3.175 mm) increase in socket diameter or , $\geq .125$ in (3.175 mm) combined ball and socket wear.			
Hangers (Rigid/Semi-Rigid)			
Visible distortion, cracks; $\geq .250$ in (6.35 mm) increase in bolt hole diameter(s).			
Rail			
Gouges on running surface; twisting of more than $\geq .125$ in (3.175 mm) bend in excess of $\geq .125$ in (3.175 mm) in any span of any plane.			
Installation			
Straightness-Must be straight within $\frac{1}{4}$ in (6.4 mm) in any span length.			
Splice Gap-Must not exceed $\frac{1}{16}$ in (1.6 mm) at load carrying flange.			
Runway Elevation-Should not vary $\pm \frac{1}{4}$ in (6.4 mm) in any span length.			
Runway Parallelism-Must not exceed $\pm \frac{3}{16}$ in (4.8 mm).			

5. TROUBLESHOOTING

Rails Troubleshooting Chart

Refer to previous sections in this manual for specific installation instructions.

Problem	Cause	Solution
Load does not roll well along entire length of runway.	Runways	Ensure runways are parallel and level along length and across width of span. Install hangers that will pivot between structures and runway track. Loosen over-tightened bolts if binding at end caps.
	Splice sections	Ensure splices are installed per OEM instructions.
	Trolleys	Ensure trolley guide rollers and load wheels are in good condition and clean.
	Splice sections	Ensure splice sections are tight. Loosen over-tightened bolts if binding at end caps, hangers or trolleys.
	Bridges	Free up resistance from attached components.
	Rails	Ensure rail is damage free.
Bridge skews or rotates on horizontal axis (changes from a rectangle to a parallelogram) and binds up or is difficult to push or pull.	Runways	Ensure both runway rails are free to pivot along axis at hanger attachment points.
	Trolleys	Ensure trolleys are damage free. Ensure trolleys are free to pivot between trolley and hoist or carriage frames.
	Rails	Ensure rail is damage free.
Load settles in center span of a bridge or runway and does not remain parked at intervals along bridge length.	Fixture Carriage	Ensure attached components such as coiled tubing, electrical cables, or hoses move freely.
	Bridges	
	Rails	Ensure support spans are correct per system layout. Ensure that load does not exceed system rated capacity. (Refer to: http://www.knightglobal.com/rails for rated capacity charts.)
Fixture, hoist, arm, bridge trolleys continually wear out.	Runways	Ensure both runways are free to pivot along axis at hanger attachment points. Loosen over-tightened bolts if binding at end caps, hangers or trolleys.
	Trolleys	Ensure trolley is correct model for rail. Ensure trolleys are not rigidly mounted.
	Spliced Sections	Ensure splices are installed per OEM instructions.
	Hangers	Ensure correct hangers have been used on the proper system.
	Rails	Ensure rail is damage free.
		Wipe rolling surfaces of rail with a clean dry rag.

Rail Performance may be affected by various factors. If your rail system is not performing as well as expected, contact Knight Global at: 248-377-4950 or visit our website at www.knightglobal.com.

6. SPARE PARTS

For Spare Parts or Replacement parts visit Knight Global at: <http://www.knightglobal.com/rails>. Or contact Knight Global direct.

7. DECOMMISSIONING OF A RAIL SYSTEM



WARNING

Knight Global Enclosed Track Rail Systems must only be decommissioned by qualified personnel.

Knight Global Enclosed Track Rail System contain various materials which, at end of service life, should be disposed of or recycled, in accordance with local regulations

8. PERFORMANCE WARRANTY

Knight warrants that its products and parts shall meet all applicable specifications, performance requirements, and be free from defects in material and workmanship for one year, (Servo Systems for (2) two years, Pneumatic Lift Tables for (5) five years), from the date of invoice, unless otherwise noted.

Knight warrants the Servo Hoist, Arms, and Tractors to be free from defects in material or workmanship for a period of two years or 6000 hours use from the date of shipment.

On design and build jobs, the customer is the owner of the equipment once they authorize shipment. The purchased equipment cannot be returned for reimbursement or credit.

Exclusions

This warranty shall not cover the failure or defective operation caused by inadequate training provided by customer regarding the operation and/ or maintenance of the tool, misuse, negligence, misadjustment, or any alteration not approved by Knight Global. Knight's obligation is limited to the replacement or repair of Knight's products at a location designated by Knight Global. Buyer is responsible for all associated internal removal and reinstallation costs as well as freight charges to and from Knight Global. Knight's maximum liability shall not in any case exceed the contract price for the products claimed to be defective.

Any field modification made to Knight Products or Systems without the written authorization by Knight Global shall void Knight's warranty obligation.

Any purchased components not manufactured by Knight Global and their specific individual warranties are not covered. Paint defects, scratches and marring from shipping are also excluded on all Knight Global products and products not manufactured by Knight Global.

Knight Distributors/ Agents are not authorized to circumvent or change any of these terms and/ or conditions of this warranty unless prior approval is received in writing by Knight Global Management. Verbal statements made by Knight Distributors/ Agents do not constitute warranties.

Disclaimer

OTHER THAN AS SET FORTH HEREIN, NO OTHER EXPRESSED WARRANTIES, AND NO IMPLIED WARRANTIES, ORAL AND WRITTEN, INCLUDING BUT NOT LIMITED TO THE WARRANTIES OF MERCHANTABILITY OR FITNESS FOR A PARTICULAR PURPOSE, ARE MADE BY KNIGHT GLOBAL WITH RESPECT TO ITS PRODUCTS AND ALL SUCH WARRANTIES ARE HEREBY SPECIFICALLY DISCLAIMED.

KNIGHT GLOBAL SHALL NOT BE LIABLE UNDER ANY CIRCUMSTANCES FOR ANY INCIDENTAL, SPECIAL AND/OR CONSEQUENTIAL DAMAGES WHATSOEVER, WHETHER OR NOT FORESEEABLE, INCLUDING BUT NOT LIMITED TO DAMAGES FOR LOST PROFITS AND ALL SUCH INCIDENTAL, SPECIAL AND/OR CONSEQUENTIAL DAMAGES ARE HEREBY ALSO SPECIFICALLY DISCLAIMED.

KNIGHT GLOBAL WILL NOT BE LIABLE FOR ANY LOSS, INJURY OR DAMAGE TO PERSONS OR PROPERTY, NOR FOR DAMAGES OF ANY KIND RESULTING FROM FAILURE OR DEFECTIVE OPERATION OF ANY MATERIALS OR EQUIPMENT FURNISHED HEREUNDER.

ISO 14001:2015



ISO 9001:2015

APPENDIX

Enclosed Track Rail Specs. (Meets or exceeds ANSI MH27.2)

- | | |
|------------------------------------|---|
| 1. End Squareness – | Must be square to running surface within 1/32 in (.7925 mm) |
| 2. Straightness – | Must be straight within 1/4 in (6.35 mm) over a 20ft (6.096 m) span |
| 3. Splice Gap – | Must not exceed 1/16 in (1.5872 mm) between rail spans |
| 4. Runway Elevation – | Must not exceed $\pm 1/4$ in (6.35 mm) over a 20ft (6.096 m) span |
| w/Servo XY System – | Must not exceed $\pm 1/16$ in (1.5872 mm) over a 20ft (6.096 m) span |
| 5. Runway Parallelism – | Must not exceed $\pm 3/16$ in (4.7265 mm) in any span length |
| w/Servo XY System – | Must not exceed $\pm 1/16$ in (1.5872 mm) in any span length |
| 6. Runway rail to rail elevation – | Must not exceed $\pm 1/8$ in (3.175 mm) over a 10ft (3.048 m) runway span |
| w/Servo XY System – | Must not exceed $\pm 1/16$ in (1.5872 mm) over a 10ft (3.048 m) runway span |

Runway and Monorail Alignment Tolerances

1. Establish point of reference and make all measurements relative to that point
2. Parallelism measurements taken from center line of rail profile.
3. Elevation measurements taken from bottom of rail.

1. Squareness

The tolerance shown below is for squareness of rail ends in any direction.

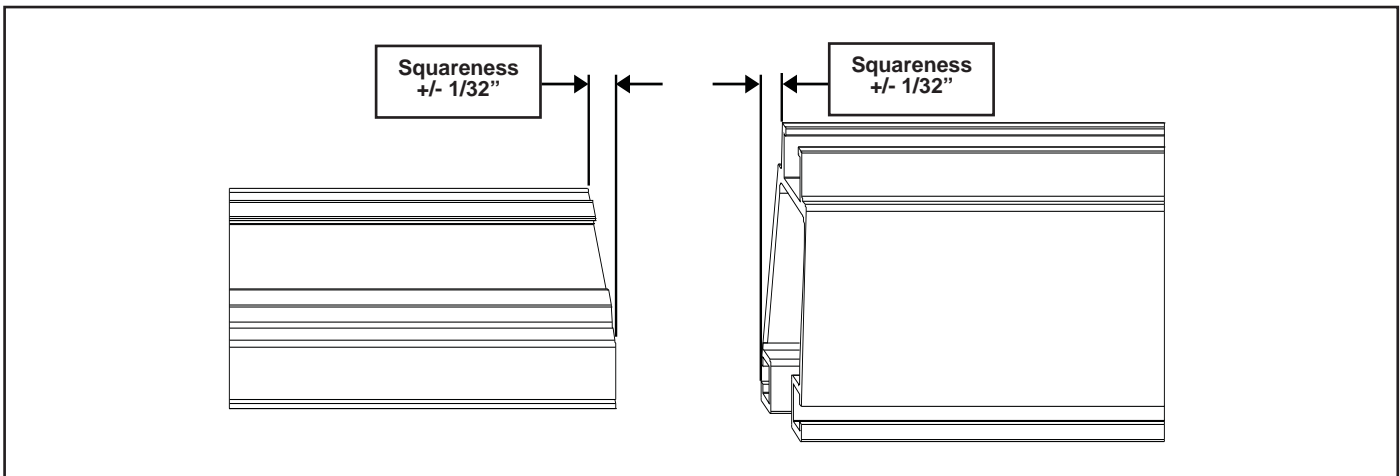

2. Straightness

The tolerance shown below is the plan view of a rail length. Straightness tolerance applied to overall length of a single line of runway, or a monorail line. Centerline of hangers must be $\pm 1/4"$. **NOTE: This does not apply to curved rail.

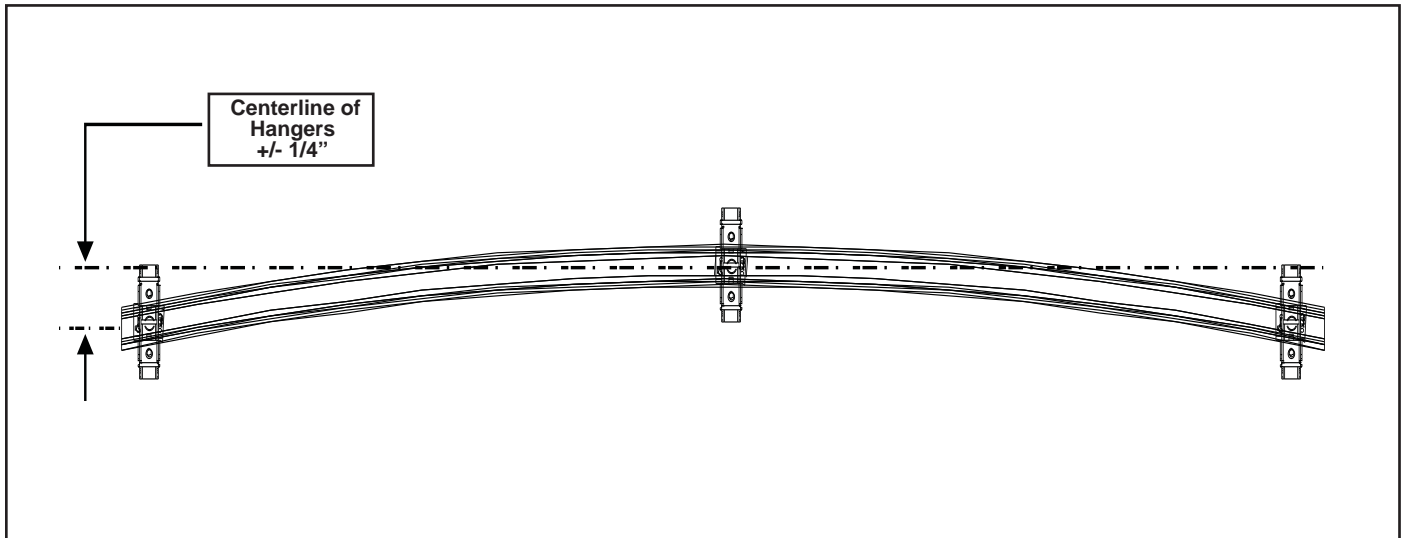

3. Splice Gaps

The tolerance shown below is for when a rail length must be spliced together.

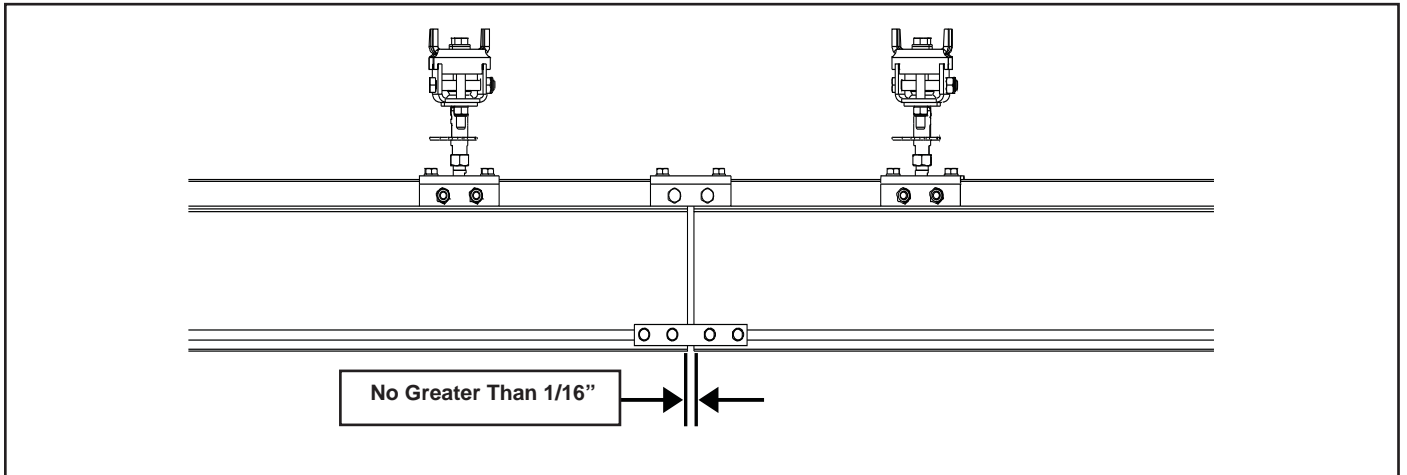

4. Runway Parallelism

The tolerance shown below is for two runways, and also for three or more runways.

Dimensions measured at hanger points.

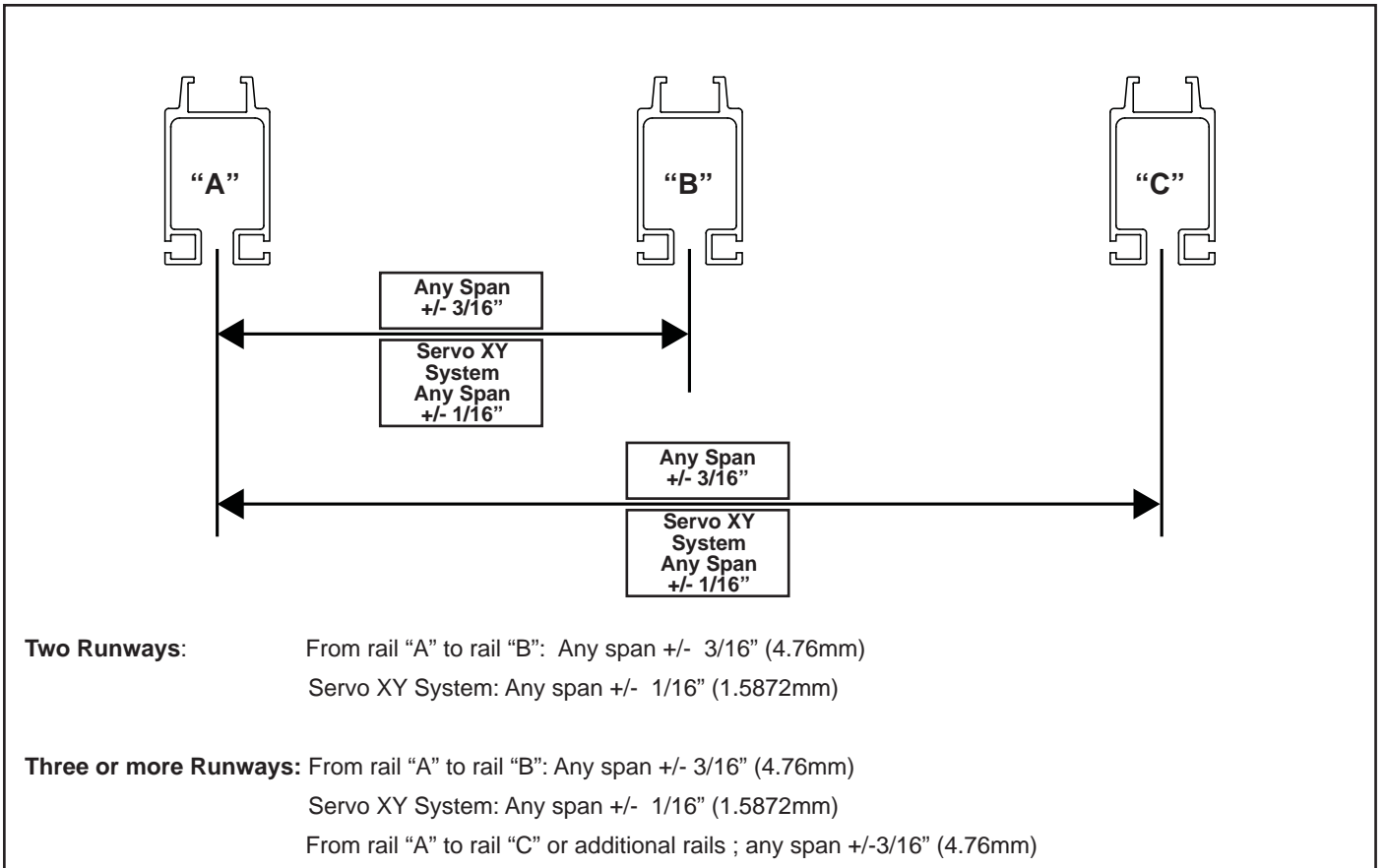

5. Elevation

The tolerance shown below is for elevation of a single line of runway, or a monorail line, measured at adjacent in-line hanger points.

Also applies to overall length of runway or monorail (tolerances do not accumulate over the length of the run)

Does not apply to systems designed to operate on an incline

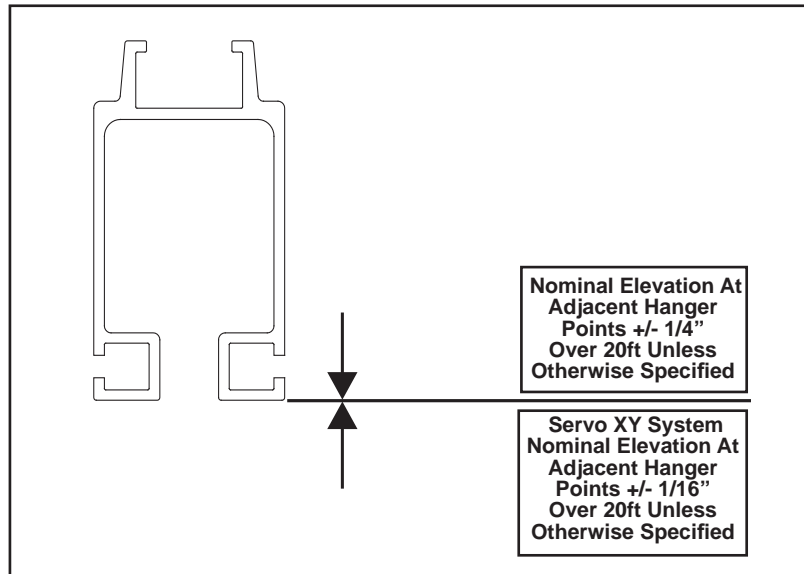

6. Rail to Rail Elevation

The tolerance shown below is for elevation of adjacent lines of runway, measured at adjacent hanger points starting at a 0 Point.

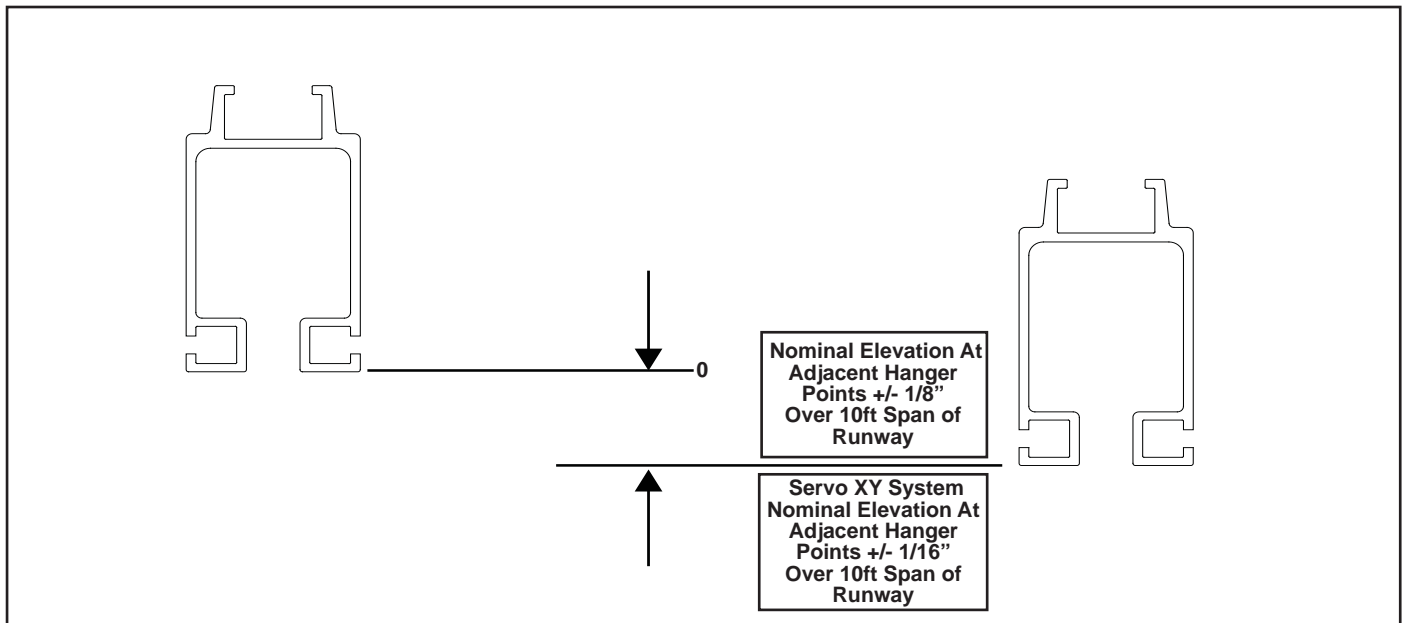

Splice Kit Hanger Location

For RAD 7510, RAD 6110 and RAD 4110 series aluminum rail hanger location is based on rail layout and application i.e., there should be a hanger either directly over or within 18" (457mm) of either side of splice. Each section of rail must be supported by at least two (2) hangers. (A splice is not considered a hanger.) Refer to figure below.

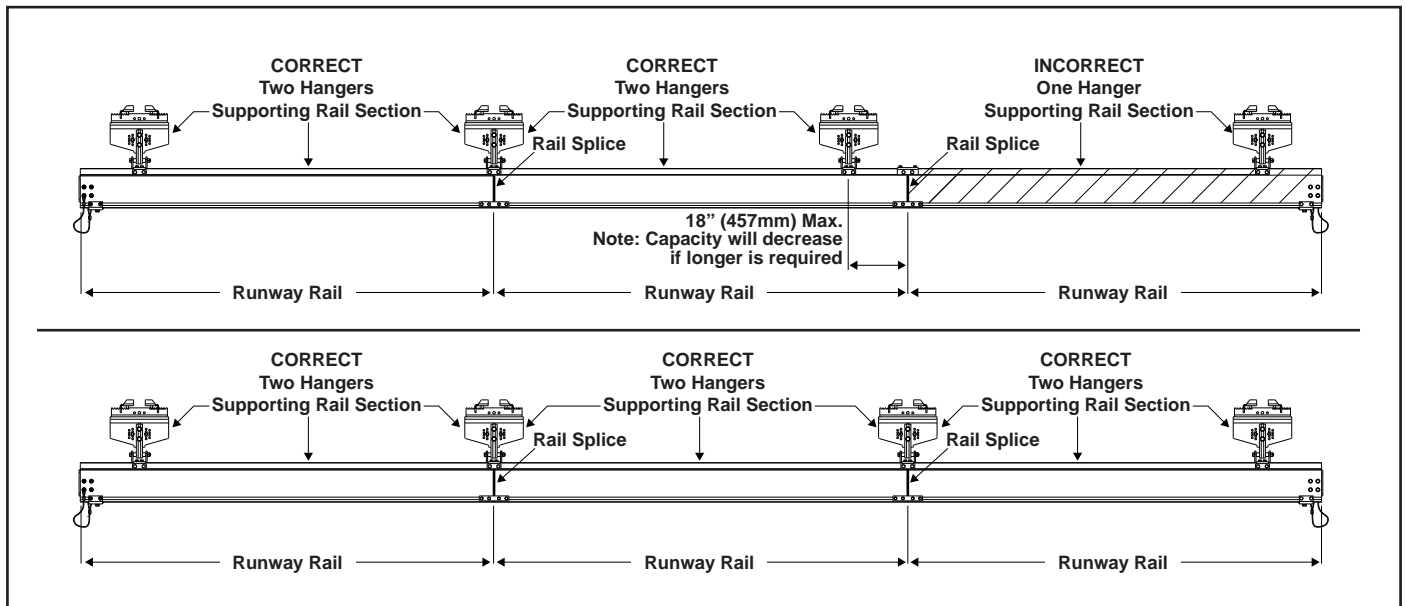



KNIGHT GLOBAL

KNIGHT GLOBAL

2705 Commerce Parkway

Auburn Hills, MI 48326

Phone 248-377-4950 | Fax 248-377-2135

For additional copies\literature e-mail: sales@knightglobal.com

For service related requests e-mail: service@knightglobal.com

www.knightglobal.com

May 2024