

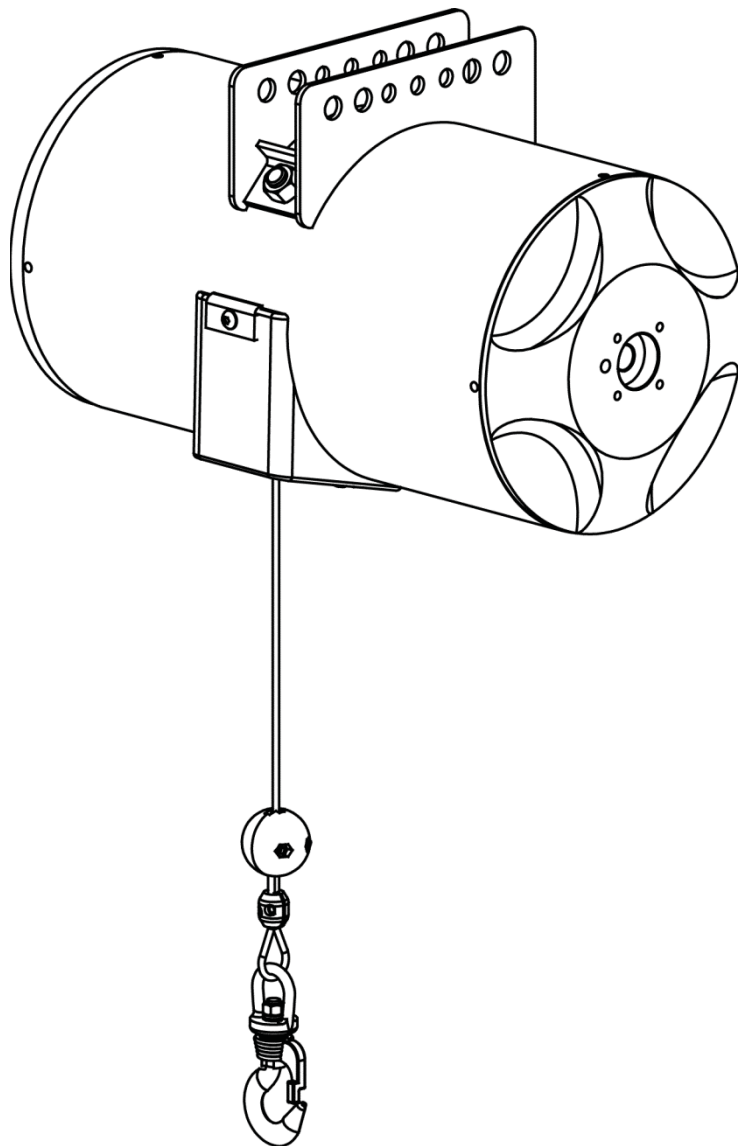

Pneumatic Balancer Operation Manual



THIS MANUAL CONTAINS IMPORTANT INFORMATION REGARDING INSTALLATION, SAFETY, MAINTENANCE, AND OPERATION OF KNIGHT GLOBAL PNEUMATIC BALANCERS AND SHOULD BE AVAILABLE TO ALL PERSONNEL RESPONSIBLE FOR USING THE BALANCER.

This manual provides important information for all personnel involved in the installation, operation and maintenance of the Knight Global pneumatic balancer. All personnel must read this document before operating the equipment.

Every effort has been made to provide complete and accurate product information in this manual. However, due to product improvements and changes, discrepancies and omissions may be present. Visit our website at www.knightglobal.com for the updated information on all our products.

It is the responsibility of the end user to exercise common sense and judgment when performing the tasks described in this manual. If any procedure seems inaccurate, incomplete or unsafe please put the equipment in a safe condition and contact Knight Global service department for assistance.

Throughout this manual there are steps and procedures that if not performed correctly can result in personal injury or equipment damage. The following signal words are used to identify the level of potential hazard.

**WARNING!**

Indicates a hazard which will cause severe injury, death or substantial equipment damage.

**CAUTION!**

Indicates a hazard which can or will cause injury or equipment damage.

NOTE

Notifies personnel of installation, operation or maintenance information which is important but not hazard related.

1. SAFETY	1
General Safety Precautions.....	1
Warning Label.....	2
Safety Devices.....	3
Internal Retract Control	3
External Retract Control	3
2. INSTALLATION	4
A. Positioning and Height	5
Minimum Installation Height.....	5
Maximum Install Height.....	6
Balancer Positioning	6
B. Load Hook Installation.....	7
C. Swivel Shackle Installation.....	8
D. Reeving Block (Cable) Installation	9
E. Reeving Block (Chain) Installation	9
F. Control Module Installation.....	10
Up / Down Pendant.....	10
Dual Balance.....	11
Single Balance	11
High Relieving Single Balance.....	12
Feather Touch Control	13
G. Trolley / Top Hanger Hook Installation.....	14
Rail Trolley	14
Top Hanger Hook.....	14
H. I-Beam Trolley	15
I. Safety Cable Installation	16
J. End of Travel Indicator Placement (Ball Stop).....	16
K. Connecting Main Air	17
3. OPERATION	18
A. Principle of Operation.....	18
B. Model Number.....	18
C. Balancer Sizing	19
Load Capacity	19
Formula for Air Balancer sizing:.....	19
Balancing a Load	19
4. MAINTENANCE	20
A. Chain / Cable Inspection	20
4.1 INSPECTIONS	20
4.1.1 Chain / Cable Inspection Overview.....	20
4.2 Use of Chain/Cable Safely in Any Application.....	21
4.3 Determining the Frequency of Chain/Cable Inspections.....	22
4.3.1 Service Rating Load Criteria	22
4.3.2 Service Class (Duty Cycle)	22
4.4 Type of Inspections	23
4.4.1 Frequent Inspection (Visual).....	23

4.4.1.1 Ideas Regarding What to Look for During A Frequent Inspection	23
4.4.2 Periodic Inspection (Documented).....	24
4.4.2.1 Recommendations for Periodic Inspections of Chain (KBC)	24
4.4.2.2 Recommendations for Periodic Inspections of Cable (KBA).....	26
4.4.2.3 Recommended Record Keeping for Periodic Inspections	27
4.4.3 Chain/Cable Lubrication:.....	28
4.5 Cable Replacement	29
4.6 Chain Replacement	32
B. PREVENTATIVE MAINTENANCE FOR KNIGHT BALANCERS	34
4.7 Balancer Inspections	34
4.7.1 Recommendations for Frequent Inspections for Balancers (Visual)	34
4.7.2 Periodic Inspection (Documented).....	35
C. Adjustments.....	37
4.8 Operation Adjustments	37
4.8.1 Pendant Control	37
4.8.2 Dual Balance.....	37
4.8.3 Single Balance	38
4.8.4 High Relieving Single Balance.....	38
4.8.5 Feather Touch Control	39
4.8.6 Drift Adjustment	39
D. Internal Retract Control	40
4.9 Resetting Internal Retract Control	40
4.9.1 Pendant Control	40
4.9.2 Single Balance / Dual Balance	40
5. TROUBLESHOOTING	41
6. SPARE PARTS LIST	41
7. DECOMMISSIONING OF AN AIR BALANCER.....	41
8. KNIGHT'S PERFORMANCE WARRANTY	42

1. SAFETY

Knight Global recognizes that most companies have a safety program in place at their facility. The Safety Section, Notes, Cautions and Warnings in this manual are intended to supplement and not supersede any existing plant or company safety guidelines or regulations.

Knight Global cannot be aware of or provide for all the procedures by which the balancer operations or repairs may be conducted and the hazards which may result from each method. If operation or maintenance not specifically recommended by Knight Global is conducted, it must be ensured that product or personnel safety is not endangered by these actions. Personnel should place the balancer in a safe condition and contact a supervisor and/or Knight Global's service department for technical support if they are not sure of an operation, maintenance procedure, or step.

General Safety Precautions

- Do not operate balancer before reading this technical manual.
- Only allow personnel trained in safety and operation of this balancer to operate the balancer.
- If the balancer is locked out or a "DO NOT OPERATE" sign is on the balancer or controls do not operate the balancer until the lock or sign is removed by designated personnel.
- Do not use the balancer if hook latch has been sprung or broken.
- Ensure the hook latches are engaged before using.
- Before each shift or prior to use inspect the balancer in accordance with the procedures defined in the maintenance section of this manual.
- Never place your hand or fingers inside the throat area of a hook.
- Never use the cable as a sling.
- Never operate a balancer with twisted, kinked or damaged cable or chain.
- Only operate a balancer when the cable or chain is centered over the hook. Do not "side pull" or "yard".
- Do not force the hook into place by hammering.
- Ensure the load is properly seated in the saddle of the hook.
- Never run the cable or chain over a sharp edge.
- Pay attention to the load at all times when operating the balancer.
- Ensure no personnel are in the path of the load.
- Do not lift the load over personnel.
- Never use a balancer for lifting or lowering people.
- Do not allow anyone to stand on a suspended load.
- Do not swing a suspended load.
- Never leave a suspended load unattended.
- Never cut or weld a suspended load.
- Do not operate a balancer if the cable or chain is jumping, jamming, overloading or binding or if there is excessive noise.
- Avoid collisions or bumping of the balancer.
- Do not operate balancer when damaged or malfunctioning.
- Ensure that the chain is properly lubricated before operation of KBC balancer models.
- Do not operate the balancer with twisted, kinked, frayed or damaged cable.
- Do not remove load or handling device until tension is released from the cable or chain.
- If the internal retract ratchets when engaged discontinue use and inform maintenance.

Warning Label

Each unit is shipped from Knight Global with a warning label affixed (See Figure 1-1). This label is provided to ensure all personnel operating this balancer are informed of specific safety concerns. If the label is missing, contact Knight Global for a replacement.

 ADVERTENCIA	 WARNING
<p>Si no respeta estas advertencias puede ocasionar lesiones físicas severas, fatales o daños materiales.</p> <ul style="list-style-type: none"> • No haga funcionar el balancador antes de leer el manual de operación y mantenimiento.  • No haga funcionar el balancador si está dañado o funciona mal. • No levante más de la capacidad nominal. • No haga funcionar la unidad con cuerda de alambre o cadena dañada, deshilachada, doblada o torcida. • No levante personas ni cargas por encima de la gente. • No retire la carga ni manipule el dispositivo hasta que la tensión se libere de la cuerda de alambre o cadena. • No quite ni cubra la etiqueta de advertencia. 	<p>Failure to follow these warnings may result in death, severe injury or property damage.</p> <ul style="list-style-type: none"> • Do not operate balancer before reading operation and maintenance manual.  • Do not operate balancer when damaged or malfunctioning. • Do not lift more than rated capacity. • Do not operate with twisted, kinked, frayed or damaged wire rope or chain. • Do not lift people or loads over people. • Do not remove load or handling device until tension is released from wire rope or chain. • Do not remove or obscure warning label. <p style="text-align: right; font-size: small;">saf-006-eng-spn</p>
 KNIGHT KNIGHT GLOBAL AUBURN HILLS, MI USA (248) 377-4950	 KNIGHT KNIGHT GLOBAL AUBURN HILLS, MI USA (248) 377-4950

Figure 1-1

Safety Devices

Internal Retract Control

The internal retract control is standard equipment on Knight Global balancers. Without retract control a whipping cable could possibly injure personnel. If the load is lost suddenly and/or the hook or cable fails, then the rapid upward acceleration causes centrifugal force to engage the brake dog into the grooves on the balancer liner. The retract control consists of the following items (See Figure 1-2): top retract plate, bottom retract plate, brake dog and resistance spring. The retract plates hold the brake dog in place and provides a mounting location for the resistance spring. The resistance spring holds the brake dog in the retracted position during normal operation.

Activation of the internal retract control is not instantaneous. The device requires a moment to accelerate to a speed that causes the brake dog to engage, normally after 2 to 4in. [50mm to 100mm] of cable travel.

External Retract Control

The external retract control is optional equipment on Knight Global balancers and consists of two hydraulic shocks mounted on the retract cap and a thrust bearing mounted on the balancer spool (See Figure 1-3). The hydraulic shocks provide constant resistance to spool rotation. If the load suddenly changes, the resistance prevents the spool from accelerating.

2 in.[50mm] of stroke length is lost when an external retract control is used due to the thrust bearing installed on the spool. Models with an external retract control do not have an internal retract control or brake installed. The external retract is factory set, adjustments should not be made by the user; if adjustments are required, contact the Knight Global service department.

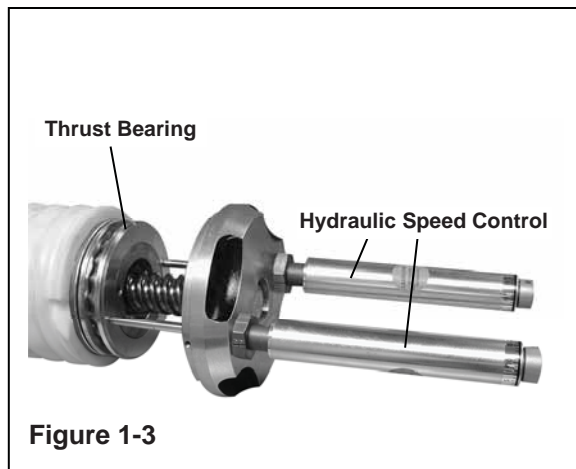
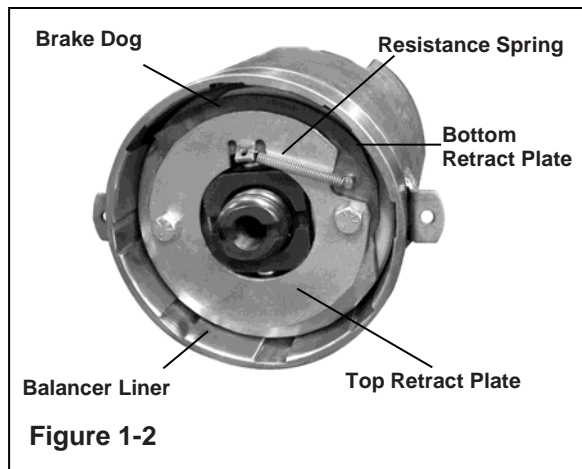

2. INSTALLATION

Prior to installation, visually inspect the air balancer for signs of damage.



CAUTION!

Prior to placing this unit into service the owners and user are advised to examine specific local and/or other regulations, including ANSI and OSHA regulations that may apply to the use of this product.



WARNING!

A falling load can cause injury or death. Before installing this balancer read the "Safety" section of this manual.



WARNING!

Do not operate without weight on end of the balance cable or chain. Doing so can cause damage to the balancer and/or operator.

Follow all procedures in this section for installation and set-up of the balancer.

Retain all product information supplied with the balancer for future reference.

Ensure that the supporting structure is able to support the weight of the system and load. The structure should be able to support 300 percent of the combined weight of the balancer and load. Do not use a supporting structure that tilts the balancer to one side or the other.

For safe and proper installation into a rail system, refer to the installation manual provided by the rail system manufacturer.

The air supplied to the balancer must be clean and free from water or oil. To achieve maximum rated balance capacity, 100 psi [6.9 bar] air must be applied to the balancer. Refer to page 19 "Balancer Sizing".

The inside diameter of the air lines supplying the balancer must not be smaller than 1/2 in. [12.7 mm] based on a maximum of 100 ft. [30 m] between the air supply and the balancer. Contact the Knight Global service department for recommended air line sizes for distances greater than 100 ft. [30 m]. The supply lines should be short and straight as conditions permit. Long supply lines and excessive use of fittings, elbows, tees etc. cause a drop in air pressure and flow due to restrictions and surface friction of the lines.

When installation is complete and prior to placing the air balancer into operation, inspect the air balancer following the "Periodic Inspection" procedure on page 34 of the "Maintenance" section.

A. Positioning and Height

Minimum Installation Height



WARNING!

If the system was designed by Knight Global, use the elevations from supplied drawings. Do not cut the cable or chain until correct travel is set.

- Step 1. Measure from the pick-up point to the highest obstruction for moving the part to the drop off point (See Figure 2-1 item A).
- Step 2. Measure the bottom of the part or fixture, whichever is the lowest point, to the hook attachment point. (See Figure 2-1 item B).
- Step 3. Subtract step 1 from step 2, the difference should be less than the stroke of the balancer indicated on the balancer retract cap (ex. KBA150-076, 076 is the balancer stroke). If the difference is greater than the stroke, then a balancer with a longer stroke must be used.
- Step 4. The minimum install height for the balancer at the balancer trolley mount holes is the sum of: dimension "C" (See Figure 2-1), obstruction height (See Figure 2-1 item A) and the part and bail height (See Figure 2-1 item B).
- Step 5. Standard lengths of 30 ft. [9.1 m] of cable or 15 ft. [4.6 m] of chain are supplied with balancers.

NOTE

Should longer chain length be required, contact Knight Global. (Additional chain length does not increase travel of balancer.)

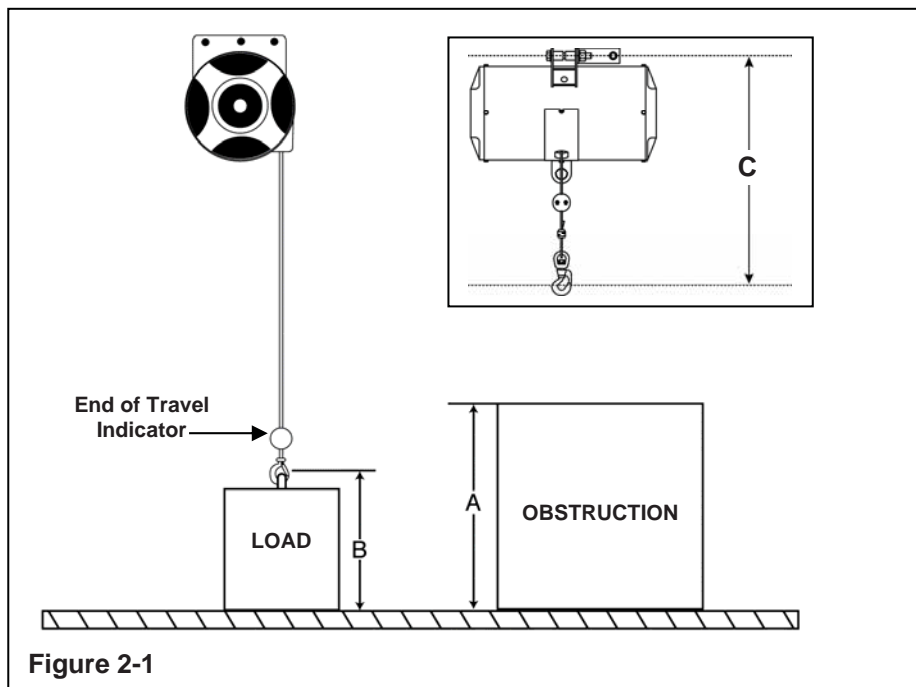

NOTE

The End of Travel Indicator (Ball Stop) is factory set and must not be moved. If replacement is necessary, refer to page 16 for instructions.

Maximum Install Height

The End of Travel Indicator (ball stop) prevents the cable or chain from continuing into the balancer after the spool has stopped. It **must not** be used as a travel stop and **must not** be moved from the factory set location. **Moving the End of Travel Indicator does not increase the stroke length of the balancer.** (See Figure 2-2)

Balancer Positioning

Position the balancer directly above the load; **the cable or chain should not yard more than 10 degrees** (See Figure 2-3). Excessive yarding will cause damage and premature wear to the balancer.

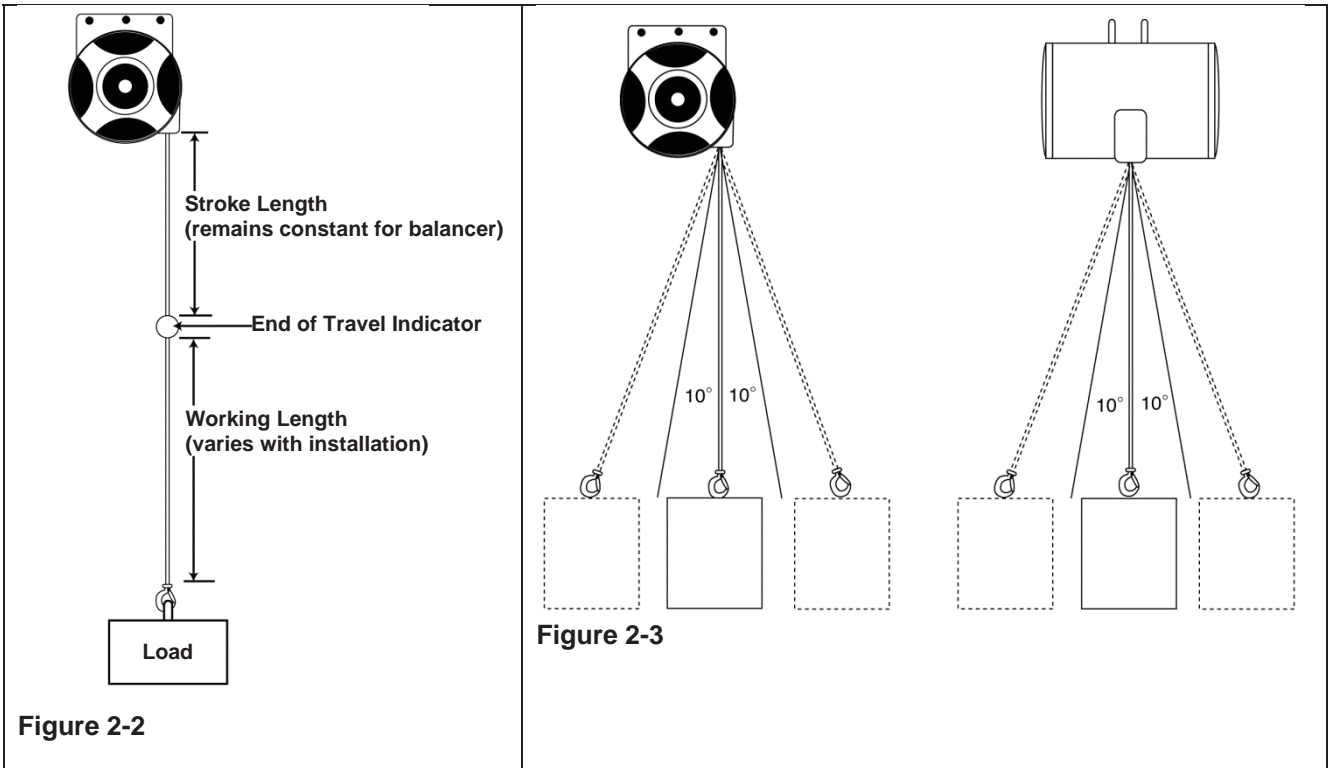

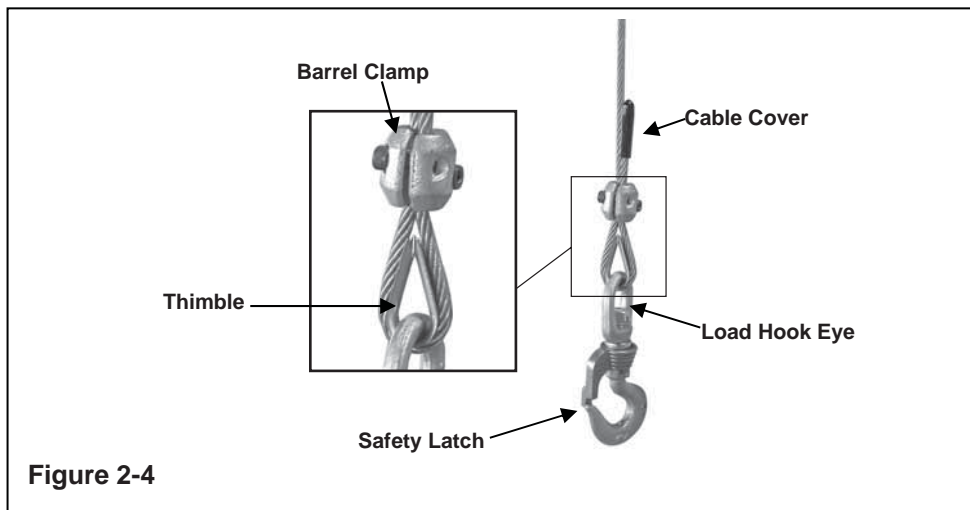

B. Load Hook Installation

Refer to Figure 2-4 throughout this procedure

- Step 1. Install the balancer onto rail or structure per manufacturer's instructions.
- Step 2. Slowly pull the cable out until fully extended. The length from the end of travel indicator to the cable guide should equal the stroke length on the model number (Refer to "Model Number" page 18).
- Step 3. Attach the fixture to the part. Ensure part is at lowest point of travel required.
- Step 4. Connect the load hook to the fixture. Ensure the hook is seated and the safety latch is fully closed.
- Step 5. Run the end of the cable through the load hook eye and pull until taut.
- Step 6. Release 2 in. [50mm] or more of slack in the cable. This will prevent the cable from being taut when attempting to release the part from the fixture.
- Step 7. Slip the cable thimble onto the load hook eye. The thimble may be opened to engage the hook eye. Do not bend the thimble more than required.
- Step 8. Lay the cable in the thimble and wrap the cable back onto itself above the hook forming an eye.
- Step 9. Remove the screws from the barrel clamp and attach the barrel clamp above the thimble, trapping both the "live" and "dead" cable in barrel clamp.
- Step 10. Tighten barrel clamp bolts, alternating between bolts until snug. After barrel clamp bolts are snug torque to 4.3 ft/lbs [5.83 nm].
- Step 11. Perform several cycles of the balancer with the fixture and part to ensure cable length is correct.
- Step 12. Check the barrel clamp bolts to ensure they are tightened to the proper torque value.
- Step 13. Trim excess cable approximately 1 in. [25mm] from the barrel clamp. Place a cable cover or tape over the end of the cable to prevent fraying.

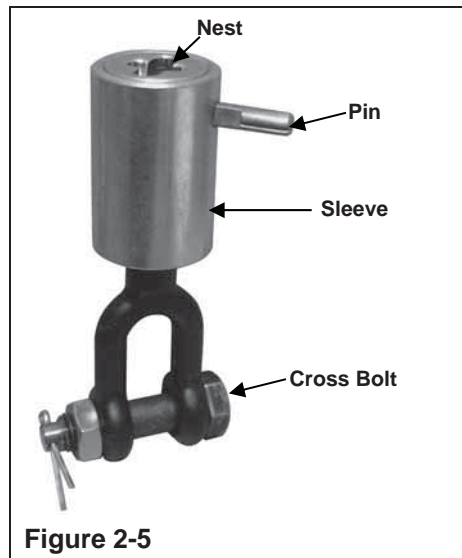

C. Swivel Shackle Installation

Refer to Figure 2-5 throughout this procedure

- Step 1. Install the balancer onto rail or structure per manufacturer's instructions.
- Step 2. Slowly pull the chain out until fully extended. The length from the End of Travel Indicator to the chain guide should equal the stroke length on the model number (See "Model Number" page 18).
- Step 3. Attach the fixture to the part. Ensure part is at lowest point of travel required.

NOTE

When attaching load, ensure free rotation of Cross Bolt.

- Step 4. Connect the swivel shackle to the fixture. Hand tighten the cross-bolt nut and install cotter pin.
- Step 5. Hold the hook upright and place chain alongside the swivel shackle assembly. Mark a chain link that is at least 2 in. [50mm] below the link that lines up with the pin. The extra length will prevent the chain from being taut when attempting to release the part from the fixture.
- Step 6. Cut the chain at the marked link with a bolt cutter or grinder.

NOTE

Before cutting the chain ensure the length is correct for the application. Extra chain length can be left if there are no height obstructions

! WARNING!

Use appropriate safety equipment when cutting the chain to prevent injury.

- Step 7. Insert the end link of the chain into the nest. Ensure the pin flats align with sides of the link.
- Step 8. Tap the pin into the nest and chain link. Ensure the pin engages the link and does not bind. Tap the pin completely through the nest until the pin end is flush with the sleeve.

D. Reeving Block (Cable) Installation

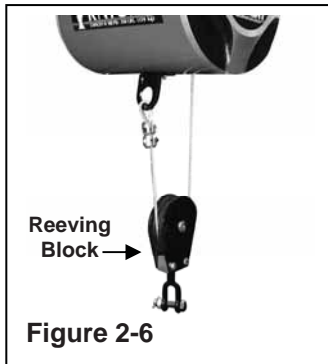

Refer to Figure 2-6 throughout this procedure.

- Step 1. Thread the cable through the reeving block. Ensure that the cable runs through the groove in the pulley.
- Step 2. Loosen barrel clamp bolts and slide the barrel clamps onto the cable.
- Step 3. Install the thimble onto the pad eye. The thimble may be opened to engage the pad eye, do not bend the thimble more than required.
- Step 4. Loop the cable through the hook bracket and thimble.
- Step 5. Thread the end of the cable back through the barrel clamp. Pull cable through until the load hook or shackle is at the proper level.
- Step 6. Release 2 in. [50mm] or more of slack in the cable. This will prevent the cable from being taut when attempting to release the part from the fixture.
- Step 7. Tighten barrel clamp bolts, alternating between bolts until snug. After barrel clamp bolts are snug, torque to 4.3 ft/lbs [5.83 nm].
- Step 8. Perform several cycles of the balancer with the fixture and part to ensure cable length is correct.
- Step 9. Check the barrel clamp bolts to ensure they are still tightened to the proper torque value.
- Step 10. Trim excess cable approximately 1 in. [25mm] from the barrel clamp, place cable cover over the end of the cable to prevent fraying.

E. Reeving Block (Chain) Installation

- Step 1. Thread the chain through the reeving block. Ensure that the chain runs through the groove in the pulley.
- Step 2. Bring chain up to the pad eye on balancer. Mark a chain link that is at least 2 in. [50 mm] below the link that lines up with the pad eye. The extra length will prevent the chain from being taut when attempting to release the part from the fixture.
- Step 3. Cut the chain at the marked link with a bolt cutter or grinder.

NOTE

Before cutting the chain, ensure the length is correct for the application. Extra chain length can be left if there are no height obstructions.

WARNING!

Use appropriate safety equipment when cutting the chain to prevent injury.

- Step 4. Install chain through sheave pulley. Attach chain to hook bracket using the anchor shackle Crosby Clamp.
- Step 5. Attach the swivel shackle to the pad eye.

F. Control Module Installation

The following installation steps cover the Control Module configurations listed below:

- Up / Down Pendant
- Single Balance
- Dual Balance
- High Relieving Single Balance
- Feather Touch Control

Up / Down Pendant

Part Numbers: BCS3017, BCS3320, BCS3330, BCS2326, BCS2231, BCS2327, BCS2091, BCS2321

Installation

- Step 1. Unpack and inspect manifold, hoses and pendant assembly for damage.
- Step 2. Remove tape on back of manifold that covers O-ring for shipping purposes. Check that the O-ring is seated into recess on back of manifold. If not, install provided O-ring.

NOTE

Air seal between the control module and balancer is required for proper operation.

- Step 3. Wipe the mounting surfaces with a damp cloth. Align the air outlet with the inlet on valve cap and attach control module to the valve cap with the four (4) provided bolts. Torque to 5 ft/lbs [6.8 nm].
- (Tandem only) Repeat step 3 to attach the slave manifold to the second balancer.
- Step 4. Follow appropriate steps below for 2 or 3 port manifolds.

Two Port:

- Step 1. Connect hose to the right side fitting (UP) on manifold; connect opposite end to "1" port on the pendant.
- Step 2. Connect hose to left side fitting (DOWN) on manifold; connect opposite end to "2" port on the pendant.

Three Port:

- Step 1. Connect one hose to the right side fitting (UP) on manifold, connect opposite end to right "OUT" port on the pendant.
- Step 2. Connect second hose to left side fitting (DOWN) on manifold, connect opposite end to left "OUT" port on the pendant.
- Step 3. Connect the third hose to the far right fitting on manifold; connect the opposite end to the center "IN" port on the pendant.

Bench Setting

- Step 1. Turn the drift adjustment screw (See Figure 2-7) counter-clock-wise until it stops (do not load) and turn back one half turn.
- Step 2. Turn the flow control screw marked UP clock-wise until seated (do not over tighten) and back off one full turn.
- Step 3. Turn the flow control screw marked DN clock-wise until seated (do not over tighten) and back off one full turn.
- Step 4. Control module is now bench set. Additional adjustments (Refer to page 37) will be required after connecting main air (Refer to "Connecting Main Air" page 17).

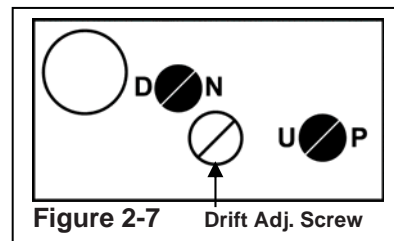

Dual Balance

Part Numbers: BCS2215, BCS2323

Installation

- Step 1. Unpack and inspect dual balance module, hoses and pendant assembly for damage.
- Step 2. Remove tape on back of manifold that that covers O-ring for shipping purposes. Check that the O-ring is seated into recess on back of manifold. If not, install provided O-ring.

NOTE

Air seal between the control module and balancer is required for proper operation.

- Step 3. Wipe the mounting surfaces with a damp cloth. Align the air outlet with the inlet on valve cap and attach control module to the valve cap with the four (4) provided bolts. Torque to 5 ft/lbs [6.8nm].
- Step 4. Connect one hose to the right side fitting (14) on the manifold, connect opposite end to right "OUT" port on the pendant. (See Figure 2-8)
- Step 5. Connect second hose to left side fitting (12) on the manifold, connect opposite end to "OUT" port on the pendant. (See Figure 2-8)
- Step 6. Connect the third hose to the far right fitting (P) on the manifold, connect the opposite end to the center "IN" port on the pendant. (See Figure 2-8)

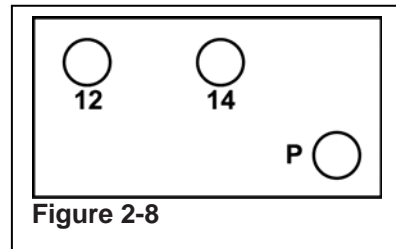

Figure 2-8

Bench Setting

- Step 1. Deplete the relieving regulators by turning knobs counter-clock-wise until they stop.
- Step 2. Control module is now bench set. Additional adjustments (Refer to page 37) will be required after connecting main air (Refer to "Connecting Main Air" page 17).

Single Balance

Part Number BCS2018

Installation

- Step 1. Unpack and inspect manifold and regulator assembly for damage.
- Step 2. Remove tape on back of manifold that that covers O-ring for shipping purposes. Check that the O-ring is seated into recess on back of manifold. If not, install provided O-ring.

NOTE

Air seal between the control module and balancer is required for proper operation.

- Step 3. Wipe the mounting surfaces with a damp cloth. Align the air outlet with the inlet on valve cap and attach control module to the valve cap with the four (4) provided bolts, torque to 5 ft/lbs [6.8 nm].

Bench Setting

- Step 1. Deplete the relieving regulator by turning the knob counter-clock-wise until it stops. (See Figure 2-9)
- Step 2. Control module is now bench set. Additional adjustments (Refer to page 38) will be required after connecting main air (Refer to "Connecting Main Air" page 17).

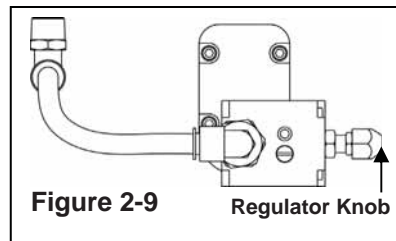

Figure 2-9

High Relieving Single Balance

Part Numbers: BCS2090, BCS2322

Installation

- Step 1. Unpack and inspect manifold, regulator and sensor assembly for damage. Remove tape on back of manifold that covers O-ring for shipping purposes. Check that the O-ring is seated into recess on back of manifold. If not, install provided O-ring.

NOTE

Air seal between the control module and balancer is required for proper operation.

- Step 2. Wipe the mounting surfaces with a damp cloth. Align the air outlet with the inlet on valve cap and attach control module to the valve cap with the four (4) provided bolts, torque to 5 ft lbs [6.8 nm].
- Step 3. Attach sensor assembly as listed below; refer to "Attaching the Load Hook" page 7.
- Cable- directly to the eye on the sensor
 - Chain- below the hook and above the load
 - Reeved- connect sensor to the pad eye on balancer and connect cable or chain to eye on the sensor.
- Step 4. Connect supplied hose to fitting on regulator and fitting on sensor.

Bench Setting

- Step 1. Deplete the relieving regulator by turning the knob counter-clock-wise until it stops. (See Figure 2-10)
- Step 2. Loosen set screw and turn knurled disk on sensor counter-clock-wise until spring tension is released.
- Step 3. Control module is now bench set. Additional adjustments (Refer to page 38) will be required after connecting main air (Refer to "Connecting Main Air" page 17).

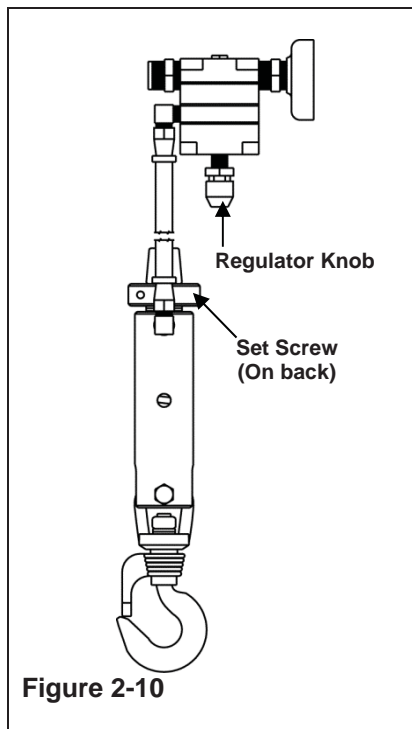

Figure 2-10

Feather Touch Control

Part Numbers: BCS2214, BCS2213

Installation

- Step 1. Unpack and inspect manifold, hoses and in-line valve assembly for damage.
- Step 2. Remove tape on back of manifold that covers O-ring for shipping purposes. Check that the O-ring is seated into recess on back of manifold. If not, install provided O-ring.

NOTE

Air seal between the control module and balancer is required for proper operation.

- Step 3. Wipe the mounting surfaces with a damp cloth. Align the air outlet with the inlet on valve cap and attach module to the valve cap with the four (4) provided bolts torque to 5 ft/lbs [6.8 nm].
- Step 4. Attach in-line valve assembly as listed below, refer to “Attaching the Load Hook” page 7.
 - Cable- directly to the eye on the in-line valve
 - Chain- below the hook and above the load
- Step 5. Connect yellow hose to the right side fitting (UP) on the manifold, connect opposite end to port 2 on the in-line valve.
- Step 6. Connect the black hose to left side fitting (DOWN) on the manifold, connect opposite end to port 4 on in-line valve.
- Step 7. Connect the white hose to the far right fitting on the manifold, connect the opposite end to port 1 on the in-line valve.

Bench Setting

- Step 1. Turn the drift adjustment screw (See Figure 2-11) counter-clock-wise until it stops and turn back one half turn.
- Step 2. Turn the flow control screw marked UP clock-wise until seated (do not over tighten) and back off one full turn.
- Step 3. Turn the flow control screw marked DN clock-wise until seated (do not over tighten) and back off one full turn.
- Step 4. Control module is now bench set. Additional adjustments (Refer to page 39) will be required after connecting main air (Refer to “Connecting Main Air” page 17).

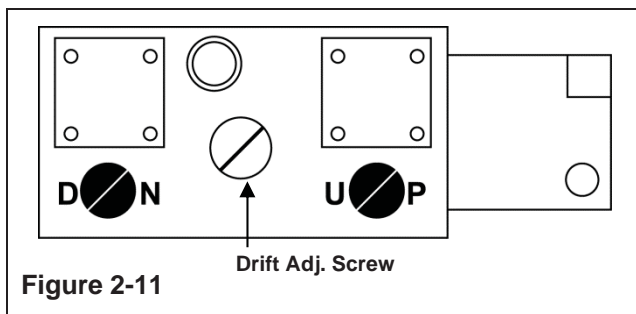

G. Trolley / Top Hanger Hook Installation

Rail Trolley

Part Numbers: Refer to the Knight website: http://www.knightglobal.com/balancer_acs.htm



Do not over-tighten nuts. Stress from over-tightening will cause damage to the can bracket.

- Step 1. Slide two (2) M16 x 2.0 x 100 mm HHCS with M16 washers through holes on one of the plates on the can bracket as shown below (See Figure 2-12).
- Step 2. Slide one (1) 5/8 x 1in.[25mm] spacer on each bolt and slide bolts through mounting holes on trolley.
- Step 3. Install two (2) remaining spacers, one (1) per bolt, between trolley and second plate on the can bracket as shown (See Figure 2-13).
- Step 4. Install two (2) M16 x 2.0 Nylok nuts and M16 flat washers onto mounting bolts. (See Figure 2-14)
- Step 5. Tighten Nylok nuts until snug and verify bolts do not rotate by hand, do not over tighten bolts.
- Step 6. Install safety cable; follow procedure on page 16.

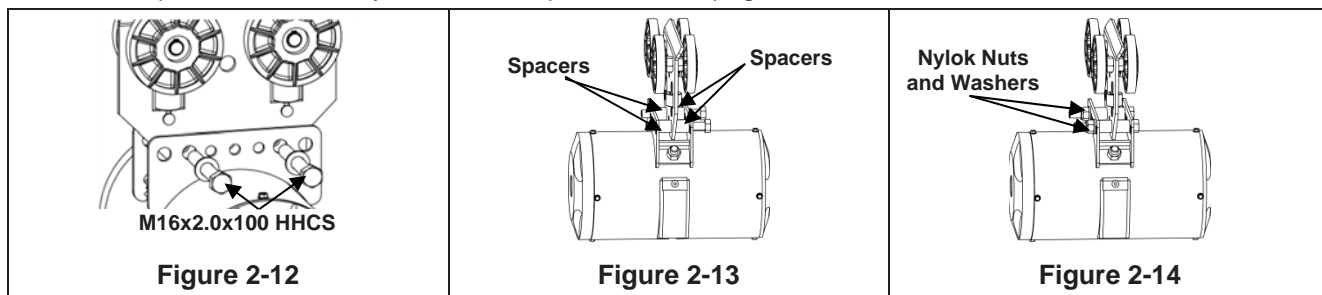

Top Hanger Hook

Part Number: BPA2016



Do not over-tighten nuts. Stress from over-tightening will cause damage to the can bracket.

- Step 1. Position the top hanger hook onto the can bracket off-set to the cable guide side. (See Figure 2-15)
- Step 2. Install the 1/2-13 x 4 in. HHCS bolt with two (2) 1/2 washers through the top hook assembly and the can bracket.
- Step 3. Install 1/2-13 rev lock nuts onto the bolt and tighten until snug, do not over tighten bolt.
- Step 4. Install second 1/2-13 rev lock nut onto bolt and tighten while holding first nut stationary.
- Step 5. Install safety cable; follow procedure on page 16.

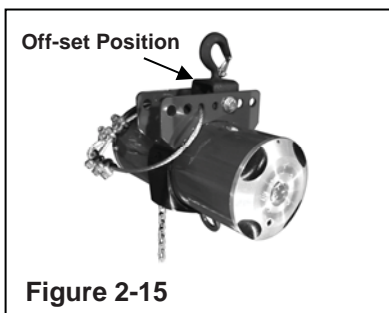

H. I-Beam Trolley

Part Number: Refer to the Knight website: http://www.knightglobal.com/balancer_acs.htm

The I-beam trolley is adjustable to fit different I-beam widths by placing an equal number of flat washers on both sides between the trolley plate and the can bracket (See Figure 2-16 below).

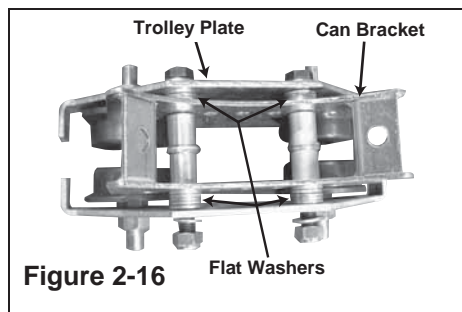

Figure 2-16



CAUTION!

Do not over-tighten nuts. Stress from over-tightening will cause damage to the can bracket.

- Step 1. Slide two bolts with washers into the bottom holes on the trolley plate. (See Figure 2-16)
- Step 2. Place required number of flat washers onto the bolts as shown below (See Figure 2-17).
- Step 3. Slide the bolts through the bolts holes in the can bracket so that the trolley plate will be centered on the can bracket.
- Step 4. Slide two (2) 1in.[25mm] spacers with two (2) washers between them onto each bolt (See Figure 2-18).
- Step 5. Slide the bolts through the second side of the can bracket.
- Step 6. Place the required flat washers onto each bolt.
- Step 7. Install the second trolley plate onto the bolts as shown below (See Figure 2-18).
- Step 8. Install two (2) M16 x 2.0 Nylok nuts and M16 flat washers onto mounting bolts.
- Step 9. Tighten Nylok nuts until snug and verify bolts do not rotate by hand, do not over tighten bolts.

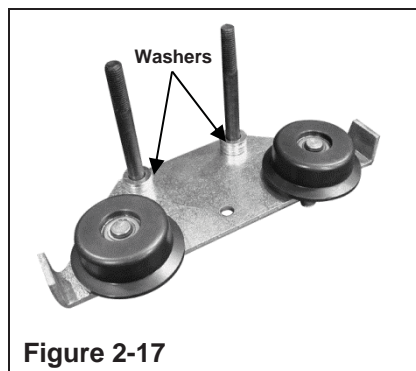

Figure 2-17

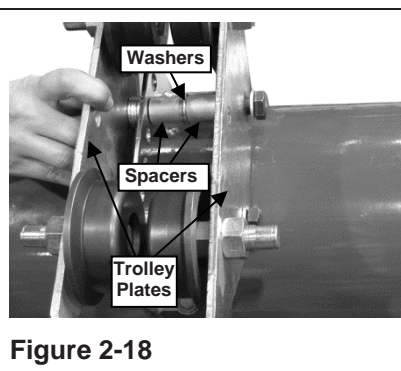

Figure 2-18

I. Safety Cable Installation

- Step 1. Slide thimbles together as shown (See Figure 2-19).
- Step 2. Slide two (2) cable clamps onto cable.
- Step 3. Loop end of cable around thimble and run end through cable clamps as shown (See Figure 2-19). The cable saddle (forged part) rests on the "live" (longer) end of the cable. The U-bolt rests on the "dead" (shorter) end of the cable.
- Step 4. Tighten nuts on clamps, alternating sides.
- Step 5. Follow the steps below for trolley or top hook.

Trolley

- Step 1. Insert cable through open hole on one side of the can bracket.
- Step 2. Insert cable through center hole on trolley.
- Step 3. Insert cable through hole on second side of the trolley plate.

Top Hook

- Step 1. Insert cable through both sides of the can bracket.
- Step 2. Loop the cable through the top hook.

- Step 6. Repeat steps 2 through 4 on other end of the cable. Install cable so that the balancer has a drop of not more than 1 in. [25mm].
- Step 7. Trim excess cable and tape ends of cable to prevent fraying.

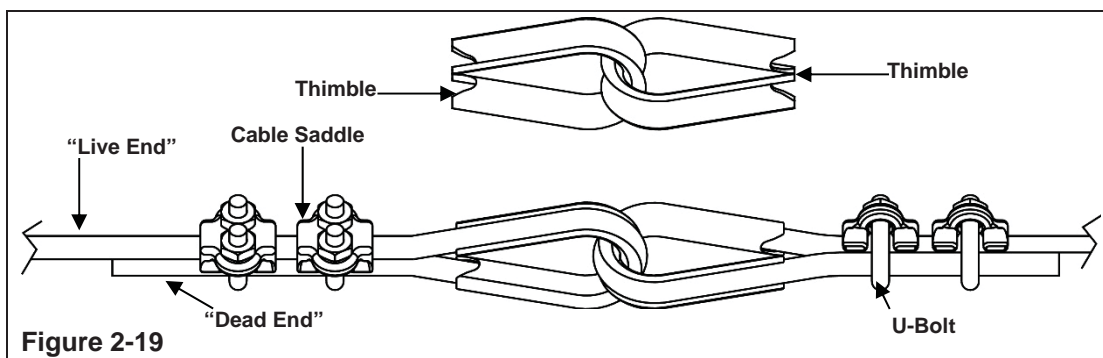

J. End of Travel Indicator Placement (Ball Stop)

This procedure must be completed after the pneumatic controls have been adjusted.

NOTE

End of Travel Indicator location is factory set. It must not be moved. Refer to pages 5 and 6 for Position and Height requirements.

- Step 1. Raise the cable or chain to the highest point in the stroke of the balancer.
- Step 2. Position the End of Travel Indicator on the cable or chain within 1 in. [25mm] of the cable guide. (See Figure 2-20 on page 17)
- Step 3. Tighten the End of Travel Indicator in place.
- Step 4. Cycle the balancer through the full range of stroke to check End of Travel Indicator position. The End of Travel Indicator should stop within 1 in. [25mm] of the cable or chain guide.

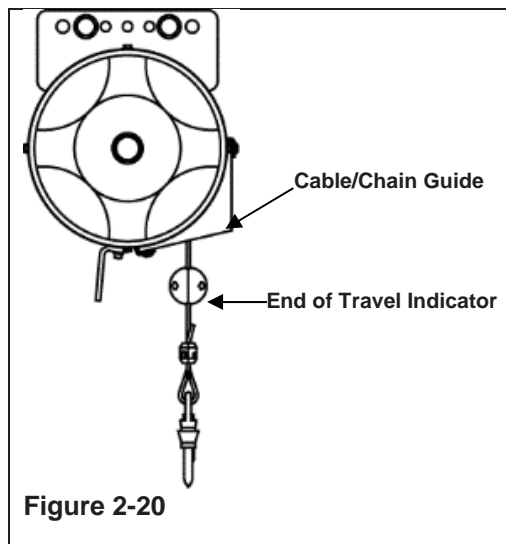

K. Connecting Main Air

The air supply is to be connected after the balancer is installed to the overhead structure and the supplied controls have been attached in accordance with the instructions in this manual.

Knight Global recommends at least 1/2 in.[12.7mm] I.D. hose to supply the balancer controls. Standard hose size is 1/2 in.[12.7mm] I.D. Adequate flow and pressure are also required. A minimum supply of 16 scfm at 100 psi [10.3 bar] or 10.4 scfm at 60 psi [4.1 bar], depending on the balancer model, is required for optimal balancer operation. Inadequate flow will cause sluggish performance.



CAUTION!

Do not exceed 150 psi [10.3 bar] inlet pressure.

- Step 1. Purge air lines and ensure they are free of all contaminants before connecting to the balancer.
- Step 2. Connect a clean, filtered, oil free air supply to the air inlet on the regulator or manifold.
- Step 3. Open air supply valves and/or lockout valves.
- Step 4. Set air regulator to at least 60 psi [4.1 bar].
- Step 5. Inspect system for loose fittings or leaks. Repair as necessary.
- Step 6. Follow operation adjustment procedures in the Maintenance Section of this manual to adjust the balancer for proper operation.



CAUTION!

The balancer will function after main air is supplied. Do not operate controls or make adjustments to regulator knobs without load attached to balancer.

3. OPERATION

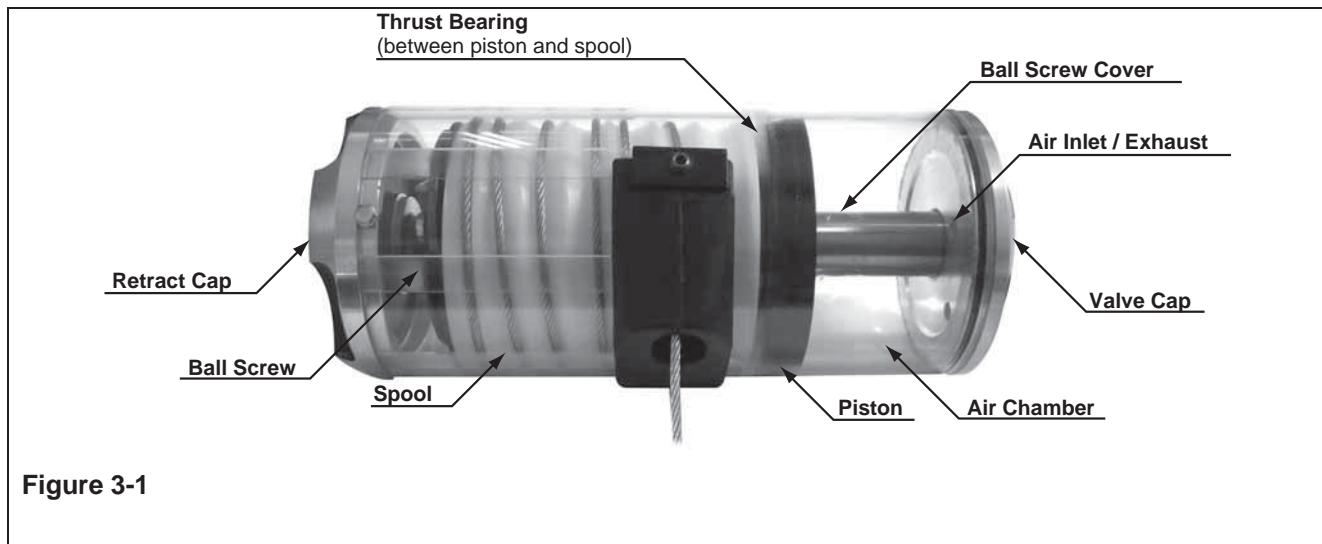

Figure 3-1

A. Principle of Operation

(See Figure 3-1)

Pressurized air enters the air chamber through the air inlet (regulated by a control module not shown). The air pressure pushes the piston into the thrust bearing. The thrust bearing transfers the force to the spool which rides on a stationary ball screw. The ball screw causes the spool to rotate taking in the cable or chain.

When air is exhausted from the air chamber, the weight of the load causes the spool to rotate in the opposite direction and the cable or chain is let out from the spool.

B. Model Number

The balancer model number designates the balancer type and specifications. The letters indicate the balancer type; refer to Table 1. The first set of numbers reference the rated balance capacity at 100 psi [6.89 bar] (KBA-100, KBA-150, KBC-100 and KBC-150 are rated at 110 psi [10.34 bar]) and the last set of numbers are the maximum stroke or travel of the balancer (See Figure 3-2). The letters "EX" after the model number designate that the balancer is fitted with an external retract device.

The model number and serial number can be found on the identification label located on the balancer can. (See Figure 4-16 on page 36 for label locations)

**For all models and specifications, refer to the website: <http://www.knightglobal.com/balancers.htm>.

Letters	Balancer Type
KBA	Single Cable
KBC	Single Chain
RKBA	Reeved Cable
RKBC	Reeved Chain
DKBA	Dual Drum Cable
DKBC	Dual Drum Chain
TKBA	Tandem Cable
TKBC	Tandem Chain
TRKBA	Tandem Reeved

Table 1

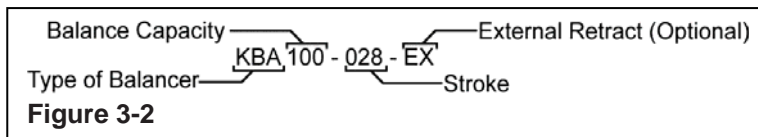

Figure 3-2

C. Balancer Sizing

Load Capacity

When specifying an air balancer, it is recommended to use 80% of the rated load to determine your load capacity. This approach compensates for the normal fluctuations within the plant compressed air supply. Balancers are rated at 100 psi therefore use the following example to calculate exact load capability.

Formula for Air Balancer sizing:

Example Balancing a Load:

Plant air 80 psi, 350 (Balancer rated capacity) x .80 (80PSI) [Pressure factor] = 280 lbs.

Example Lifting a Load:

Plant air 80 psi, 350 (Balancer rated capacity) x .80 (80 PSI) [Pressure factor] x .80 [lift factor] = 224 lbs.

Balancing a Load

Balancers are designed to float the weight, but can also be used as a hoist. Max load at 100 psi [6.89 bar] will balance a load but will not hoist the load. If 100 psi [6.89 bar] system pressure is not available, then the effort to move the load increases proportionally to the decrease in system pressure. The load should be 65 percent of the rated balancer capacity for optimal balance. Knight Global recommends the total load weight be 75 percent or less than the balancer capacity for hoist applications.

NOTE

Max load capacity at 100psi will balance the load, but not lift the load.

4. MAINTENANCE

A. Chain / Cable Inspection

4.1 INSPECTIONS

4.1.1 Chain / Cable Inspection Overview







The inspection procedures and recommendations in this manual are based on ANSI/ASME B30.16 and ISO7592-1983 "Calibrated Round Steel Link Lifting Chains –Guidelines to proper use and maintenance. The following definitions and recommendations are from both specifications and pertain to the recommended inspection procedures in this manual.

Qualified Person: a person who, by possession of a recognized degree in an applicable field, or certificate of professional standing, or who by extensive knowledge, training and experience, has successfully demonstrated the ability to solve or resolve problems relating to the subject matter at work.

Designated Person: a person selected or assigned by the employer or the employer's representative as being competent to perform specific duties.

Abnormal Operating Conditions: environmental conditions that are unfavorable, harmful, or detrimental to the operation of a hoist, such as excessively high or low ambient temperatures, exposure to weather, corrosive fumes, dust laden or moisture laden atmospheres, and hazardous locations.

4.2 Use of Chain/Cable Safely in Any Application

<p>Balance: Know the Load - determine the weight, center of gravity, angle and lift.</p>	
<p>Overload: Never Overload the Chain/Cable - check the working load limit on the identification tag.</p>	
<p>Knots, Twists and Kinks - Ensure chain/cable is not twisted, knotted or kinked before lifting load. Chains/cables should not be shortened with knots, bolts or other make-shift devices.</p>	
<p>Sharp Edges - Protect chain/cable with padding when lifting sharp edged loads.</p>	
<p>Abrupt Movement - Lift and lower loads smoothly. Do not jerk.</p>	
<p>Extreme Temperatures - Do not expose alloy chain to temperatures of 400°F or higher or -40°F or lower.</p>	

4.3 Determining the Frequency of Chain/Cable Inspections

Knight recommends utilizing load criteria and duty cycle data when determining the frequency of inspections. Inspection frequency should be identified by a qualified person and is based on factors such as severity of environment, percentage of capacity lifts, cycle time and shock loading. Each balancer should be rated individually and inspections performed in accordance with the rating.

Proper maintenance depends on an evaluation of the severity of usage to which the chain/cable and the application, in which it is installed, are subjected.

4.3.1 Service Rating Load Criteria

Light Service: Chains/cables and applications subjected very rarely to the maximum load and, normally, to light loads.

Moderate Service: Chains/cables and applications subjected fairly frequently to the maximum load and, normally, to moderate loads.

Heavy Service: Chains/cables and applications subjected frequently to the maximum load and, normally, to loads of heavy magnitude.

Very Heavy Service: Chains/cables and applications subjected regularly to the maximum load.

4.3.2 Service Class (Duty Cycle)

Service Class is determined by the specified fatigue life of the lifter.

- Service Class 0 is 0 to 20,000 load cycles. (Light Service)
- Service Class 1 is 20,001 to 100,000 load cycles. (Light Service)
- Service Class 2 is 100,001 to 500,000 load cycles. (Moderate Service)
- Service Class 3 is 500,001 to 2,000,000 load cycles. (Heavy Service)
- Service Class 4 is over 2,000,000 load cycles. (Very Heavy Service)

Cycles Per Day	Desired Life (Years)				
	1	5	10	20	30
5	0	0	0	1	1
10	0	0	1	1	2
25	0	1	1	2	2
50	0	1	2	2	3
100	1	2	2	3	3
200	1	2	3	3	4
300	2	3	3	4	4
750	2	3	4	4	4
1,000	2	3	4	4	4

4.4 Type of Inspections

Inspection procedure is divided into two general classifications based upon the intervals at which inspection should be performed for chains/cables in regular service. The general classifications are herein designated as "frequent" and "periodic" with respective intervals between inspection as defined below. (In addition, visual observations shall be conducted during regular service for any damage or evidence of malfunction which might occur between regular inspections.)

4.4.1 Frequent Inspection (Visual)

This is a visual examination by the operator or other designated personnel, without requiring records to be made. Inspection should be carried out at the following intervals:

- A. **Light Service** - Every Month
- B. **Moderate Service** - Every Two Weeks
- C. **Heavy Service** - Every Week
- D. **Very Heavy Service** - Every Day

Additionally, the operator should check the system continually during operation to ensure that no malfunctions are occurring (such as abnormal noises or binding).

4.4.1.1 Ideas Regarding What to Look for During A Frequent Inspection

Operator should examine the chain/cable throughout its working length to detect any evidence of wear, distortion or external damage. Equipment should be operated under a load as near as possible to the usual operating load, in both directions and observe the functioning of the chain/cable. The chain/cable should feed smoothly into and away from the balancer in each case. Additionally, the operator should check the system continually during operation to ensure that no malfunctions are occurring.

A. Chain

- Check for visual signs or abnormal noises (grinding etc.) which would indicate a potential problem.
- Ensure controls function properly and return to neutral when released.
- Check load chain feeds through the balancer spool and guides smoothly.
- If chain binds, is excessively noisy or "clicks"; clean and lubricate chain.

B. Cable

- Inspect the cable for damage such as kinking, bird caging, core protrusion, main strand displacement, corrosion, and broken or cut strands. If any damage is indicated do not operate the balancer until corrective actions are taken.
- Ensure controls function properly and return to neutral when released.
- Number, distribution, and type of broken wires. If any damage is indicated, do not operate the balancer until corrective actions are taken.
- The full extent of cable wear cannot be determined by visual inspection. At any indication of wear, the cable should be inspected following the criteria in "Periodic Inspection".

If any of the conditions listed above are evident, the Balancer should be placed out of service and a detailed inspection and corrective action should be taken.

4.4.2 Periodic Inspection (Documented)

This is a thorough examination by an appointed person, making records of external conditions to provide the basis for a continuing evaluation. Inspection should be carried out at least at the following intervals:

- A. **Light Service** - Yearly (equipment in place).
- B. **Moderate Service** – Every Six Months (equipment in place unless external conditions indicate that disassembly should be done to permit detailed inspection).
- C. **Heavy Service** – Every Three Months (equipment in place unless external conditions indicate the disassembly should be done to permit detailed inspection).
- D. **Very Heavy Service** — Every Six Weeks (equipment in place unless external conditions indicate that disassembly should be done to permit detailed inspection).

4.4.2.1 Recommendations for Periodic Inspections of Chain (KBC)

Chains should be cleaned for inspection, using any cleaning method that will not cause damage. Adequate lighting should be provided for the person inspecting the chain. The chain should be examined link by link for cracks, gouges or nicks, distortion, corrosion, deposits of foreign material and for interlink wear. To inspect for wear at the interlink contact points, slacken the chain and rotate adjacent links to expose the inner ends of the link. If wear is observed or if elongation is suspected, measure the chain using the Knight Global chain gauge (purchased separately) or by using a caliper type gauge.

A. Chain Link Thickness

If chain is worn to less than the minimum allowable thickness (T), remove the chain from service.



Figure 4- 1

Minimum Allowable Chain Link Thickness at Any Point

Nominal Chain Size		Minimum Thickness "T"	
Inches	mm	Inches	mm
.157	4.0	.137	3.48
.196	5.0	.171	4.35

B. Chain Gauge Replacement Measurement for 4mm and 5mm Load Chains

Contact local Knight Global Representative or call 248-377-4950 to purchase chain gauge (Part# KSAA1003).

1. Determine which type of chain is being inspected, either 4mm or 5mm (balancer chain is 5mm only), by placing a single link into the chain gauge where the arrows are located. (See Figure below).
2. Raise the balancer to the full up position and mark the chain.
3. Lower the balancer to the full down position.
4. Select 13 links starting with the link that was marked in step 2.
5. The 13 selected links will fit loosely onto gauge prongs as shown below. If links number 1 and 13 do not fit onto prongs or have to be forced into selection, replace the load chain. This length has stretched 2% or more and should be removed from service and replaced with new chain.
6. Perform this inspection in multiple sections of the chain working up to the balancer chain guide.

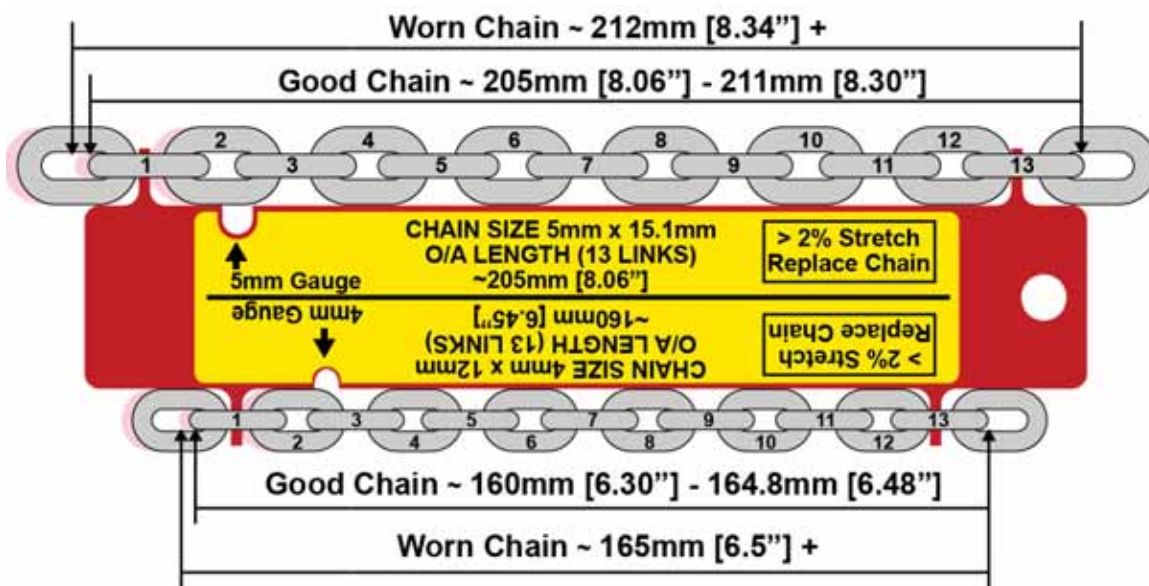

Figure 4- 2

C. If Chain Gauge is Not Available

- Select an unworn, unstretched length of chain.
- Suspend the chain vertically under tension. Use a caliper type gauge to measure the accumulated pitch of between 5 and 13 links.
- Measure the same number of links throughout the used chain and calculate the percentage increase in length.
- The chain should be replaced if the gauge length measured over any 5, 7, 9, 11, or 13 links as appropriate exceeds that of the unused chain by 2 % if power driven.

D. Rejection Criteria for Chain

The chain should be rejected if any of the following conditions are observed:

- Cracked or worn links
- Severe nicks or gouges
- Twisted or bent links
- Corrosion
- Deposits which cannot be removed
- Increase in gauge length which exceeds the manufacturer's recommendations. In the absence of manufacturer's recommendations the chain should be replaced if the gauge length measured over any 5, 7, 9, 11, or 13 links as appropriate exceeds that of the unused chain by 2 % if power driven.

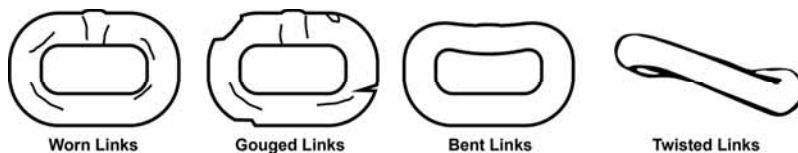

Figure 4- 3

4.4.2.2 Recommendations for Periodic Inspections of Cable (KBA)

Cable should be cleaned for inspection, using any cleaning method that will not cause damage. Adequate lighting should be provided for the person inspecting the cable. The inspection shall cover the entire length of the cable. The individual outer wires in the strands of the cable shall be visible to the person during the inspection.

A. Cable Thickness:

Measure the cable from crown to crown (See Figure below). This should be done each time under the same load and in the same location to ensure accurate measurements throughout the life of the cable. Diameter of cable is 3/16 in.[4.7mm].

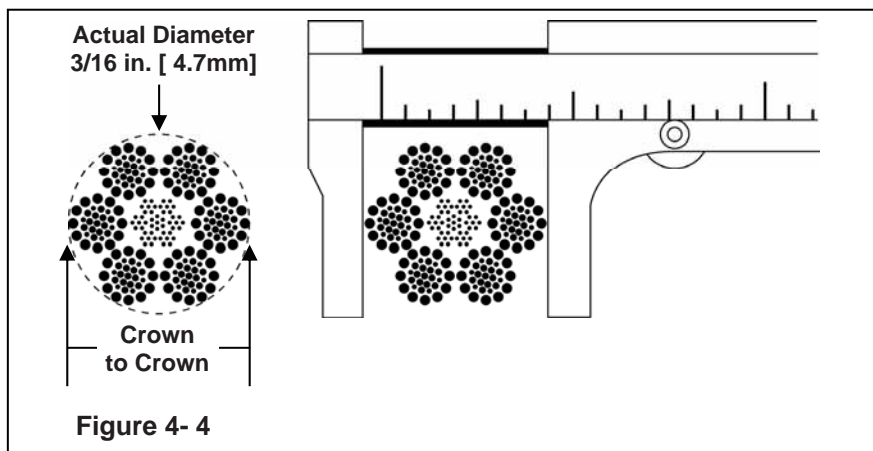
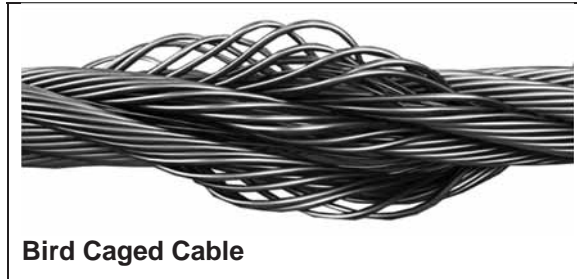

Figure 4- 4

B. Rejection Criteria for Cable

The cable should be rejected if any of the following conditions are observed:

- Excessive build-up of dirt.
- Twisted or bird caged wires.
- Corrosion.
- Deposits which cannot be removed.
- New cable has a diameter of 3/16 in. [4.7mm]. Decrease in cable diameter of more than .015 in. [0.4mm]. or if cable diameter is .1725 in. [4.3mm] or less, replace cable.

**4.4.2.3 Recommended Record Keeping for Periodic Inspections**

Adequate records as a part of periodic inspection are essential for the proper use of calibrated chains/cable.

The chain/cable record should include a complete description and identification of the new chain/cable, the date and results of each inspection, the date and results of each test and the date and description of any maintenance.

The record is a continuous history of the chain/cable and shows that it has been regularly inspected and maintained in good operating condition.

When the chain/cable is removed from service, a new record should be prepared for the replacement chain/cable.

4.4.3 Chain/Cable Lubrication:

Keep chain/cable well lubricated. Never operate a balancer when the load chain/cable does not flow freely and smoothly into and out of the balancer, or when it makes noises indicative of binding or other malfunctions. If the chain/cable is visibly damaged, replace the chain/cable and examine the spool and chain/cable guard. Install a new guard if the old one is broken or distorted.

Clean, lubricate, and inspect load chain/cable based on frequent inspection criteria described in section 4.4.1. In a corrosive environment, lubricate more frequently than normal. Failure to maintain clean and well lubricated load chain/cable will result in rapid wear that can lead to chain/cable failure which can cause severe injury, death or substantial property damage.

If required, clean chain/cable with acid free solvent to remove rust or abrasive dust buildup and lubricate chain/cable.

CHAIN:

Lubricate chain without load on chain. This will allow lube to penetrate between links. Lubricate each link of the chain with a light coat of SAE 50 to 90 EP oil or equivalent machine/gear oil. Ensure that oil is applied to the bearing surfaces of the load chain links. Wipe off excess oil from the load chain surfaces.

CABLE:

Lubricate entire length of cable with a penetrating lubricant. Knight recommends the use of a high performance, extreme pressure, anti-wear food grade penetrating oil that penetrates and lubricates cable and all types of moving parts (ie. Lubriplate® 1241). Those sections of cable that are located over sheaves or otherwise hidden during inspection require special attention when lubricating the cable. The objective of lubricating the cable is to reduce internal friction and to prevent corrosion.

Substitute a dry lubricant for use in dusty environments.

Lubricate hook and safety latch pivot points with same lubricant used on the load chain/cable.

Failure to maintain clean and lubricated load chain will void the manufacturer's warranty.

4.5 Cable Replacement

The cable can be replaced at a work bench or with the balancer in the installed location.

- Step 1. Completely exhaust air from the balancer to fully extend cable out of balancer and remove load from hook.
- Step 2. Shut off air supply or engage lock out if installed.
- Step 3. Make provisions to prevent movement of trolley if balancer is trolley mounted.
- Step 4. Measure and record distance from hook throat to cable guide opening.
- Step 5. Remove barrel clamp and load hook from cable.
- Step 6. Remove the End of Travel Indicator.
- Step 7. Remove cable guide clamp(s) and cable guide. (See Figure 4-5)

NOTE

The ball shank should now be visible through the cable guide hole. Spool repositioning may be necessary to find the ball shank.

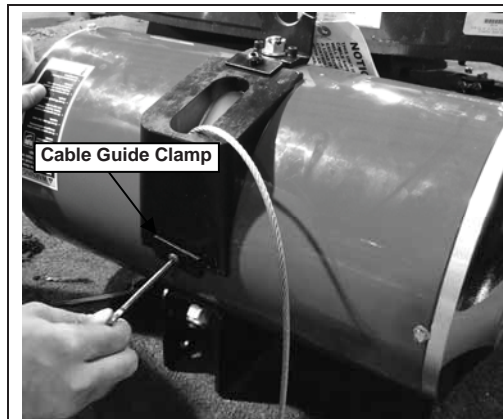

Figure 4-5

- Step 8. Remove 1/4-20 x 1/2 SHCS located above the ball shank from the balancer spool. (See Figure 4-6)

NOTE

Balancers manufactured prior to July 2003 will not have the 1/4-20 x 1/2 SHCS installed in the balancer spool.

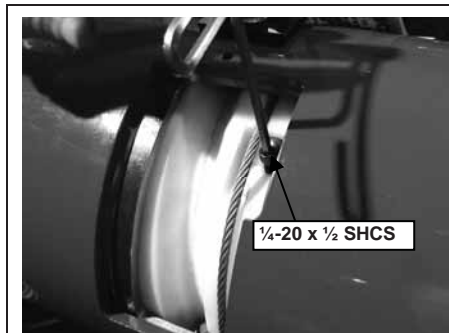

Figure 4-6

Step 9. Remove the ball shank from the ball shank seat.

NOTE

The ball shank may need to be tapped out of the ball shank seat.
(See Figure 4-7)

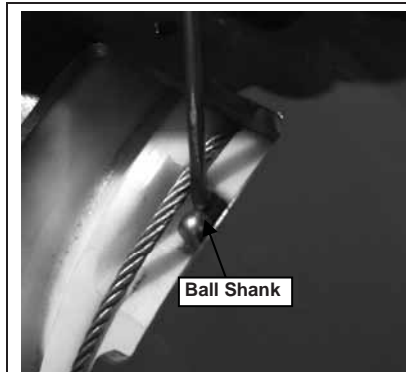

Figure 4-7

Step 10. Push the cable around the spool and remove the cable completely from the spool.

NOTE

If cable end is frayed, cleanly cut cable above frayed end. Cable may be cut near cable guide opening on balancer.

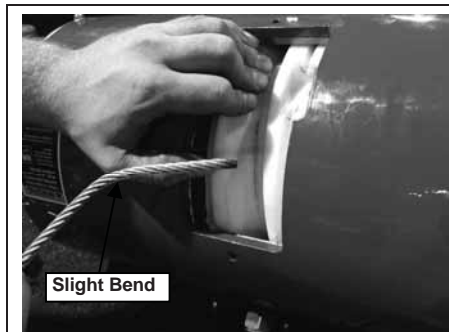

Figure 4-8

Step 11. Put a slight bend in the fused end of the new cable. (See Figure 4-8)

Step 12. Feed the cable through the ball shank seat until it comes out the other side of the spool.
(See Figure 4-9)

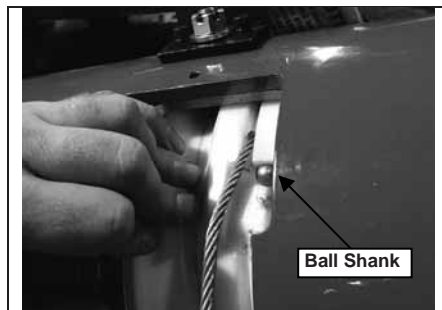

Figure 4-9

- Step 13. Pull cable completely through the balancer.
- Step 14. Insert the cable into the next groove in the spool and push the cable until it comes out the other side of the spool. Correctly installed cable will be centered in the cable guide opening.
- Step 15. Ensure that the ball shank is seated in the ball shank seat in the balancer spool.

NOTE

If the ball shank does not seat, sharply tug on the cable to seat the ball shank in the spool and tap to fully seat.

- Step 16. Reinstall 1/4-20 x 1/2 SHCS (if removed) into the balancer spool above the ball shank. (See Figure 4-10)

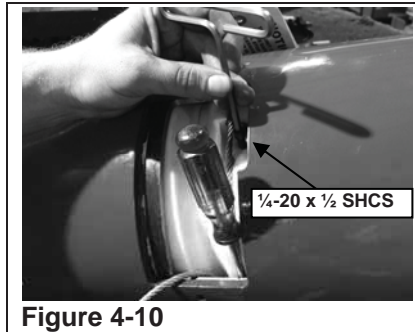

- Step 17. Reinstall cable guide and cable guide clamp(s).
- Step 18. Slide the End of Travel Indicator onto the cable, do not tighten.
- Step 19. Using dimension from step 4, reinstall hook on cable with barrel clamp and thimble. Refer to "Attaching the Load Hook" page 7.
- Step 20. Reattach load and turn air supply on.
- Step 21. Check system for proper operation and retighten fasteners after initial loading.
- Step 22. Position the End of Travel Indicator; refer to "End of Travel Indicator Placement" procedure on page 16.

4.6 Chain Replacement

- Step 1. Completely exhaust air from balancer to fully extend chain out of balancer and remove load from hook.
- Step 2. Shut off air supply or engage lock out if installed.
- Step 3. If balancer is trolley mounted, provisions should be taken to prevent movement of the trolley.
- Step 4. Measure distance from the center line of the cross-bolt on swivel shackle to chain guide opening and record distance.
- Step 5. Place swivel shackle sleeve on flat surface with pin flats facing up (pin can only be driven out of sleeve in one direction). Use a hammer and drift punch to drive pin out of sleeve.
- Step 6. Remove the End of Travel Indicator (ball stop).
- Step 7. Remove chain guide clamp(s) and chain guide. (See Figure 4-11)

NOTE

The end link bolt should be visible through the chain guide hole. Spool repositioning may be necessary to find the end link bolt. If the end link bolt is not visible, contact the Knight Global Balancer department for further instructions.



Figure 4-11

- Step 8. Remove the end link bolt and washer from the spool and chain. (See Figure 4-12)
- Step 9. Pry the links from the spool chain seat and pull the chain out of the balancer.

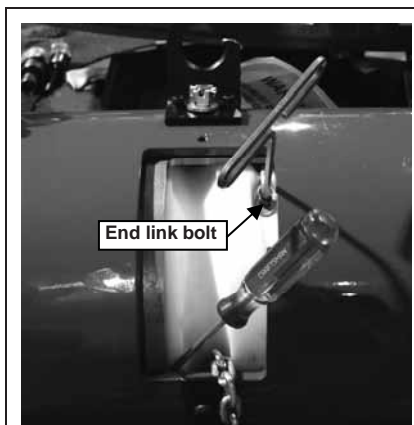

Figure 4-12

- Step 10. Connect a stiff wire to the last chain link on new chain and thread the wire around the top of the second to last groove from the left and pull the chain around the spool. (See Figure 4-13 and Figure 4-14)

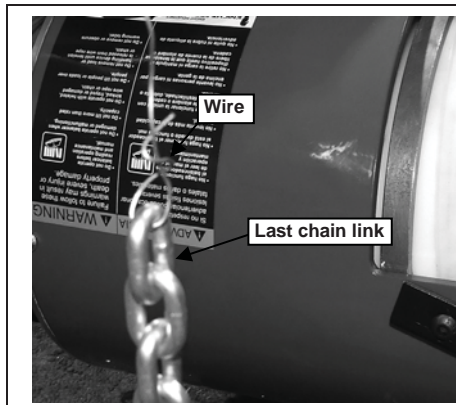

Figure 4-13

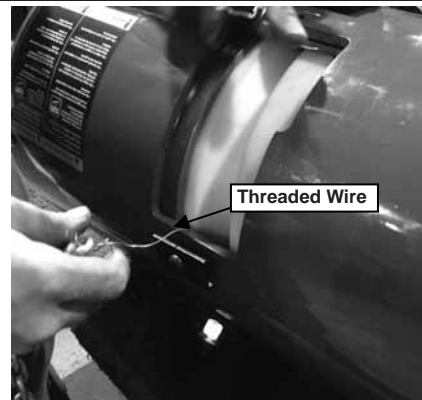

Figure 4-14

- Step 11. Reinsert the wire into the last groove on the left and pull the chain through.
 Step 12. Remove the wire from the chain and tap the chain into the spool chain seat. (See Figure 4-15)



Figure 4-15

- Step 13. Reinstall 1/4-20 end link bolt and washer into the chain and spool and tighten until snug. (See Figure 4-12)

NOTE

Slight widening of the end chain link to accommodate the end link bolt grip is acceptable.

- Step 14. Reinstall chain guide and chain guide clamp(s).
 Step 15. Using dimension from Step 4, cut chain at length to match previous install height.
 Step 16. Place sleeve on flat surface, align pin flat with chain link in chain nest and drive pin through chain until flush with sleeve (refer to "Attaching the Swivel Shackle" page 8).
 Step 17. Reattach load and turn main air supply on.
 Step 18. Check system for correct operation.
 Step 19. Position the End of Travel Indicator; refer to "End of Travel Indicator Placement" procedure on page 16.

B. PREVENTATIVE MAINTENANCE FOR KNIGHT BALANCERS

4.7 Balancer Inspections

4.7.1 Recommendations for Frequent Inspections for Balancers (Visual)

This is a visual examination by the operator or other designated personnel, without requiring records to be made. Inspection should be carried out at the following intervals recommended in section 4.4.1 page 23.

Additionally, the operator should check the system continually during operation to ensure that no malfunctions are occurring.

4.7.1.1 Balancer:

- Visually inspect the balancer, ensure that it is in good general working order. Repair or replace any broken or missing parts.
- Cycle the balancer and listen for any abnormal noises (grinding etc.). If any abnormal noises are evident, a periodic inspection of the balancer must be performed.
- Binding of the cable or chain. Check to ensure that the hook swivel is moving freely and not binding.

4.7.1.2 Reeving Block (if applicable):

- Ensure there is no twisting or kinking.
- Check that cable or chain spools evenly and correctly into grooves.
- Ensure all fasteners are properly tightened.

4.7.1.3 Controls (if applicable):

- Verify balancer response to the pendant is quick and smooth.
- Ensure the controls return to neutral when released.

4.5.1.4 Air System:

- Inspect the system for air leaks. Repair any leaks that are found.
- Check the filter to ensure that it is clean. Replace the filter if required.

If any of the conditions listed above are evident, the Balancer should be placed out of service and a detailed inspection and corrective action should be taken.

4.7.2 Periodic Inspection (Documented)

Perform the items listed in the Frequent Inspection section 4.7.1 in addition to the items listed below. All findings from this inspection should be recorded.

4.7.2.1 Supporting Structure:

- Check for distortion, wear and continued ability to support the load. Refer to manufacturers' instructions for overhead rail systems.

4.7.2.2 Top Mount Single Hook Hanger (if applicable):

- Check all fasteners; ensure they are intact and properly tightened.
- Check hook for wear, damage, twisting or bending.
- Ensure safety latch contacts the hook tip.

4.7.2.3 Rail Trolley (if applicable):

- Ensure wheels and side rollers run smoothly and are not excessively worn. Replace the wheels and side rollers as necessary.
- Check all fasteners, ensure they are intact and properly tightened.
- Visually check the nylon at the bearing and along the face of the wheel for cracks.

4.7.2.4 I-Beam Trolley (if applicable):

- Ensure wheels run smoothly and are not excessively worn. Replace as necessary.
- Ensure the wheels track the beam properly.
- Check the side plates for spreading. Repair or replace the trolley as required.

4.7.2.5 Balancer:

- Cycle balancer to inspect the ball screw bearing for wear. Any binding, noise or hesitation may indicate wear beyond recommended limits. Inspections should be more frequent to monitor existing defects not repaired.
- Inspect balancer end caps for leakage and security.
- Remove cable guide clamp(s) and slide cable guide until spool is visible.
- Inspect spool for signs of wear at the root diameter.
- Inspect balancer liner for security. If liner movement is evident take balancer out of service.
- For cable balancers check cable termination for security. Cable ball shank should be seated securely in ball shank seat.
- For chain balancers, check chain termination for security. Verify torque of link secure bolt.
- Reinstall cable guide and cable guide clamp(s).

4.7.2.6 Fasteners:

- Check all fasteners for security.
- Check balancer bracket mounting fasteners for security. If wear is evident or if bracket is not secure, remove balancer from service.

4.7.2.7 Load Hook (if applicable):

- Open latch and inspect for cracks, wear or damage.
- Inspect hook throat for spreading and proper safety latch engagement.
- Measure hook throat at wear points. See manufacturer's instructions for wear zone information.
- Ensure hook eye is intact and secure.
- Inspect hook eye for free rotation without binding.

4.7.2.8 Swivel Shackle (if applicable):

- Inspect chain nest and sleeve, ensure they are intact and secure.
- Inspect the shackle for free rotation without binding.
- Inspect shackle for spreading, misalignment, cracks, wear or damage.
- Inspect cross-bolt for free rotation, wear or damage.

4.7.2.9 Labels and Tags:

- Ensure that all labels are intact and legible (See Figure 4-16). Replace as necessary.

4.7.2.10 Balancers Not In Regular Use:

- Idle for more than one month, but less than one year, perform the daily inspection on the balancer before placing it into service.
- Idle for more than one year; perform the detailed inspection before placing the balancer into service.
- Stand-by balancers should have the daily inspection performed at regular intervals as conditions require.

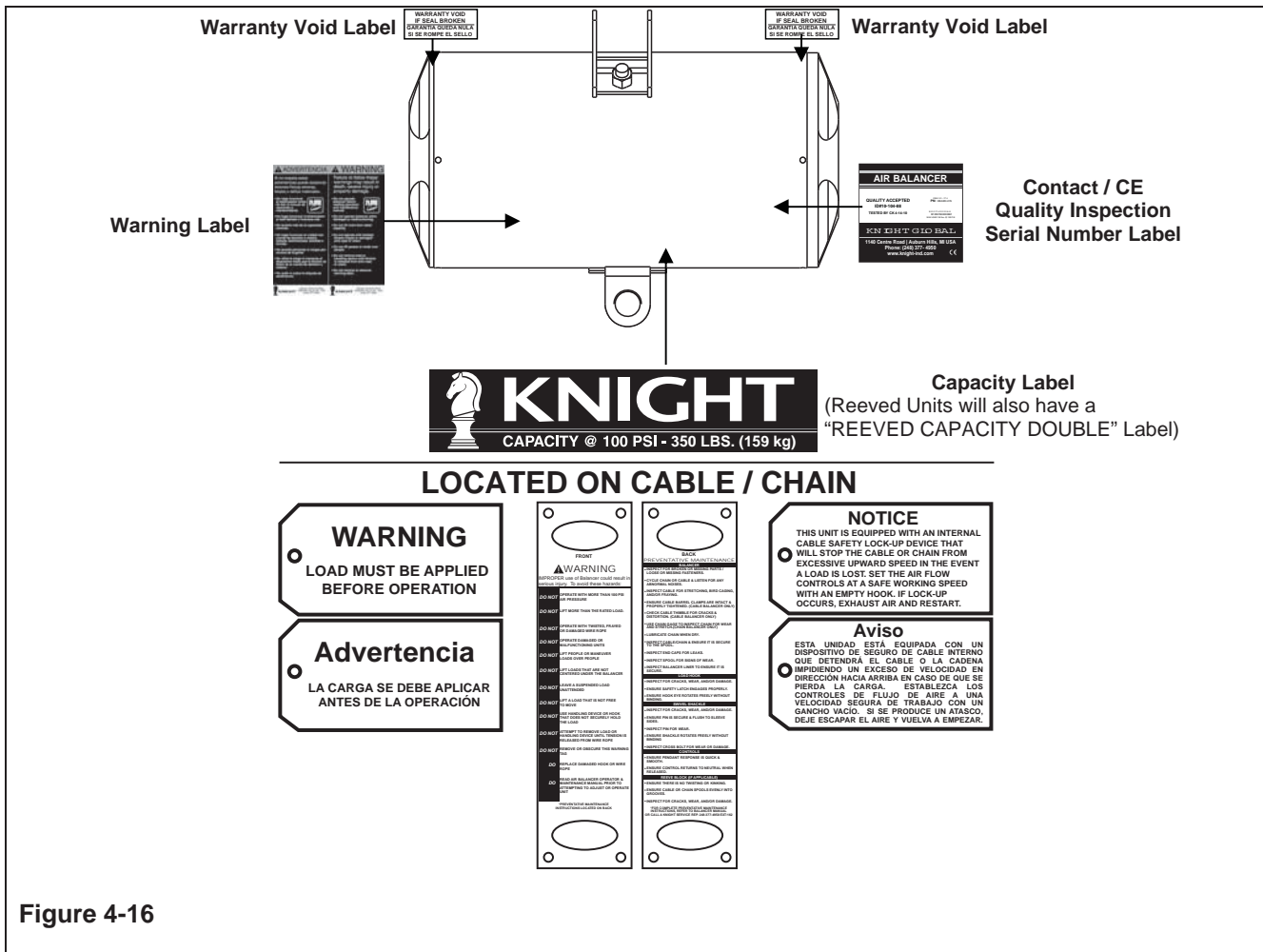

Figure 4-16

C. Adjustments

4.8 Operation Adjustments

4.8.1 Pendant Control

Part Numbers: BCS3017, BCS3320, BCS3330, BCS2326, BCS2231, BCS2327, BCS2091, BCS2321



The balancer will function after main air is supplied. Do not operate controls or make adjustments to regulator knobs without load attached to balancer.

- Step 1. Attach load (fixture with part) to the load hook.
- Step 2. Lightly press the UP button to raise the load.
- Step 3. If the load does not raise or is slow, turn the UP flow control counter-clockwise while pressing the UP button until desired speed is met. If the balancer is still slow or does not move turn the DN flow control clockwise until the desired up speed is obtained.

NOTE

If faster upward travel is required, system pressure and/or flow must be increased. It may be necessary change to a larger capacity balancer.

- Step 4. Depress the DOWN lever to lower the load.
- Step 5. Increase the speed by turning the DN flow control counter-clockwise until desired speed is met.

NOTE

If after adjustments are made and the load still does not move, see "Resetting the Internal Safety Retract Control" on page 40.

NOTE

Downward travel is determined by the force of gravity on the load. Lighter loads may require assistance for rapid downward travel.

4.8.2 Dual Balance

Part Numbers: BCS2215, BCS2323



The balancer will function after main air is supplied. Do not operate controls or make adjustments to regulator knobs without load attached to balancer.



Pneumatic circuits using dual balance modules require additional safety logic to prevent unintentional cable acceleration.

- Step 1. Attach the fixture (no part) to the load hook.

- Step 2. Press the lever on the right side of the pendant or send an air signal to the right side fitting on the dual balance control module. (continued on next page)
- Step 3. Slowly turn the left hand relieving regulator knob (furthest from the air supply) clock-wise until the load begins to rise.
- Step 4. While the load is rising slowly, turn the relieving regulator adjustment knob counter-clock-wise until the load stops rising.
- Step 5. Adjust the knob until the effort to move the load up and down is equal.
- Step 6. Load the part into the fixture.
- Step 7. Press the lever on the left side of the pendant or send an air signal to the left side fitting on the dual balance control module.
- Step 8. Slowly turn the right hand regulator knob until the load begins to rise.
- Step 9. While the load is rising slowly, turn the relieving regulator adjustment knob counter-clock-wise until the load stops rising.
- Step 10. Adjust the knob until the effort to move the load up and down is equal.

4.8.3 Single Balance

Part Number: BCS2018



CAUTION!

The balancer will function after main air is supplied. Do not operate controls or make adjustments to regulator knobs without load attached to balancer.

- Step 1. Attach load to the load hook.
- Step 2. Slowly turn the relieving regulator knob clock-wise until the load begins to rise.
- Step 3. While the load is rising slowly turn the relieving regulator adjustment knob counter-clock-wise until the load stops rising.
- Step 4. Adjust the knob until the effort to move the load up and down is equal or until desired effect is achieved.

4.8.4 High Relieving Single Balance

Part Number: BCS2322, BCS2090



CAUTION!

The balancer will function after main air is supplied. Do not operate controls or make adjustments to regulator knobs without load attached to balancer.

- Step 1. Attach load to the load hook.
- Step 2. Slowly turn the adjustment knob on the regulator clock-wise until the load begins to rise or the adjustment knob stops. Back the adjustment knob off one and a half full turns. The cable or chain may become taut, but the load might not rise.
- Step 3. On the sensor, turn the knurled disk clock-wise until the load begins to rise.
- Step 4. While the load is rising, slowly turn the sensor knurled disk counter-clock-wise until the load stops rising.
- Step 5. When correctly set, the sensor will leak a small amount of air.

- Step 6. Adjust the sensor knurled disk until the effort to move the load up and down is equal or until desired effect is achieved.
- Step 7. Tighten the set screw on the sensor knurled disk to lock in place.

4.8.5 Feather Touch Control

Part Number: BCS2214, BCS2213



The balancer will function after main air is supplied. Do not operate controls or make adjustments to regulator knobs without load attached to balancer.

- Step 1. Attach load (fixture with part) to the load hook.
- Step 2. Slide the feather touch control handle upward to raise the load.
- Step 3. If the load does not rise, or is slow, turn the UP flow control counter-clock-wise while pressing up on the control handle. If the load does not move, or is still slow, turn the DN flow control counter-clock-wise until desired up speed is obtained.

NOTE

If faster upward travel is required, system pressure and/or flow must be increased. It may be necessary to change to a larger capacity balancer.

- Step 4. Grasp the feather touch control handle and slide downward to lower the load.
- Step 5. Turn the DN flow control counter-clock-wise to increase the speed until desired speed is met.

NOTE

Downward travel is determined by the force of gravity on the load. Lighter loads may require assistance for rapid downward travel.

4.8.6 Drift Adjustment

Part Number: BCS3017, BCS3320, BCS3330, BCS2326, BCS2214, BCS2213, BCS2231, BCS2327, BCS2091, BCS2321

- Step 1. Position the load in the center of travel.

NOTE

Some applications may experience load drift up or down after idle periods.

- Step 2. Ensure that the load does not move upward or downward without the control levers being pressed.
- Step 3. Adjust the drift adjustment on the control module to eliminate drift:
 - Downward Drift- Turn clock-wise
 - Upward Drift- Turn counter-clock-wise

NOTE

If turning the drift adjustment clock-wise three or four full turns does not eliminate downward drift, check the pneumatic circuit for leaks.

D. Internal Retract Control

4.9 Resetting Internal Retract Control

NOTE

Applying air to an unloaded balancer and/or not bench setting control modules will result in retract control engagement. Ensure load is attached to balancer prior to airing up. Failure to do so will result in activating the internal retract control. Consequently, the balancer will lock-up.

4.9.1 Pendant Control

Part Numbers: BCS3017, BCS3320, BCS3330, BCS2326, BCS2231, BCS2327, BCS2091, BCS2321

- Step 1. Press the DOWN button to deplete pressure in balancer; if the load lowers, the internal retract control has reset. If the load does not lower, proceed to step 2.
- Step 2. Pull down sharply on the cable or chain. (See Figure 4-17) If the load still does not lower, proceed to step 3.
- Step 3. Ensure balancer is at full extension of travel, apply an additional 30 lbs. of weight to the load, manually lift the load a few inches, and let the load fall. Ensure that all personnel are a safe distance away from the load. This action compresses the piston; which will reset the internal retract control. If the internal retract control still does not reset, contact the Knight Global Balancer department for further instructions.

4.9.2 Single Balance / Dual Balance

Part Numbers: BCS2018, BCS2322, BCS2215, BCS2323, BCS2090

- Step 4. Turn adjustment knobs on relieving regulators fully counter-clock-wise; if the load lowers, than the internal retract control has reset. If the load does not lower, proceed to step 2.
- Step 5. Pull down sharply on the cable or chain. (See Figure 4-17) If the load still does not lower, proceed to step 3.
- Step 6. Ensure balancer is at full extension of travel, apply an additional 30 lbs. of weight to the load, manually lift the load a few inches, and let the load fall. Ensure that all personnel are a safe distance away from the load. This action compresses the piston; which will reset the internal retract control. If the internal retract control still does not reset, contact the Knight Global Balancer department for further instructions.

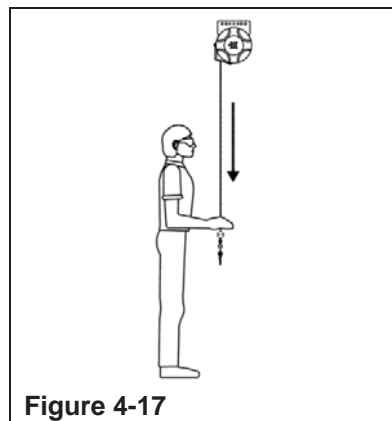

Figure 4-17

5. TROUBLESHOOTING

Balancer operation may be affected by various factors. If your balancer is not performing as well as expected, contact the Knight Service Department at 248-377-4950 ext. 162 or via e-mail at service@knightglobal.com. A Troubleshooting chart can be found on the Knight website @:
http://www.knightglobal.com/brochures/knight_balancer_troubleshooting_guide.pdf.

6. SPARE PARTS LIST

Because Knight is continuously improving and updating its products, all product drawings and spare parts lists for the balancers can be found on the Knight website @ <http://www.knightglobal.com/balancers.html>.

7. DECOMMISSIONING OF AN AIR BALANCER

Knight Air Balancers contain various materials which, at the end of the service life, must be disposed of or recycled (where appropriate), in accordance with statutory regulations.

Decommissioning:



Knights Air Balancers must only be decommissioned by qualified personnel.

- Ensure there is not a load on the balancer.
- Depressurize air line(s).
- Detach the control hose(s) from the balancer.
- Remove any safety cabling. (Reverse steps in Installation section for Safety Cable on page 16)
- Remove / dismount balancer from structure. (Reverse steps in Installation section for Trolleys and Top Hook on pages 14 and 15)

8. KNIGHT'S PERFORMANCE WARRANTY

Knight warrants that its products and parts shall meet all applicable specifications, performance requirements, and be free from defects in material and workmanship for one year, (Servo Systems for (2) two years, Pneumatic Lift Tables for (5) five years), from the date of invoice, unless otherwise noted.

Knight warrants the Servo Hoist, Arms, and Tractors to be free from defects in material or workmanship for a period of two years or 6000 hours use from the date of shipment.

On design and build jobs, the customer is the owner of the equipment once they authorize shipment. The purchased equipment cannot be returned for reimbursement or credit.

Exclusions

This warranty shall not cover the failure or defective operation caused by inadequate training provided by customer regarding the operation and/ or maintenance of the tool, misuse, negligence, misadjustment, or any alteration not approved by Knight Global. Knight's obligation is limited to the replacement or repair of Knight's products at a location designated by Knight Global. Buyer is responsible for all associated internal removal and reinstallation costs as well as freight charges to and from Knight Global. Knight's maximum liability shall not in any case exceed the contract price for the products claimed to be defective.

Any field modification made to Knight Products or Systems without the written authorization by Knight Global shall void Knight's warranty obligation.

Any purchased components not manufactured by Knight Global and their specific individual warranties are not covered. Paint defects, scratches and marring from shipping are also excluded on all Knight Global products and products not manufactured by Knight Global.

Knight Distributors/ Agents are not authorized to circumvent or change any of these terms and/ or conditions of this warranty unless prior approval is received in writing by Knight Global Management. Verbal statements made by Knight Distributors/ Agents do not constitute warranties.

Disclaimer

OTHER THAN AS SET FORTH HEREIN, NO OTHER EXPRESSED WARRANTIES, AND NO IMPLIED WARRANTIES, ORAL AND WRITTEN, INCLUDING BUT NOT LIMITED TO THE WARRANTIES OF MERCHANTABILITY OR FITNESS FOR A PARTICULAR PURPOSE, ARE MADE BY KNIGHT GLOBAL WITH RESPECT TO ITS PRODUCTS AND ALL SUCH WARRANTIES ARE HEREBY SPECIFICALLY DISCLAIMED.

KNIGHT GLOBAL SHALL NOT BE LIABLE UNDER ANY CIRCUMSTANCES FOR ANY INCIDENTAL, SPECIAL AND/OR CONSEQUENTIAL DAMAGES WHATSOEVER, WHETHER OR NOT FORESEEABLE, INCLUDING BUT NOT LIMITED TO DAMAGES FOR LOST PROFITS AND ALL SUCH INCIDENTAL, SPECIAL AND/OR CONSEQUENTIAL DAMAGES ARE HEREBY ALSO SPECIFICALLY DISCLAIMED.

KNIGHT GLOBAL WILL NOT BE LIABLE FOR ANY LOSS, INJURY OR DAMAGE TO PERSONS OR PROPERTY, NOR FOR DAMAGES OF ANY KIND RESULTING FROM FAILURE OR DEFECTIVE OPERATION OF ANY MATERIALS OR EQUIPMENT FURNISHED HEREUNDER.





KNIGHT GLOBAL

2705 Commerce Parkway

Auburn Hills, MI 48326

Phone 248-377-4950 | Fax 248-377-2135

For additional copies/literature contact: sales@knightglobal.com

For service related requests contact: service@knightglobal.com

www.knightglobal.com

Printed on February 2019